

EX LIBRIS

ENGINEERING LIBRARY



B. Rabus.

THE THEORY OF HEAT ENGINES

ELEMENTARY APPLIED MECHANICS

BY

ARTHUR MORLEY, M.Sc., M.I.MECH.E.

AND

WILLIAM INCHLEY, B.Sc., A.M.I.MECH.E.

With 285 Diagrams, numerous Examples and Answers.

Crown 8vo, 3s. net.

LABORATORY INSTRUCTION SHEETS
IN ELEMENTARY APPLIED
MECHANICS

BY

ARTHUR MORLEY, M.Sc., M.I.MECH.E.

AND

WILLIAM INCHLEY, B.Sc., A.M.I.MECH.E.

8vo, 1s. 3d. net.

LONGMANS, GREEN & CO.

LONDON, NEW YORK, BOMBAY, AND CALCUTTA.

THE THEORY OF HEAT ENGINES

BY

WILLIAM INCHLEY

B.Sc., A.M.I.MECH.E.

LECTURER IN ENGINEERING IN UNIVERSITY COLLEGE, NOTTINGHAM



WITH 246 DIAGRAMS AND NUMEROUS EXAMPLES

LONGMANS, GREEN, AND CO.

39, PATERNOSTER ROW, LONDON

NEW YORK, BOMBAY, AND CALCUTTA

1913

All rights reserved

TJ265
I6
cp. 2

Engineering
Library

TO VIND
ANNO 1800

ENGINEERING LIBRARY

PREFACE

THIS book has been written mainly for engineering students, and covers the ground required for University and similar examinations in the theory of heat engines. It will also be found suitable for students reading for the examinations of the Institution of Civil Engineers, the Institution of Mechanical Engineers, the City and Guilds of London Institute, and the Board of Education, and should prove useful to the engineer who desires a thorough knowledge of the theory of the subject.

The Author feels that no apology is necessary for adding yet another book on this subject because, although many excellent books exist which deal solely with one or two special branches of the subject, there are very few which deal with the subject as a whole. An attempt has here been made to give in a complete and concise form the thermodynamical and mechanical *principles* of the subject; to that end all purely descriptive matter has been designedly omitted.

Many numerical examples are fully worked out in the text, and the student is urged to read all of these, and to work out for himself the examples at the ends of the chapters in order to obtain a thorough knowledge of the subject. Those marked (L.U.) are taken from various London University papers for the B.Sc. (Engineering) examination.

Many important researches in the subject have been noticed, references to which are freely given. In particular, the *Proceedings* of the Institution of Mechanical Engineers, the Institution of Civil Engineers, and the Reports of the Gaseous Explosions Committee of the British Association have, with permission, been freely drawn upon for this purpose.

The Author's thanks are due to many friends for hints and suggestions, particularly to Professor A. Morley, M.Sc., and Professor W. Robinson, M.E., and also to Mr. R. H. King, B.Sc., Mr. J. S. Robinson, B.Sc., and Mr. T. P. G. Stone, who have so kindly checked many of the numerical examples. It is too much to hope that, with so many numerical examples, this edition will be free from errors; any intimation of these or suggestions for future consideration will be cordially appreciated.

W. INCHLEY.

UNIVERSITY COLLEGE,
NOTTINGHAM,
September, 1913.

969388

CONTENTS

CHAPTER I

THERMODYNAMICS AND PROPERTIES OF GASES

	PAGE
First law of thermodynamics—Laws of permanent gases—Work done during expansion—Adiabatic expansion and compression—Relations between p , v , and T —Rate of heat reception—Entropy	1-22

CHAPTER II

HOT-AIR ENGINES

Classification—Graphic representation of work done during change in volume—Cycles of operation—Carnot's cycle—Carnot's principle—Conditions for maximum efficiency—Second law of thermodynamics—Stirling's engine—Ericsson's engine—Joule's engine	23-39
--	-------

CHAPTER III

PROPERTIES OF STEAM

Generation of steam under constant pressure—Relations between p , v , and t —Total heat—External work done—Internal energy—Superheated steam—Throttling or wire-drawing—Measurement of dryness of steam—Theory of throttling calorimeter—Entropy of steam—Calculation of dryness fraction after expansion—Mollier diagram—Total heat-pressure diagram	40-68
---	-------

CHAPTER IV

THEORY OF THE STEAM ENGINE

Work done during adiabatic expansion of steam—Perfect steam engine working on Carnot's cycle—Non-expansive engine—Rankine cycle— $T\phi$ diagram for Rankine cycle—Effect of using superheated steam—Engine in which the steam is kept dry and saturated during expansion—The regenerative steam engine—Effect of clearance on mean effective pressure—Binary vapour engine	69-102
---	--------

CHAPTER V

THEORY OF THE STEAM ENGINE (*continued*)

Actual indicator diagram—Wire-drawing, clearance and cushioning—Initial condensation and re-evaporation—Temperature range of cylinder walls—Indicated weight of steam—Saturation curve—Missing quantity—Methods of drawing $T\phi$ diagram from $p\upsilon$ diagram—Valve leakage—Most economical ratio of expansion—Steam jacket—Effect of superheating—Diagram factors—Steam consumption, the Willans Law	103-137
---	---------

CHAPTER VI

COMPOUND EXPANSION

	PAGE
Advantages—Compound expansion with and without receiver—Ratio of cylinder volumes—Effect of varying cut-off in high-pressure cylinder—Effect of throttling at admission to high-pressure cylinder—Effect of varying cut-off in low-pressure cylinder—Initial loads—Cylinder dimensions—Combination of indicator diagrams	138-152

CHAPTER VII

MECHANICAL REFRIGERATION

Types of mechanical refrigerating machines—Coefficient of performance—The cold air machine—Reversed Joule engine or Bell-Coleman machine—Warming machine—Vapour compression machines—Choice of a refrigerating agent .	153-170
--	---------

CHAPTER VIII

FLOW OF STEAM THROUGH ORIFICES AND NOZZLES

Adiabatic flow through an orifice—Weight of steam discharged—Flow of superheated steam—Flow through nozzles—Design of nozzles—Use of Mollier diagram—Effect of friction—Theory of injectors—Types of injectors . .	171-185
--	---------

CHAPTER IX

THEORY OF THE STEAM TURBINE

Function of a turbine—Impulse and reaction—Single-stage turbines—Multi-stage turbines—Turbines with one or more stages, each compounded for velocity—Multi-stage reaction turbines—The Parsons turbine—Losses in steam turbines—Effect of pressure, superheat and vacuum on efficiency—Exhaust steam turbines—Governing	186-214
---	---------

CHAPTER X

THEORY OF AIR COMPRESSORS AND MOTORS

Transmission of power by compressed air—Methods of reducing losses—Simple, two-stage, and three-stage air compressors—Effect of clearance—Simple, two-stage, and three-stage air motors—Efficiency of compressors and motors .	215-232
--	---------

CHAPTER XI

COMBUSTION

Combustion of hydrogen, carbon and sulphur—Minimum amount of air required for the complete combustion of 1 pound of solid or liquid fuel, or 1 cubic foot of gaseous fuel—Calculation of quantity of air supplied from the analysis of the flue or exhaust gases—Calculation of mean specific heat—Heat carried away by products of combustion and excess air—Calorific value of solid, liquid, and gaseous fuels—Boiler draught—Theory of producer gas	233-256
---	---------

CHAPTER XII

HEAT TRANSMISSION

	PAGE
Transmission through flat plates—Efficiency of heating surface—Transmission through walls of a thick tube—Effect of high gas speeds—Estimation of the temperature of the gases leaving a boiler—The most efficient rate of combustion—Heat transmission through condenser tubes	257-270

CHAPTER XIII

THEORY OF THE GAS ENGINE

General considerations—Constant volume and constant pressure, four-stroke and two-stroke cycles—Atkinson cycle—Otto cycle—After burning—Effect of strength of mixture—Scavenging—Ignition—Governing—Study of the indicator diagram—Rate of heat reception and rejection from $p\upsilon$ diagrams— $T\phi$ diagram for ideal Otto cycle—Methods of drawing $T\phi$ diagram from $p\upsilon$ diagram—Losses in gas engines—Standard cycle for internal combustion engines—Heat transmission through cylinder walls	271-311
---	---------

CHAPTER XIV

THEORY OF THE INTERNAL COMBUSTION ENGINE
ASSUMING THE SPECIFIC HEAT A LINEAR FUNCTION
OF THE TEMPERATURE

Explosion at constant volume—Internal energy of gases at high temperatures—Measurement of internal energy and specific heat at high temperatures—Rate of heat reception with variable specific heat—Adiabatic expansion with variable specific heat—Reduction of efficiency when the working fluid is replaced by one of greater specific heat—Calculation of ideal efficiency	312-330
--	---------

CHAPTER XV

THEORY OF THE OIL ENGINE

The Diesel engine—Hornsby engine—Other types of heavy oil engines—Petrol engines	331-338
--	---------

CHAPTER XVI

TESTING OF INTERNAL COMBUSTION ENGINES

Commercial tests—Scientific tests—Indicated and brake horse-power—Fuel consumption—Method of drawing up heat account and balance	339-353
--	---------

CHAPTER XVII

STEAM ENGINE AND BOILER TRIALS

Commercial tests—Scientific tests—Indicated and brake horse-power—Steam consumption—Condition of steam at engine stop valve—Method of drawing up heat account and balance—Steam boiler trials—Fuel consumption and calorific value—Rate of water evaporation—Temperature and analysis of flue gases—Efficiency and heat account of a boiler	354-369
---	---------

CHAPTER XVIII

VALVE DIAGRAMS AND VALVE GEARS

	PAGE
Slide valves—Piston displacement curve—Rectangular valve diagram—Reuleaux, Zeuner, Oval and Bilgram valve diagrams—Choice of a valve diagram—Analytical solution—Earliest cut-off possible with simple eccentric valve gear—Meyer expansion valve gear—Link motions—Stephenson, Gooch, and Allan link motions—Hackworth's radial valve gear—Marshall's valve gear—Joy's valve gear	370-409

CHAPTER XIX

TWISTING MOMENT DIAGRAMS

Twisting moment for any crank angle—Inertia of reciprocating parts—Method of drawing twisting moment diagram—Inertia of the connecting-rod—Comparison between exact and approximate effects—Kinetic energy of the connecting-rod—Graphical method for finding twisting moment exerted by the connecting-rod—Function of the fly-wheel—Cyclic variation of speed	410-433
---	---------

CHAPTER XX

BALANCING

Centrifugal force—Dynamical load on a shaft—Method of balancing any number of rotating weights in one plane—Method of balancing any number of rotating weights in more than one plane—Primary balancing—Balancing of locomotives—Secondary balancing	434-451
--	---------

CHAPTER XXI

GOVERNORS

Function of the governor—Watt and Porter governors—Modified Proell governor—Stability and sensitiveness—Hunting—Spring-loaded governors, Hartnell, Hartung, Proell—Curves of controlling force	452-472
--	---------

ANSWERS TO EXAMPLES	473-479
STEAM TABLES	480-481
TABLE OF GLAISHER'S FACTOR	482
MATHEMATICAL TABLES	483-487
INDEX	489

INTRODUCTION

UNITS

SOME of the information given in this introduction will be known to all readers, while the whole of it may be already known to others; it is placed here for convenient reference, and on beginning the study of the Theory of Heat Engines, the student will do well to be thoroughly conversant with the various units used in both the British and the Metric systems.

Units of Work.—The British engineer's unit of work is the foot-pound, being the amount of work done when a force of one pound weight acts through a distance of one foot in its own direction. The unit of work in the metric system is the work done when a force of one kilogramme acts through a distance of one metre; it is called the kilogramme-metre.

Units of Heat.—The *British thermal unit* (B.Th.U.) is the quantity of heat required to raise the temperature of one pound of water 1° F. It is numerically equal to about 778 foot-pounds. Another thermal unit which finds increasing favour with British engineers is the *Centigrade heat unit* (C.H.U.), being the quantity of heat required to raise the temperature of one pound of water 1° C.; it is equal to 778×1.8 or 1400 foot-pounds.

Since the specific heat of water is not quite constant and equal to unity, it follows that the quantity of heat required to raise the temperature of one pound of water 1° F. or 1° C. is not the same at high as at low temperatures; but the difference is so small that in practical calculations it may safely be neglected.

Calorie.—The *gramme-calorie* is the quantity of heat required to raise the temperature of one gramme of water 1° C. The *kilo-calorie* is the quantity of heat required to raise the temperature of one kilogramme of water 1° C.

252 gramme-calories are equivalent to one B.Th.U., and one kilo-calorie is equivalent to 3.96 B.Th.U.

Power.—The British engineer's unit of power is the *horse-power* (usually written H.P.), being the power expended when working at the rate of 550 foot-pounds per second, or 33,000 foot-pounds per minute.

The *French horse-power* (*force de cheval*) is the power expended when working at the rate of 75 kilogramme-metres per second. The electrical engineer's unit of power is the *watt*, being the rate of working when one *ampère* flows under a pressure of one *volt*, *i.e.* when work is being done at the rate of one *joule* per second. One British horse-power is equal to 746 watts.

Kilowatt.—The watt is an inconveniently small unit for practical purposes, hence the electrical engineer usually estimates power in *kilowatts*, one kilowatt being equal to 1000 watts.

Board of Trade Unit.—The Board of Trade unit of electric supply is *one kilowatt-hour*, being the quantity of work done in one hour when working at the rate of one kilowatt, or one thousand joules per second.

Specific Heat.—The usual definition of specific heat may be expressed as the ratio—

$$\frac{\text{Quantity of heat required to raise the temp. of unit mass of a substance } 1^{\circ}}{\text{Quantity of heat required to raise the temp. of unit mass of water } 1^{\circ}}$$

As defined above, the specific heat of a substance is a pure number, and it is immaterial in what units the quantity of heat is expressed. The specific heat of a substance is also frequently expressed as the number of B.Th.U., or foot-pounds, required to raise the temperature of one pound of the substance 1° F.

Specific Heat of Gases.—The specific heat of a gas is not a constant quantity (see Chap. XIV.); it varies with the temperature. The results of most experiments on the energy of gases have been expressed in the form of tables of formulæ giving the specific heat (referred to unit mass of the gas as above) in terms of the temperature. It would appear preferable for most purposes to exhibit them in terms of the internal energy per unit of volume. This is the form most convenient for purposes of thermodynamic calculations, and it has the further advantage that it expresses the actual quantity measured; and in most cases the lower limit of temperature is near that of the room. The rate of change with temperature of the energy so determined is sometimes called the “true” or “instantaneous” specific heat, and sometimes the “thermal capacity” of the gas. The “Gaseous Explosions” Committee of the British Association¹ suggest that this quantity should be called the “volumetric heat,” which, if adopted, should include in its significance that the measurement to which it relates should be made at constant volume and refer to unit volume of the gas. The term “specific heat” could then be restricted to its usual meaning, which refers to unit mass of the substance. They further recommend that the *volumetric heat* be referred to the gramme-molecule under standard conditions, which is nearly the same for all gases, namely 22.25 litres, and that the zero of temperature from which energy is reckoned be 100° C. in order that steam may be included on the same basis as other gases.

The volumetric heat of a gas may also be expressed in foot-pounds per cubic foot by multiplying calories per gramme-molecule by 3.96, since

One calorie per gramme-molecule = 3.96 foot-pounds per cubic foot.

¹ See the First Report of this Committee, Section G, Dublin, 1908.

THE THEORY OF HEAT ENGINES

CHAPTER I

THERMODYNAMICS AND PROPERTIES OF GASES

1. The First Law of Thermodynamics. Heat and mechanical energy are mutually convertible, and Joule's equivalent is the rate of exchange.—The value of this equivalent (usually denoted by the letter J) is 778 foot-pounds are equivalent to one British thermal unit, or 1400 foot-pounds are equal to one Centigrade heat unit.¹ The function of a heat engine is to convert *heat energy* into *mechanical energy*, which operation is much more difficult to perform than to convert mechanical energy into heat energy. If a heat engine converted all the heat energy supplied to it into mechanical energy, it would convert H units of heat into JH units of mechanical energy, where J represents Joule's equivalent. Hence if W represents the number of units of work done we may write

$$W = JH$$

No engine, however, can convert all the heat it receives into work, as will be seen later, the maximum efficiency (Art. 51) ever reached being certainly not much greater than 45 per cent., the actual efficiency of the commercial engine being considerably less (see p. 346).

The Working Fluid.—In all heat engines the working fluid is either a gas or a vapour; when a liquid is converted into the gaseous state it becomes a vapour, and, as such, possesses properties similar to those of a gas. The higher the temperature to which a vapour is heated the more closely does it approximate to a gas; in fact, all gases are merely vapours at temperatures far above the boiling-point of the corresponding liquid.

All vapours at ordinary temperatures can be condensed or liquefied by the application of pressure at constant temperature, but experiment shows that *if a gas is above a certain temperature, it cannot be liquefied by pressure alone.* This temperature, for any particular gas, is called the critical temperature of that gas. Hence, unless a gas is first cooled *below its critical temperature it cannot be liquefied by pressure alone.* The critical temperatures of oxygen, hydrogen, nitrogen, air, etc., are so very low, however, that at the working temperatures used in heat engines these gases may be considered as permanent gases.

2. The First and Second Laws of Permanent Gases.—The first law (*Boyle's Law*) states that in a perfect gas the absolute pressure is

¹ See Robinson's "Gas and Petroleum Engines," or any text-book on physics.

inversely proportional to the volume when the temperature remains constant. If p denotes the pressure and v the volume, we may write

$$p \propto \frac{1}{v}$$

or

$$pv = \text{a constant.}$$

The second law (*Law of Charles*) says that under constant pressure, equal volumes of different gases expand equally for the same increment in temperature; also, if a gas be heated under constant volume, equal increments of its pressure correspond to equal increments of temperature.

For example—492 cubic feet of gas at 32° F. become 491 cubic feet at 31° F., 460 cubic feet at 0° F., and finally, if it follows this law, the gas will have no volume at -460° F. As a matter of fact, any actual gas would change its physical state before reaching so low a temperature.

3. Absolute Temperature.—The absolute temperature of a substance is its temperature reckoned from absolute zero.

If t = the temperature on the ordinary thermometer scale and T = the absolute temperature, then—

$$\begin{aligned} T &= t + 460 \text{ on the Fahrenheit scale,} \\ \text{and } T &= t + 273 \text{ on the Centigrade scale.} \end{aligned}$$

The absolute zero of temperature as obtained by the above reasoning (-460° F. or -273° C.) corresponds very nearly to the absolute zero obtained from the purely thermodynamic considerations discussed in Art. 4, and the above values will be taken in making calculations which involve the absolute temperature.

4. Connection between the Pressure, Volume, and Temperature of a Gas.—Boyle's Law states that $p \propto \frac{1}{v}$ when the temperature remains constant; Charles' Law states that $p \propto T$ when the volume remains constant. Combining the two laws, we have for a given weight of gas

$$pv \propto T \text{ or } pv = RT \dots \dots (1)$$

where p = absolute pressure in pounds per square foot.

v = volume in cubic feet.

T = absolute temperature (Fahrenheit or Centigrade).

R = a constant depending on whether T is expressed on the Fahrenheit or on the Centigrade scale.

For dry air the numerical value of the constant R is 53.18 when T is measured on the Fahrenheit scale; it may be obtained as follows:—

Consider one pound of air at normal temperature and pressure (N.T.P.): under these conditions the weight of one cubic foot of air is known to be 0.0807 pound, hence the volume of one pound is $\frac{1}{0.0807}$ or 12.391 cubic feet.

Standard atmospheric pressure is 14.7×14.4 or 2116 pounds per square foot, and the normal temperature is 32° F. or 492° absolute, hence

$$\begin{aligned} R &= \frac{pv}{T} \\ &= \frac{2116 \times 12.391}{492} \\ &= 53.18 \text{ foot-pounds per pound of air.} \end{aligned}$$

5. **The Third Law of Permanent Gases:** The specific heat at constant pressure is constant for any gas.—Let C_p = specific heat at constant pressure, and C_v the specific heat at constant volume.

Now at *constant volume* the gas does no external work when heated, hence, all the heat supplied is utilised in increasing its stock of internal energy; when heated at *constant pressure* the gas expands and does external work equal to the pressure multiplied by the change in volume.

Suppose 1 pound of gas to be heated at *constant pressure* p from absolute temperature T_1 to absolute temperature T_2 , and let v_1 be the volume of the gas at temperature T_1 , and v_2 the volume at temperature T_2 , then—

$$\begin{aligned} \text{Heat taken in by the gas} &= C_p(T_2 - T_1) \text{ and} \\ \text{Work done by the gas} &= p(v_2 - v_1) \\ &= R(T_2 - T_1) \text{ from (1) Art. 4} \end{aligned}$$

Also

$$\begin{aligned} \text{Increase in internal energy} &= \text{heat taken in} - \text{work done} \\ &= C_p(T_2 - T_1) - R(T_2 - T_1) \\ &= (C_p - R)(T_2 - T_1) \dots (1) \end{aligned}$$

6. **The Fourth Law of Permanent Gases:** When a perfect gas expands without doing external work, and without taking in or giving out heat (and therefore without changing its stock of internal energy), its temperature does not change.—The actual gases met with in practice are not perfect, and for all real gases this law is not perfectly true; for instance, Dr. Joule and Lord Kelvin found that air in expanding freely through a porous plug without doing work became cooled $\frac{1}{4}^\circ$ C. for each atmosphere fall in pressure. From this law we see that whatever may be the change in the pressure and volume of a *perfect* gas when it expands under the above conditions, its store of internal energy remains unaltered, and hence the internal energy of a perfect gas depends only on its temperature.

Suppose one pound of a perfect gas to be heated at *constant volume* from absolute temperature T_1 to absolute temperature T_2 . Then—

$$\begin{aligned} \text{Heat taken in} &= \text{work done} + \text{increase in internal energy} \\ C_v(T_2 - T_1) &= 0 + \text{increase in internal energy} \\ \text{i.e. increase in internal energy} &= C_v(T_2 - T_1) \dots (1) \end{aligned}$$

Now in Art. 5 we saw that the increase in internal energy was equal to $(C_p - R)(T_2 - T_1)$, hence we may say that the expression $C_v(T_2 - T_1)$ represents the increase in internal energy, no matter how the pressure and volume may change during the process.

7. **Relation between the Specific Heats C_p and C_v .**—From Art. 5, the increase in internal energy of one pound of perfect gas when heated at constant pressure from T_1 to T_2 is

$$(C_p - R)(T_2 - T_1)$$

From Art. 6, the increase in internal energy of one pound of perfect gas when heated at constant volume is

$$C_v(T_2 - T_1)$$

Equating these quantities we have—

$$(C_p - R)(T_2 - T_1) = C_v(T_2 - T_1)$$

$$\frac{C_p - R}{C_p} = \frac{C_v}{C_p}$$

which may be written

$$C_p - C_v = R \dots \dots \dots (1)$$

or the difference between the specific heats is constant, and for dry air is equal to 53·18 foot-pounds per pound of air.

Equation (1) may also be written

$$\frac{C_p}{C_v} - 1 = \frac{R}{C_v}$$

The ratio $\frac{C_p}{C_v}$ is very important, and is usually denoted by γ , hence

$$\gamma - 1 = \frac{R}{C_v}$$

or

$$C_v = \frac{R}{\gamma - 1} \dots \dots \dots (2)$$

For dry air Regnault found $C_p = 0.2375$ B.Th.U. per pound, which is equal to 0.2375×778 or 184·8 foot-pounds per pound. The same authority found $C_v = 0.1691$ B.Th.U. per pound, which is equivalent to 0.1691×778 or 131·6 foot-pounds per pound, hence

$$\gamma \text{ or } \frac{C_p}{C_v} = \frac{0.2375}{0.1691} \quad \text{or} \quad \frac{184.8}{131.6} = 1.404$$

the value of γ is not a constant quantity, however, because the specific heat at constant volume (C_v) varies with the temperature (see Chap. XIV.).

8. Work done by a Gas expanding according to Boyle's Law. Isothermal or Hyperbolic Expansion.—Suppose the expansion takes place from the initial state p_1, v_1 , and T_1 , to the final state p_2, v_2 , and T_2 .

The law of the expansion curve is $p v = a \text{ constant} = k$, say; for a small change in volume δv during which the average pressure is \bar{p} (Fig. 1) the work done

$$\delta W = \bar{p} \times \delta v$$

Let W denote the work done during the expansion, then

$$W = \int_{v_1}^{v_2} \bar{p} \, dv.$$

Since

$$p v = k = RT$$

$$\bar{p} = \frac{k}{\bar{v}}.$$

$$\therefore W = \int_{v_1}^{v_2} \frac{k}{v} \, dv = k [\log_e v]_{v_1}^{v_2} = k \log_e \frac{v_2}{v_1}$$

or

$$W = p_1 v_1 \log_e \frac{v_2}{v_1} \quad \text{or} \quad RT \log_e \frac{v_2}{v_1} \dots \dots \dots (1)$$

which may be written,

$$W = p_1 v_1 \log_e r \dots \dots \dots (2)$$

where r is the ratio of expansion, *i.e.* $\frac{\text{final volume}}{\text{initial volume}}$.

9. **Work done by a Gas expanding according to the Law $p v^n = \text{a Constant}$.**—As in Art. 8, let the expansion take place from the state $p_1, v_1,$ and $T_1,$ to the state $p_2, v_2,$ and $T_2,$ then

$$W = \int_{v_1}^{v_2} p \, dv$$

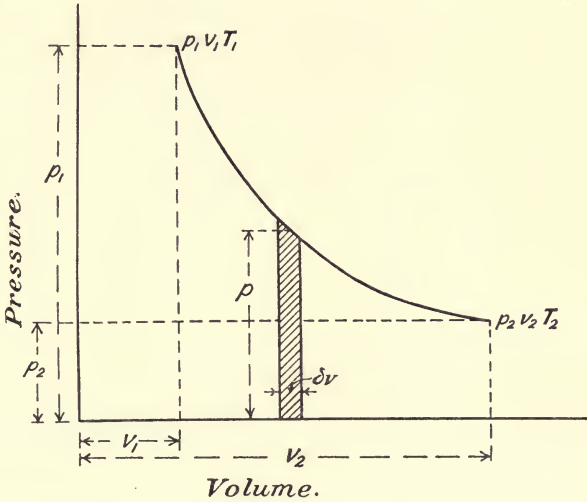

FIG. 1.

The law of the expansion curve is $p v^n = \text{a constant} = k,$ say,

$$\therefore p = \frac{k}{v^n}$$

$$\begin{aligned} \therefore W &= \int_{v_1}^{v_2} \frac{k}{v^n} \, dv \\ &= k \left[\frac{1}{1-n} \cdot v^{1-n} \right]_{v_1}^{v_2} \\ &= \frac{k}{1-n} \{ v_2^{1-n} - v_1^{1-n} \} \\ &= \frac{p_1 v_1^n}{1-n} \{ v_2^{1-n} - v_1^{1-n} \} \dots \dots \dots (1) \end{aligned}$$

and since $p_1 v_1^n = p_2 v_2^n,$ equation (1) becomes

$$W = \frac{p_1 v_1 - p_2 v_2}{n - 1} \dots \dots \dots (2)$$

Also for a perfect gas $p v = RT,$ and (2) may be written

$$W = \frac{RT_1 - RT_2}{n - 1} \quad \text{or} \quad \frac{R(T_1 - T_2)}{n - 1} \dots \dots \dots (3)$$

This expression for work done may be put in several forms, as follows:—

Since $W = \frac{p_1 v_1^n}{1-n} \{v_2^{1-n} - v_1^{1-n}\}$ we may write

$$\begin{aligned} W &= \frac{p_1}{1-n} \{v_1^n \times v_2^{1-n} - v_1\} \\ &= \frac{p_1 v_1}{1-n} \{v_1^{n-1} \times v_2^{1-n} - 1\} \\ &= \frac{p_1 v_1}{1-n} \left\{ \left(\frac{v_1}{v_2} \right)^{n-1} - 1 \right\} \end{aligned}$$

or

$$W = \frac{p_1 v_1}{n-1} \left\{ 1 - \left(\frac{v_1}{v_2} \right)^{n-1} \right\} \dots \dots \dots (4)$$

Again,

$$\begin{aligned} p_1 v_1^n &= p_2 v_2^n \\ \left(\frac{v_1}{v_2} \right)^n &= \frac{p_2}{p_1} \dots \dots \dots (5) \end{aligned}$$

Substituting (5) in (4), we have—

$$W = \frac{p_1 v_1}{n-1} \left\{ 1 - \left(\frac{p_2}{p_1} \right)^{\frac{n-1}{n}} \right\} \dots \dots \dots (6)$$

If all pressures are measured in pounds per square foot, and all volumes in cubic feet, the work done as calculated from either (2), (4), or (6), will be in foot-pounds.

If all pressures are measured in kilograms per square metre, and all volumes in cubic metres, the work done as calculated from the above formulæ will be in kilogram-metres.

For most purposes, particularly when under examination, the student is advised to remember and use the simple form $\frac{p_1 v_1 - p_2 v_2}{n-1}$.

10. Adiabatic Expansion and Compression.—When a gas expands without gaining or losing heat, and does an amount of work equal to the difference between its initial and final internal energy, the expansion is said to be adiabatic; conversely, if a gas is compressed without either heat being supplied to it or taken away from it, its change of internal energy being equal to the work done on it, the compression is said to be adiabatic. The value of “*n*” in the general $p v^n = \text{a constant}$ may be found as follows:—

When heat is supplied to a gas we have the fundamental relation discovered by Dr. Joule

heat supplied = work done + increase in internal energy

Let δH denote a small quantity of heat supplied, and δT and δv the resulting small increments of temperature and volume, then

$$\delta H = p \delta v + C_v \delta T$$

If the expansion takes place without gain or loss of heat as in adiabatic operations, $\delta H = 0$, hence

$$\begin{aligned} C_v \delta T + p \delta v &= 0 \\ \frac{\delta T}{\delta v} &= - \frac{p}{C_v} \end{aligned}$$

or

hence in the limit :

$$\frac{dT}{dv} = -\frac{p}{C_v} \dots \dots \dots (1)$$

Now for a perfect gas $pv = RT = (C_p - C_v)T$ (Art. 7).
Differentiating we have—

$$\frac{dT}{dv} (C_p - C_v) = p + v \frac{dp}{dv} \dots \dots \dots (2)$$

Substituting the value of $\frac{dT}{dv}$ from (1) in (2) gives

$$-\frac{p}{C_v} (C_p - C_v) = p + v \frac{dp}{dv}$$

$$-p \frac{C_p}{C_v} + p = p + v \frac{dp}{dv}$$

$$-p\gamma = v \frac{dp}{dv}$$

or
$$\frac{dp}{p} = -\gamma \cdot \frac{dv}{v}$$

Integrating we have

$$\log p = -\gamma \log v + \text{a constant}$$

or
$$\log p + \gamma \log v = \text{constant}$$

or
$$pv^\gamma = \text{constant.}$$

Hence the law of an adiabatic expansion or compression curve is $pv^\gamma = \text{constant}$, where $\gamma = \frac{C_p}{C_v}$.

Alternative Method.—This result may also be found as follows :—
From (3) Art. 9,

$$W = \frac{R(T_1 - T_2)}{n - 1}$$

Now if the gas changes in temperature from T_1 to T_2 its internal energy is diminished by the amount

$$C_v(T_1 - T_2) \text{ from Art. 6,}$$

or
$$\frac{R}{\gamma - 1} (T_1 - T_2) \text{ since } C_v = \frac{R}{\gamma - 1} \text{ (Art. 7, equation (2))}$$

Hence equating the loss of internal energy to the work done, the condition for adiabatic expansion is secured when

$$\frac{R}{\gamma - 1} (T_1 - T_2) = \frac{R}{n - 1} (T_1 - T_2)$$

that is when $n = \gamma$.

Hence the expansion or compression will be adiabatic when

$$pv^\gamma = \text{constant.}$$

11. Relations between Pressure, Volume and Temperature during the Expansion or Compression of a Gas according to the Law $p v^n = \text{Constant}$.

Now $p_1 v_1^n = p_2 v_2^n = \text{constant} \dots \dots \dots (1)$

and since for a perfect gas $p v = R T$ or $\frac{p v}{T} = R$ (a constant)

$$\frac{p_1 v_1}{T_1} = \frac{p_2 v_2}{T_2}$$

$$\frac{p_2 v_2}{p_1 v_1} = \frac{T_2}{T_1} \dots \dots \dots (2)$$

From (1) $\frac{p_2}{p_1} = \left(\frac{v_1}{v_2}\right)^n \dots \dots \dots (3)$

Substituting (3) in (2) gives

$$\frac{T_2}{T_1} = \left(\frac{v_1}{v_2}\right)^n \times \frac{v_2}{v_1} = \left(\frac{v_1}{v_2}\right)^{n-1} \dots \dots \dots (4)$$

Again, from (1) $\frac{v_2}{v_1} = \left(\frac{p_1}{p_2}\right)^{\frac{1}{n}} \dots \dots \dots (5)$

Substituting (5) in (2) gives

$$\frac{T_2}{T_1} = \frac{p_2}{p_1} \times \left(\frac{p_1}{p_2}\right)^{\frac{1}{n}} = \left(\frac{p_2}{p_1}\right)^{\frac{n-1}{n}} \dots \dots \dots (6)$$

Hence we may write the expression for work done, equation 6, Art. 9 :

$$W = \frac{p_1 v_1}{n-1} \left\{ 1 - \frac{T_2}{T_1} \right\} \dots \dots \dots (7)$$

12. Collection of the Formulæ proved above,

$$C_v = C_p - R = \frac{R}{\gamma - 1} \dots \dots \dots (1)$$

For isothermal or hyperbolic expansion,

$$W = p_1 v_1 \log_e r \dots \dots \dots (2)$$

For adiabatic expansion,

$$W = \frac{p_1 v_1 - p_2 v_2}{\gamma - 1} \dots \dots \dots (3)$$

$$= \frac{p_1 v_1}{\gamma - 1} \left\{ 1 - \left(\frac{v_1}{v_2}\right)^{\gamma-1} \right\} \dots \dots \dots (4)$$

$$= \frac{p_1 v_1}{\gamma - 1} \left\{ 1 - \left(\frac{p_2}{p_1}\right)^{\frac{\gamma-1}{\gamma}} \right\} \dots \dots \dots (5)$$

$$= \frac{p_1 v_1}{\gamma - 1} \left\{ 1 - \frac{T_2}{T_1} \right\} \dots \dots \dots (6)$$

For adiabatic expansion,

$$\frac{p_2}{p_1} = \left(\frac{v_1}{v_2}\right)^\gamma \dots \dots \dots (7)$$

$$\frac{v_2}{v_1} = \left(\frac{p_1}{p_2}\right)^{\frac{1}{\gamma}} \dots \dots \dots (8)$$

$$\frac{T_2}{T_1} = \left(\frac{v_1}{v_2}\right)^{\gamma-1} \text{ or } \left(\frac{p_2}{p_1}\right)^{\frac{\gamma-1}{\gamma}} \dots \dots \dots (9)$$

If the expansion is not adiabatic but follows the general law $p v^n = a$ constant, the equations (3) to (9) inclusive will hold if n is used instead of γ .

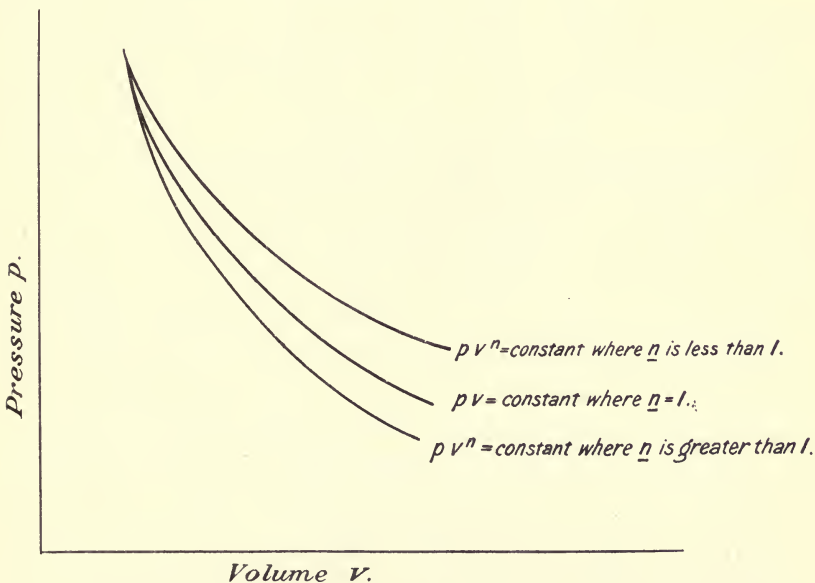

FIG. 2.

13. Effect of “n” on the Slope of the Expansion or Compression Curve.—The slope of the curve is given by $\frac{dp}{dv}$, and since $p v^n = k$,

$$p = \frac{k}{v^n}$$

and

$$\frac{dp}{dv} = -\frac{kn}{v^{n+1}} = -\frac{np}{v}$$

From this expression we see that as “n” increases $\frac{dp}{dv}$ increases also, the effect on the slope of the curve being as shown in Fig. 2.

14. Rate of Heat Reception or Rejection assuming Constant Specific Heats.—Let “ $d p$ ” be an indefinitely small change of pressure accompanying an indefinitely small change in volume “ $d v$.” Then $\frac{d p}{d v}$ is the rate of change of pressure with respect to volume.

Also if “ $d H$ ” be the small quantity of heat given to the gas during the above small changes of pressure and volume, and $d T$ the small change in temperature, $\frac{d H}{d v}$ will represent the rate at which the expanding gas receives heat per unit change in volume.

Now for a perfect gas we have for any kind of expansion

$$p v = R T$$

or

$$T = \frac{p v}{R}$$

Differentiating we get

$$\frac{d T}{d v} = \frac{1}{R} \left(p + v \frac{d p}{d v} \right) \dots \dots \dots (1)$$

But heat supplied = work done + increase in internal energy,

$$d H = p d v + C_v d T$$

and

$$\frac{d H}{d v} = p + C_v \frac{d T}{d v} \dots \dots \dots (2)$$

Substituting in (2) the value $C_v = \frac{R}{\gamma - 1}$, and the value of $\frac{d T}{d v}$ from (1), we have

$$\begin{aligned} \frac{d H}{d v} &= p + \frac{R}{\gamma - 1} \cdot \frac{1}{R} \left(p + v \frac{d p}{d v} \right) \\ &= p + \frac{1}{\gamma - 1} \left(p + v \frac{d p}{d v} \right) \\ &= \frac{1}{\gamma - 1} \left(\gamma p + v \frac{d p}{d v} \right) \dots \dots \dots (3) \end{aligned}$$

If now the expansion takes place according to the general law $p v^n = k$, we have

$$\frac{d p}{d v} = - \frac{k n}{v^{n+1}} \text{ or } k v^{-n} \times - n v^{-1}$$

But

$$k v^{-n} = p$$

Hence

$$\frac{d p}{d v} = - \frac{n p}{v}$$

Substituting this value of $\frac{d p}{d v}$ in (3) we have

$$\frac{d H}{d v} = \frac{1}{\gamma - 1} (\gamma p - n p)$$

or

$$\frac{d H}{d v} = p \cdot \frac{\gamma - n}{\gamma - 1} \dots \dots \dots (4)$$

Thus we see that for an adiabatic expansion or compression in which $n = \gamma$, $\frac{dH}{dv} = 0$. This result is obvious, since heat is neither received nor rejected during any adiabatic operation.

Alternative Proof.—This result may also be obtained in the following manner :—

Let H = the amount of heat supplied or rejected during the operation, and let the change of state be from p_1, v_1, T_1 , to p_2, v_2, T_2 .

Then

$$\begin{aligned} H &= \text{work done} + \text{change in internal energy,} \\ &= \int_{v_1}^{v_2} p dv + C_v(T_2 - T_1) \\ &= \frac{p_1 v_1 - p_2 v_2}{n - 1} - \frac{R}{\gamma - 1} \left(\frac{p_1 v_1}{R} - \frac{p_2 v_2}{R} \right) \\ &= \frac{p_1 v_1 - p_2 v_2}{n - 1} - \frac{p_1 v_1 - p_2 v_2}{\gamma - 1} \\ &= (p_1 v_1 - p_2 v_2) \left(\frac{1}{n - 1} - \frac{1}{\gamma - 1} \right) \\ &= \frac{p_1 v_1 - p_2 v_2}{n - 1} \times \frac{\gamma - n}{\gamma - 1} \end{aligned}$$

or $H = \frac{\gamma - n}{\gamma - 1} \times \text{work done} \dots \dots \dots (5)$

Hence $dH = \frac{\gamma - n}{\gamma - 1} \times v dv$,

or $\frac{dH}{dv} = \frac{\gamma - n}{\gamma - 1} \cdot p$ as before.

Now $\frac{dH}{dv}$ represents the rate of heat reception per unit change in volume, hence the rate of heat reception per *second* will be given by

$$\frac{dH}{dv} \times \text{velocity of piston in feet per second.}$$

If “ n ” is less than “ γ ,” the rate of heat reception $\frac{dH}{dv}$ will be positive; whereas if “ n ” is greater than “ γ ,” the rate of reception $\frac{dH}{dv}$ will be negative. Hence, if the expansion curve is less steep than the adiabatic $p v^\gamma = k$, *i.e.* when “ n ” is less than “ γ ,” the gas is *receiving* heat during the expansion; but if the curve is steeper than the adiabatic, *i.e.* if “ n ” is greater than “ γ ,” the gas is *losing* heat during the expansion.

If the expansion is isothermal ($n = 1$) the heat received is equal to the thermal equivalent of the work done from (5). Similarly, if the gas is compressed isothermally, an amount of heat equal to the work done on the gas must be taken away from the gas. Also, if the gas is being compressed and “ n ” is less than “ γ ,” the rate of heat *rejection* will be positive, *i.e.* heat will be taken from the gas; if, however, “ n ” is greater than “ γ ” the rate of heat *rejection* will be negative, and the gas will be *receiving* heat during the compression.

EXAMPLE 1.—The temperature of 1 pound of air is observed to fall from 600° F. to 300° F. while it expands adiabatically, doing 39,445 foot-pounds of work. Find C_v and C_p .

Since the expansion is adiabatic, no heat is supplied to or taken away from the air during the process. Hence the work done will be equal to the loss of internal energy during the expansion, namely

$$C_v \times (\text{fall in temperature}).$$

Expressing both quantities in heat units we have

$$\text{loss of internal energy} = \text{work done},$$

$$C_v(600 - 300) = \frac{39,445}{778}$$

$$C_v = \frac{39,445}{778 \times 300} = 0.169, \text{ B.Th.U. per pound.}$$

$$\text{Now } \frac{C_p}{C_v} = 1.4 \text{ (Art. 7)}$$

$$\text{hence } C_p = 0.169 \times 1.4 = 0.237 \text{ B.Th.U. per pound.}$$

EXAMPLE 2.—One cubic foot of gas at a pressure of 300 pounds per square inch absolute expands to 60 pounds per square inch absolute, the law of expansion being $p v^{1.2} = \text{constant}$. Find the volume at the end of the expansion, and the work done during expansion.

$$p_1 v_1^{1.2} = p_2 v_2^{1.2}$$

$$v_2^{1.2} = \frac{p_1}{p_2} v_1^{1.2} = \frac{300}{60} \times 1^{1.2} = 5$$

$$1.2 \log v_2 = \log 5$$

from which $v_2 = 3.823$ cubic feet.

$$\begin{aligned} \text{Work done} &= \frac{p_1 v_1 - p_2 v_2}{n - 1} = \frac{144(300 \times 1 - 60 \times 3.823)}{1.2 - 1} \\ &= 50,820 \text{ foot-pounds.} \end{aligned}$$

The work done might also be found without calculating v_2 by using equation (5), Art. 12, *i.e.*

$$\begin{aligned} W &= \frac{p_1 v_1}{n - 1} \left\{ 1 - \left(\frac{p_2}{p_1} \right)^{\frac{n-1}{n}} \right\} \\ &= \frac{300 \times 144 \times 1}{0.2} \left\{ 1 - \left(\frac{1}{5} \right)^{\frac{0.2}{1.2}} \right\} \\ &= 216,000 \left\{ 1 - \left(\frac{1}{5} \right)^{\frac{1}{6}} \right\} \\ &= 50,820 \text{ foot-pounds as before.} \end{aligned}$$

EXAMPLE 3.—One pound of dry air (volume 12.39 cubic feet) at atmospheric pressure requires compressing to a pressure of 200 pounds per square inch absolute: which will be the more economical, to compress isothermally or adiabatically?

(1) *Isothermal compression.*—

$$p_1 v_1 = p_2 v_2 \therefore v_2 = \frac{p_1 v_1}{p_2} = \frac{14.7 \times 12.39}{200} = 0.91 \text{ cubic feet.}$$

$$\begin{aligned} \text{Work done on the gas} &= p_1 v_1 \log_e \left(\frac{v_1}{v_2} \right) \\ &= 144 \times 14.7 \times 12.39 \log_e \frac{12.39}{0.91} \\ &= 144 \times 14.7 \times 12.39 \log_e 13.6 \\ &= 2116 \times 12.39 \times 2.607 \\ &= 68,320 \text{ foot-pounds.} \end{aligned}$$

(2) *Adiabatic compression.*—Using (5), Art. 12,

$$\begin{aligned} W &= \frac{2116 \times 12.39}{1.4 - 1} \left\{ 1 - 13.6^{\frac{2}{7}} \right\} = \frac{2116 \times 12.39}{0.4} \left\{ 1 - 2.108 \right\} \\ &= -72,630 \text{ foot-pounds.} \end{aligned}$$

The negative sign simply means that work is done *on* the gas. Hence, by compressing isothermally we save $72,630 - 68,230 = 4,400$ foot-pounds.

EXAMPLE 4.—Ten cubic feet of air at 90 lbs. per square inch abs. and at 65° F. are expanded to four times the original volume, the law of expansion being $p v^{1.25} = \text{const.}$ Given $C_v = 130.3$ ft.-lbs. per lb., and $C_p = 183.4$ ft.-lbs. per lb.: find—

(1) The temperature of air at the end of expansion.

(2) The work done in ft.-lbs.

(3) The amount of heat which must have been given by, or been rejected to, an external source during the cycle.

$$(1) \quad \frac{T_2}{T_1} = \left(\frac{v_1}{v_2} \right)^{1.25-1} = \left(\frac{1}{4} \right)^{\frac{1}{4}} = \left(\frac{1}{2} \right)^{\frac{1}{2}} = \frac{1}{\sqrt{2}} = 0.707$$

$$\begin{aligned} \therefore T_2 &= 0.707 T_1 = 0.707 (65 + 460) \\ &= 0.707 \times 525 = 371.2^\circ \text{ absolute} \end{aligned}$$

$$\therefore t_2^\circ \text{ F.} = 371.2 - 460 = -88.8^\circ \text{ F.} = \text{temperature of air at the end of expansion.}$$

$$(2) \text{ Now } p_1 v_1^{1.25} = p_2 v_2^{1.25}$$

$$\begin{aligned} \therefore p_2 &= p_1 \times \left(\frac{v_1}{v_2} \right)^{1.25} = 90 \times \left(\frac{1}{4} \right)^{\frac{5}{4}} \\ &= 90 \times (0.707)^5 = 15.84 \text{ lbs. per sq. in.} \end{aligned}$$

$$\begin{aligned} \therefore \text{Work done } W &= \frac{p_1 v_1 - p_2 v_2}{n - 1} \\ &= 144 \cdot \frac{90 \times 10 - 15.84 \times 40}{0.25} \\ &= 576 \times (900 - 633.6) = 576 \times 266.4 = 153,446 \text{ ft.-lbs.} \end{aligned}$$

$$(3) \text{ From (5), Art. 14. Heat given } H = W \cdot \frac{\gamma - n}{\gamma - 1}$$

$$\begin{aligned} &= 153,446 \times \frac{1.4 - 1.25}{1.4 - 1} \\ &= 153,446 \times \frac{3}{8} = 57,542 \text{ ft.-lbs.} \\ &= 73.9 \text{ B.Th.U.} \end{aligned}$$

EXAMPLE 5.—Air is drawn into a cylinder and compressed adiabatically to a pressure of 75 lbs. above its original pressure (15 lbs. per sq. in. abs.), and is then expelled at this pressure into a receiver; its original temperature was 60° F. In the receiver the compressed air cools down to its original temperature, and, in order to maintain a uniform pressure in the receiver, an equal weight of compressed air is constantly drawn off and expanded isothermally in a working cylinder down to 15 lbs. pressure. Calculate (a) the work spent per lb. of air in the compressor; (b) the work done per lb. of air in expanding; (c) the temperature of the air as it enters the receiver.

(a) Now $p_1 v_1^{1.4} = p_2 v_2^{1.4}$ per cubic foot at 60° F.

$$\therefore \left(\frac{v_2}{v_1}\right)^{1.4} = \frac{p_1}{p_2} = \frac{15}{90}$$

$$\therefore 1.4 \log v_2 - 1.4 \log v_1 = \log 15 - \log 90$$

$$\therefore 1.4 \log v_2 = 1.1761 - 1.9542 = -0.7781$$

$$\therefore \log v_2 = -\frac{0.7781}{1.4} = -0.5559 = \bar{1}.4441$$

$$\therefore v_2 = 0.2781 \text{ cubic ft.}$$

$$\begin{aligned} \text{Work done per cycle} &= p_2 v_2 - p_1 v_1 + \frac{p_2 v_2 - p_1 v_1}{1.4 - 1} = 3.5(p_2 v_2 - p_1 v_1) \\ &= 3.5 \times 144(90 \times 0.2781 - 15) \\ &= 3.5 \times 144(25.029 - 15) \\ &= 3.5 \times 144 \times 10.029 = 5065 \text{ ft.-lbs.} \end{aligned}$$

Taking the volume of 1 lb. of air at 60° F. = 13 cubic ft., we have—

$$\text{Work done per lb. of air} = 5065 \times 13 = 65,845 \text{ ft.-lbs.}$$

(b) Work done per cubic foot in expanding

$$= p v \log_e r = p v \log_e \frac{90}{15}$$

$$= 15 \times 144 \times 2.303 \times 0.7782 = 3870 \text{ ft.-lbs.}$$

$$\therefore \text{Work done per lb.} = 3870 \times 13 = 50,310 \text{ ft.-lbs.}$$

$$(c) \quad \frac{T_2}{T_1} = \left(\frac{p_2}{p_1}\right)^{\frac{1.4-1}{1.4}} = \left(\frac{90}{15}\right)^{\frac{2}{7}} = 6^{\frac{2}{7}}$$

$$\text{And } T_1 = 60 + 460 = 520^\circ \text{ absolute}$$

$$\therefore T_2 = 520 \times 6^{\frac{2}{7}}$$

$$\begin{aligned} \log T_2 &= \log 520 + \frac{2}{7} \log 6 = 2.7160 + \frac{2}{7} \times 0.7782 \\ &= 2.7160 + 0.2223 \end{aligned}$$

$$\therefore \log T_2 = 2.9383$$

$$\therefore T_2 = 867.6^\circ \text{ abs.} = 867.6 - 460 = 407.6^\circ \text{ F.}$$

EXAMPLE 6.—12.39 cubic feet of air at atmospheric pressure are compressed to a pressure of 200 pounds per square inch absolute. Find the quantity of heat which must be added to or taken away from the air during the operation (a) when the compression is isothermal; (b) when the compression is according to the law $p v^{1.2} = \text{constant}$.

(a) From Example 3 the work done *on* the gas during compression is equal to 68,320 foot-pounds. Hence the heat taken away from the gas during compression is equal to 68,320 foot-pounds, or

$$\frac{68,320}{778} = 87.8 \text{ B.Th.U.}$$

or
$$\frac{68,320}{1400} = 48.8 \text{ C.H.U.}$$

$$\begin{aligned} (b) \text{ Work done} &= \frac{p_1 v_1}{n-1} \left\{ 1 - \left(\frac{p_2}{v_1} \right)^{\frac{n-1}{n}} \right\} \\ &= \frac{14.7 \times 144 \times 12.39}{1.2-1} \left\{ 1 - \left(\frac{200}{14.7} \right)^{\frac{1.2-1}{1.2}} \right\} \\ &= \frac{2116 \times 12.39}{0.2} \left\{ 1 - (13.6)^{\frac{1}{6}} \right\} \\ &= 131,086 \{ 1 - 1.545 \} \\ &= -71,440 \text{ foot-pounds.} \end{aligned}$$

Hence the work done *on* the gas during the compression is 71,440 foot-pounds.

From (5), Art. 14, the heat taken away from the gas during the compression is

$$H = \frac{\gamma - n}{\gamma - 1} \times \text{work done}$$

$$= \frac{1.4 - 1.2}{1.4 - 1} \times 71,440$$

$$= \frac{0.2}{0.4} \times 71,440$$

$$= 35,720 \text{ foot-pounds}$$

or
$$H = \frac{35,720}{778} = 45.9 \text{ B.Th.U.}$$

or
$$\frac{35,720}{1400} = 25.5 \text{ C.H.U.}$$

15. Entropy; Definition.—The entropy (denoted by ϕ) of a substance is that thermal property of it which remains constant when the substance neither gains nor loses heat from external sources, as in adiabatic operations, and which is increased or reduced when heat is given to or taken from the gas. Consequently adiabatic operations are often called *isentropic*, *i.e.* operations at constant entropy. When a pound of any substance takes in or gives out a quantity of heat H at the *absolute* temperature T , its gain or loss of entropy ϕ is measured by the quantity $\frac{H}{T}$ so that the quantity of heat $H = T \times$ change in entropy, *i.e.*

$$H = T \times \phi.$$

If the temperature is not constant we may define the change of entropy by the general expression $\sum \frac{\delta H}{T}$, each element δH of heat supplied or rejected being divided by the absolute temperature the substance had at

the time. For an adiabatic, $\delta H = 0$, since the change of heat is nothing, *i.e.* the substance expands or is compressed without gain or loss of heat (Art. 10).

Consider the indicator diagram shown in Fig. 3. The area of this diagram represents the work done to some scale. The temperature entropy diagram is shown alongside. During the isothermal expansion DA on the p.v. diagram, the change of entropy is represented by da on the $T\phi$ diagram; during the adiabatic or isentropic expansion AB, the entropy is constant, and is represented by ab ; similarly, during the isothermal compression BC the change of entropy is bc , whilst the adiabatic or isentropic compression CD is represented by cd . The diagram " $dabc$ " is called the "Temperature-Entropy" diagram and corresponds to the indicator or "Pressure-Volume" diagram DABC.

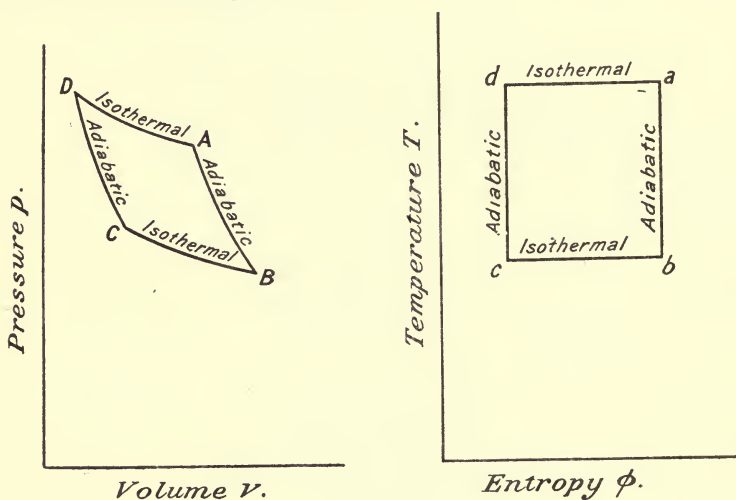

FIG. 3.

Again, when a quantity of heat H passes from one body at absolute temperature T_1 to another body at a lower temperature T_2 , the warm body loses entropy $\frac{H}{T_1}$ and the colder body gains entropy $\frac{H}{T_2}$. Now, since T_2 is less T_1 the gain of entropy of the system as a whole is

$$\frac{H}{T_2} - \frac{H}{T_1} = H \cdot \frac{T_1 - T_2}{T_1 T_2}$$

If one pound of any substance gains heat by the small amount δH the temperature remaining constant at T during this small change, its gain of entropy as we have already seen will be

$$\delta\phi = \frac{\delta H}{T}$$

or in the limit

$$\delta\phi = \frac{dH}{T}$$

If now the pound of substance is raised in temperature from T_2 to T_1 the total gain of entropy will be given by

$$\sum \frac{\delta H}{T} = \sum \frac{C \delta T}{T}$$

where C = specific heat of the substance ;

or
$$\int_{T_2}^{T_1} \frac{C dT}{T} = C \log_{\epsilon} \frac{T_1}{T_2} \dots \dots \dots (1)$$

It should be noted that entropy units are the same whether H and T are *both* measured on the Fahrenheit or on the Centigrade scales.

16. General Expression for the Change of Entropy of a Perfect Gas when passing from the State p_1, v_1, T_1 , to the State p_2, v_2, T_2 .—Since the energy equation for a perfect gas is given by

$$H = C_v (T_1 - T_2) + p (v_2 - v_1) \quad (\text{Art. 10})$$

we have for a small change

$$\delta H = C_v \delta T + p \delta v \dots \dots \dots (1)$$

Dividing both sides of the equation by T we have

$$\frac{\delta H}{T} = C_v \frac{\delta T}{T} + \frac{p}{T} \delta v$$

or in the limit

$$\frac{dH}{T} = C_v \cdot \frac{dT}{T} + \frac{p}{T} dv \dots \dots \dots (2)$$

Now
$$pv = RT \quad \text{or} \quad \frac{p}{T} = \frac{R}{v} \dots \dots \dots (3)$$

Substituting (3) in (2) we have

$$\frac{dH}{T} = C_v \frac{dT}{T} + R \frac{dv}{v}$$

Integrating we have

$$\int_{T_1}^{T_2} \frac{dH}{T} = C_v \int_{T_1}^{T_2} \frac{dT}{T} + R \int_{v_1}^{v_2} \frac{dv}{v}$$

or gain of entropy
$$\phi_2 - \phi_1 = C_v \log_{\epsilon} \frac{T_2}{T_1} + R \log_{\epsilon} \frac{v_2}{v_1} \dots \dots \dots (4)$$

Now $R = C_p - C_v$, hence

$$\phi_2 - \phi_1 = C_v \log_{\epsilon} \frac{T_2}{T_1} + (C_p - C_v) \log_{\epsilon} \frac{v_2}{v_1} \dots \dots \dots (5)$$

$$= C_v \left(\log_{\epsilon} \frac{T_2}{T_1} - \log_{\epsilon} \frac{v_2}{v_1} \right) + C_p \log_{\epsilon} \frac{v_2}{v_1}$$

$$= C_v \log_{\epsilon} \left(\frac{T_2}{T_1} \times \frac{v_1}{v_2} \right) + C_p \log_{\epsilon} \frac{v_2}{v_1} \dots \dots \dots (6)$$

Also since

$$\frac{p_1 v_1}{T_1} = \frac{p_2 v_2}{T_2}$$

$$\frac{p_2}{p_1} = \frac{T_2}{T_1} \times \frac{v_1}{v_2} \dots \dots \dots (7)$$

Substituting (7) in (6) we have

$$\phi_2 - \phi_1 = C_v \log_{\epsilon} \frac{p_2}{p_1} + C_p \log_{\epsilon} \frac{v_2}{v_1} \dots \dots \dots (8)$$

Another expression can be found for the change of entropy as follows:—

Substituting $C_v = C_p - R$ in (4) we have

$$\begin{aligned}\phi_2 - \phi_1 &= (C_p - R) \log_{\epsilon} \frac{T_2}{T_1} + R \log_{\epsilon} \frac{v_2}{v_1} \\ &= C_p \log_{\epsilon} \frac{T_2}{T_1} - R \left(\log_{\epsilon} \frac{T_2}{T_1} - \log_{\epsilon} \frac{v_2}{v_1} \right) \\ &= C_p \log_{\epsilon} \frac{T_2}{T_1} - R \log_{\epsilon} \left(\frac{T_2}{T_1} \times \frac{v_1}{v_2} \right) \\ &= C_p \log_{\epsilon} \frac{T_2}{T_1} - R \log_{\epsilon} \frac{p_2}{p_1} \text{ from (7) (9)}\end{aligned}$$

Hence in calculating the change of entropy of a perfect gas when passing from the state p_1, v_1, T_1 , to the state p_2, v_2, T_2 , we may use either (4), (8), or (9), *i.e.*

$$\left. \begin{aligned}\phi_2 - \phi_1 &= C_v \log_{\epsilon} \frac{T_2}{T_1} + R \log_{\epsilon} \frac{v_2}{v_1} \\ &= C_v \log_{\epsilon} \frac{p_2}{p_1} + C_p \log_{\epsilon} \frac{v_2}{v_1} \\ &= C_p \log_{\epsilon} \frac{T_2}{T_1} - R \log_{\epsilon} \frac{p_2}{p_1}\end{aligned} \right\}$$

If British units are used, R, C_p and C_v should all be expressed either in B.Th.U. or in C.H.U., v_2 and v_1 in cubic feet, p_2 and p_1 in pounds per square foot; the change of entropy will then be measured in "units of entropy." No name has been universally accepted for the unit of entropy, but Professor Perry has proposed to measure entropy in *Ranks*.

In the case of an isothermal change of state from p_1, v_1 , to p_2, v_2 , $T_1 = T_2$, and equation (4) becomes

$$\begin{aligned}\phi_2 - \phi_1 &= C_v \log_{\epsilon} \frac{T_2}{T_1} + R \log_{\epsilon} \frac{v_2}{v_1} \\ &= R \log_{\epsilon} \frac{v_2}{v_1} \quad \text{or} \quad (C_p - C_v) \log_{\epsilon} \frac{v_2}{v_1} . . . (10)\end{aligned}$$

If the change takes place at *constant volume*, $v_2 = v_1$ and (4) becomes

$$\phi_2 - \phi_1 = C_v \log_{\epsilon} \frac{T_2}{T_1} (11)$$

If the change takes place at *constant pressure*, $p_2 = p_1$ and (8) becomes

$$\begin{aligned}\phi_2 - \phi_1 &= C_v \log_{\epsilon} \frac{p_2}{p_1} + C_p \log_{\epsilon} \frac{v_2}{v_1} \\ &= C_p \log_{\epsilon} \frac{v_2}{v_1} (12)\end{aligned}$$

Expression for the Change of Entropy when the Operation takes place according to the General Law $pv^n = \text{Constant}$.—It

has been shown in Art. 14 (5) that the heat supplied or taken from the gas is given by

$$H = \frac{\gamma - n}{\gamma - 1} \times \text{work done.}$$

Considering a small change in state we may write

$$\delta H = \frac{\gamma - n}{\gamma - 1} \times p \delta v$$

Dividing by T we have

$$\frac{\delta H}{T} = \frac{\gamma - n}{\gamma - 1} \times \frac{p}{T} \delta v$$

or since $\frac{p}{T} = \frac{R}{v}$ from (3) we have in the limit

$$\frac{dH}{T} = \frac{\gamma - n}{\gamma - 1} \times R \frac{dv}{v}$$

Integrating we have

$$\int_{T_1}^{T_2} \frac{dH}{T} = R \times \frac{\gamma - n}{\gamma - 1} \int_{v_1}^{v_2} \frac{dv}{v}$$

$$\phi_2 - \phi_1 = R \times \frac{\gamma - n}{\gamma - 1} \cdot \log_e \frac{v_2}{v_1}$$

But

$$\frac{v_2}{v_1} = \left(\frac{T_1}{T_2} \right)^{\frac{1}{n-1}} \text{ from (4), Art. 11}$$

and

$$R = C_v(\gamma - 1) \text{ from (2), Art. 7}$$

hence

$$\phi_2 - \phi_1 = R \times \frac{\gamma - n}{\gamma - 1} \cdot \log_e \left(\frac{T_1}{T_2} \right)^{\frac{1}{n-1}}$$

$$= C_v(\gamma - 1) \times \frac{\gamma - n}{\gamma - 1} \times \frac{1}{n-1} \log_e \frac{T_1}{T_2}$$

$$= C_v \cdot \frac{\gamma - n}{n-1} \log_e \frac{T_1}{T_2} \dots \dots \dots (13)$$

EXAMPLE.—Find the change in entropy when one pound of air at 32° F. and atmospheric pressure changes in volume to 2 cubic feet with a temperature of 539° F. given $C_p = 0.2375$ and $C_v = 0.1691$.

We may use either of the equations (4), (8), or (9), Art. 16.

Here

$$p_1 = 14.7 \times 144 = 2116 \text{ pounds per square foot}$$

$$v_1 = \frac{53.18 \times 493}{2116} = 12.39 \text{ cubic feet}$$

$$T_1 = 32 + 461 = 493^\circ \text{ absolute}$$

$$T_2 = 539 + 461 = 1000^\circ \text{ absolute}$$

$$v_2 = 2 \text{ cubic feet.}$$

Using equation (4), Art. 16, we get.

$$R = C_p - C_v = 0.2375 - 0.1691 = 0.0684 \text{ or } 53.18 \text{ foot-pounds}$$

$$\phi_2 - \phi_1 = C_v \log_e \frac{T_2}{T_1} + R \log_e \frac{v_2}{v_1}$$

$$= 0.1691 \log_e \frac{1000}{493} + 0.0684 \log_e \frac{2}{12.39}$$

$$= 0.1196 - 0.1247$$

$$= -0.0051 \text{ rank.}$$

Using equation (8), Art. 16, we get

$$\begin{aligned} p_2 v_2 &= RT_2 \\ p_2 &= \frac{RT_2}{v_2} = \frac{53.18 \times 1000}{2} = 26,590 \text{ pounds per square foot} \end{aligned}$$

$$\begin{aligned} \phi_2 - \phi_1 &= C_v \log_{\epsilon} \frac{p_2}{p_1} + C_p \log_{\epsilon} \frac{v_2}{v_1} \\ &= 0.1691 \log_{\epsilon} \frac{26,590}{2116} + 0.2375 \log_{\epsilon} \frac{2}{12.39} \\ &= 0.4280 - 0.4331 = -0.0051 \text{ rank.} \end{aligned}$$

Also by equation (9) Art. (16)

$$\begin{aligned} \phi_2 - \phi_1 &= C_p \log_{\epsilon} \frac{T_2}{T_1} - R \log_{\epsilon} \frac{p_2}{p_1} \\ &= 0.2375 \log_{\epsilon} \frac{1000}{493} - 0.0684 \log_{\epsilon} \frac{26,590}{2116} \\ &= 0.1680 - 0.1731 = -0.0051 \text{ rank.} \end{aligned}$$

The gain of entropy ($\phi_2 - \phi_1$) being negative means that during the change of state the air *loses* entropy by the amount 0.0051 rank.

17. Work done by an Expanding Gas from Consideration of the Temperature Entropy Diagram.—Let T_1 be the initial

temperature of the gas and T_2 the final temperature after expansion, and let AB (Fig. 4) represent the temperature-entropy curve for the expansion. Further, suppose δH is a small quantity of heat supplied at any temperature T , and giving rise to a small change of entropy $\delta\phi$.

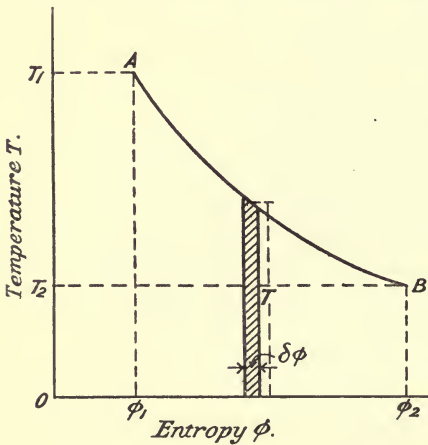

FIG. 4.

The total area under the curve AB is

$$\int_{\phi_1}^{\phi_2} T d\phi = H$$

the total heat supplied during the expansion.

Similarly if the gas is compressed from temperature T_2 to temperature T_1 it will reject an amount of heat equal to the above.

Suppose now the gas undergoes a complete cycle of changes so that its temperature, pressure, and volume are the same at the end as at the beginning of the cycle. The temperature-entropy diagram will then form a closed figure as in the case given in Fig. 3.

Let H_1 be the amount of heat supplied to the gas, and H_2 the amount rejected by the gas during the cycle, then, in order to get the area of the closed figure we must integrate over the whole cycle, and we obtain

$$\int Td\phi = H_1 - H_2$$

Now $H_1 - H_2$ is equal to the heat converted into work, hence we see that the area of the temperature-entropy diagram represents to some scale the work done in a complete cycle.

EXAMPLES I

1. Find the volume of 3 pounds of air when at a pressure of 70 pounds per square inch absolute and at a temperature of 75° F. [Take $C_p = 183.4$ foot-pounds and $C_v = 130.2$ foot-pounds.]

2. If 1 pound of air at 32° F. has its volume doubled at constant atmospheric pressure, what is its final temperature? How much external work is done during the expansion and how much heat must be supplied during the expansion? [$C_p = 0.2375$.]

3. A cylinder contains 0.5 cubic foot of gas at 15 pounds per square inch absolute. Find the work expended in compressing it to a pressure of 90 pounds per square inch absolute, the law of compression being $p v^{1.35} = \text{constant}$.

4. The area of an engine piston is 100 square inches. If the length of cylinder occupied by gas is 18 inches when the pressure is 120 pounds per square inch absolute, find the work done by the gas in driving the piston through a distance of 2 feet. Take the law of expansion as $p v^{1.3} = \text{constant}$.

5. Find the work done by the gas in Question 4, if the gas is kept at constant temperature during the expansion.

6. In a gas engine cylinder 5 cubic feet of gas and air at 14.7 pounds per square inch absolute are compressed into a clearance space of 1 cubic foot. If the compression is adiabatic, (a) what is the pressure at the end of the compression stroke? and (b) how many foot-pounds of work must be expended in the compression of the charge? [$\gamma = 1.4$.]

7. If 0.1 pound of gas occupying 0.5 cubic foot is expanded in a cylinder at constant pressure of 150 pounds per square inch absolute until its volume is 1 cubic foot, and is then expanded adiabatically to 5 cubic feet, find the temperature of the gas, (a) at the end of the constant pressure stage, (b) at the end of the adiabatic expansion, and calculate the heat expended and the work done during each portion of the process. Take $C_p = 198$ foot-pounds and $C_v = 144$ foot-pounds. [L. U.]

8. The temperature of the mixture of gas and air in a gas engine at the end of the admission stroke is 90° F. and the pressure 15 pounds per square inch absolute. The clearance volume is 4.6 cubic feet, and the total volume of clearance plus piston displacement is 12 cubic feet. Assuming adiabatic compression $p v^{1.4} = \text{constant}$, determine the temperature at the end of the compression stroke.

If the pressure after ignition is 240 pounds per square inch, find the temperature in the cylinder. [L. U.]

9. In a certain oil engine the piston displacement is 0.395 cubic foot and the volume of the clearance space 0.210 cubic foot, and the pressure of the charge at the instant compression begins is 13 pounds per square inch absolute. Find the compression pressure and the temperature reached at the end of the compression stroke if the temperature of the charge at the instant compression began was 264° F. Assume the law of compression to be $p v^{1.39} = \text{constant}$. [L. U.]

10. If 20 cubic feet of dry air are compressed adiabatically from 15 pounds per square inch absolute and 60° F. to 225 pounds per square inch absolute, find the temperature after the compression and the work expended. [Take $\gamma = 1.4$.]

11. If 13 cubic feet of air at 60° F. and 200 pounds per square inch absolute are expanded to a pressure of 25 pounds per square inch absolute, calculate the final volume and the work done during the expansion (a) if the expansion is isothermal, (b) if the expansion is adiabatic.

12. The law of the expansion curve of a gas engine indicator diagram is found to be $p v^{1.57} = \text{constant}$. Assuming $\frac{C_p}{C_v} = 1.37$ find the rate of heat reception $\frac{dH}{dv}$. If the

law of the compression curve is $p v^{1.25} = \text{constant}$, what is the rate of heat reception during compression? If the piston speed is 600 feet per minute when the pressure on the expansion curve is 150 pounds per square inch absolute, what is the rate of heat reception per second at this instant?

13. Air at 15 pounds per square inch absolute is drawn into a cylinder and compressed adiabatically to 135 pounds per square inch absolute, and is then expelled at this pressure into a receiver; its original temperature was 50° F. In the receiver the compressed air cools to 50° F., and in order to maintain a uniform pressure in the receiver an equal weight of compressed air is drawn off constantly and expanded isothermally down to 15 pounds per square inch absolute. Calculate (a) the work spent per cubic foot of air in the compressor; (b) the work done per cubic foot of air in expanding; (c) the temperature of the air as it enters the receiver.

14. If 1 pound of air occupying 3 cubic feet at 15,950 pounds per square foot, and absolute temperature 900° F., expands at constant temperature to a volume of 12 cubic feet, find its pressure after expansion, the heat taken in, and the gain in entropy.

15. If 42.46 cubic feet of air at pressure 676 pounds per square foot and absolute temperature 539° F., be compressed isothermally to volume 10.62 cubic feet, what is its pressure after compression, the work done on it, the heat taken from it, and the loss of entropy?

16. Ten cubic feet of air at 65° F. and 90 pounds per square inch absolute are expanded to 4 times the original volume, the law of the expansion curve being $p v^{1.25} = \text{constant}$. Given $C_p = 130.2$ foot-pounds, find the change of entropy. [Take $\gamma = 1.4$.]

CHAPTER II

HOT-AIR ENGINES

18. Classification and General Remarks.—Hot-air engines may be divided into two classes: (1) external and (2) internal combustion engines. In the first class the working substance is atmospheric air which receives heat from an external furnace by conduction through the containing vessel or heater, in the same way that steam in a steam boiler receives heat through the plates or tubes of the boiler. In the second class the working substance is the products of combustion (a mixture of gases) of fuel, maybe solid, liquid, or gaseous, which takes place within the engine itself. In its widest sense, then, the second class includes both gas and oil engines, which are however dealt with separately in Chapters XIII. and XV.

Compared with a steam engine using saturated steam, an air engine has the advantage that the temperature and pressure of the working substance are independent of one another. In any heat engine which uses a saturated vapour as the working substance, the upper temperature limit must be, for mechanical reasons, comparatively low, in consequence of the exceedingly high pressures which accompany very high temperatures. In an air engine, however, it is possible to use an upper temperature limit greatly in excess of that permissible in a steam engine, and it will easily be seen that if the lower temperature limit is not raised, an increase of thermodynamic efficiency results, since the efficiency of a heat engine depends upon the working range of temperature (Art. 21).

Although by using superheated steam in a steam engine we may raise the upper temperature limit, yet the steam continues to take in the greater part of its heat at the comparatively low temperature of evaporation in the boiler, and in consequence the thermodynamic efficiency is correspondingly reduced, since for maximum efficiency a heat engine must take in *all* its heat at the highest temperature and reject all at the lowest temperature (Art. 24).

In the case of the external combustion air engine, there must be a considerable drop in temperature between the temperature of combustion in the furnace and the temperature of the air in the containing vessel. This drop in temperature is, of course, essential in order to have rapid conduction of heat through the walls of the heater, but it results in a lower efficiency. Internal combustion engines, therefore, have the advantage that the temperature of combustion in the engine itself is the upper limit in the thermodynamic cycle.

The drawback to the use of the external combustion engine is the large heating surface of metal which is required to supply the air with

heat, and this large surface, always kept at a very high temperature, soon burns out.

19. Graphic Representation of the Work done during the Change in Volume of a Fluid.—

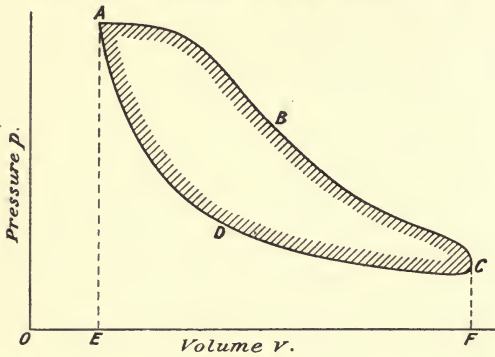

FIG. 5.

Let Fig. 5 represent the pressure-volume diagram, in which the ordinates represent the pressure of the working fluid, and the abscissæ the volume. The distance OE represents the initial volume of the working fluid, and EA the initial pressure. The fluid expands along any curve such as ABC to a volume OF and pressure FC, the area under this curve representing to some scale the work done by the fluid during the expansion. Let compression then take

place along the curve CDA, during which work is done *on* the fluid represented to the same scale by the area under this curve. The shaded area, therefore, represents the difference of these quantities, which is equal to the net amount of work done by the fluid during the process. Such a diagram is called the pressure-volume or indicator diagram.

In general terms—

Heat taken in = work done + heat rejected

Area EABCF = shaded area ABCD + area EADCF

20. Cycles of Operation.—The working substance receives heat from the heat source, expands in a cylinder doing useful work, and then rejects the heat which is not used to a cold body or condenser. The working substance then receives heat again, and the same cycle of operations is performed, so that after each cycle the substance returns to the same state of pressure, volume, and temperature as it started from; in other words, it passes through a *closed* cycle. There are thus three essential organs of a heat engine: (1) a hot body; (2) a cold body; (3) the working fluid.

21. Carnot's Cycle.—Carnot, in 1824, showed that the amount of heat which could be converted into mechanical work by an ideal perfect heat engine using a perfect gas as the working fluid, *depended solely upon the working range of temperature.* Since no gas is perfect, and in practice a perfect engine cannot be constructed, the Carnot cycle affords a ready means of comparing the actual performance of any engine, with the best theoretical performance possible under the same working range of temperature.

Fig. 6 shows at (a) the pressure-volume or indicator diagram of an engine working on this cycle. Starting at point *a* the gas expands isothermally at constant temperature T_1 , heat being supplied to keep the temperature constant, from volume v_a to volume v_b . The supply of heat is then shut off and the gas expands adiabatically to volume v_c the temperature

falling to T_2 . On the return stroke of the piston the gas is compressed isothermally from volume v_c to volume v_d at constant temperature T_2 , heat being taken from it to keep the temperature constant, the cycle being completed by compressing adiabatically from volume v_d and temperature T_2 to volume v_a and temperature T_1 . A closed cycle is thus obtained, the pressure, volume, and temperatures of the gas being the same at the end as at the beginning of the cycle.

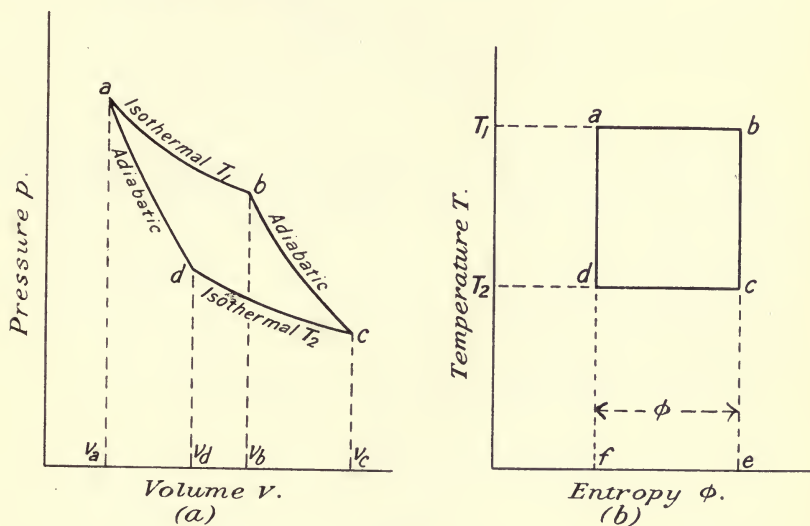

FIG. 6.

To find the Proper Place to stop the Isothermal Compression.—The point d must be so chosen that an adiabatic drawn through it will pass through the starting point a .

By Art. 11 we have, by equation (4)—

$$\frac{T_1}{T_2} = \left(\frac{v_c}{v_b}\right)^{\gamma-1}$$

for the cooling during the adiabatic expansion stage from b to c .

Also for the heating during the adiabatic compression stage from d to a we have

$$\frac{T_1}{T_2} = \left(\frac{v_d}{v_a}\right)^{\gamma-1}$$

Hence
$$\left(\frac{v_c}{v_b}\right)^{\gamma-1} = \left(\frac{v_d}{v_a}\right)^{\gamma-1} \quad \text{or} \quad \frac{v_c}{v_b} = \frac{v_d}{v_a}$$

and therefore
$$\frac{v_c}{v_d} = \frac{v_b}{v_a}$$

This shows that the point d must be so chosen that *the ratio of isothermal compression is the same as the ratio of isothermal expansion.*

Efficiency of the Cycle.—Let r denote the ratio of isothermal expansion or compression, then we have during

the stage ab Heat taken in $= RT_1 \log_e r =$ work done *by* the gas

bc No heat taken in or rejected

cd Heat rejected $= RT_2 \log_e r =$ work done *on* the gas

da No heat taken in or rejected

$$\begin{aligned} \text{Now efficiency} &= \frac{\text{heat converted into mechanical work}}{\text{heat supplied}} \\ &= \frac{RT_1 \log_e r - RT_2 \log_e r}{RT_1 \log_e r} \\ &= \frac{T_1 - T_2}{T_1} \dots \dots \dots (4) \end{aligned}$$

Derivation of this Result from the Temperature-Entropy Diagram.—The temperature-entropy diagram is shown in Fig. 6, at (b), since the area of the temperature-entropy diagram represents the work done (Art. 17).

The work done *by* the gas during the stage ab is represented by area $fabe = \phi T_1$.

The work done *on* the gas during the stage cd is represented by area $fdce = \phi T_2$.

$$\begin{aligned} \text{Therefore net work done} &= fabe - fdce = \text{area } dabc \\ &= \phi \times (T_1 - T_2) \end{aligned}$$

$$\begin{aligned} \therefore \text{efficiency} &= \frac{\text{area } dabc}{\text{area } fabc} \\ &= \frac{\phi(T_1 - T_2)}{\phi T_1} = \frac{T_1 - T_2}{T_1} \dots \dots \dots (4) \end{aligned}$$

22. Carnot's Cycle reversed.—If the cycle be reversed, starting at point c of the indicator diagram, Fig. 6, it will be found that over the cycle a net amount of work has been done *on* the gas equal in amount to the net amount of work done *by* the gas during the forward cycle just considered, and that this reversal of the work has been accompanied by an exact reversal of each of the transfers of heat during stages ab and cd . An engine in which this is possible is called from a thermodynamic point of view a *reversible engine*, and it is only the ideally perfect engine which is reversible.

23. Carnot's Principle states that no other heat engine can be more efficient than a reversible engine when both work between the same limits of temperature. Carnot's method of reasoning may be stated thus:—

Imagine two engines P and Q of which P is reversible, and let them both work by taking in heat from a hot body A and rejecting heat to a cold body C. Let H_A be the quantity of heat which P takes in from A for each unit of work that it does, and let H_C be the quantity that it rejects to C. Let Q be more efficient than P, then it will take in less heat from A (say $H_A - q$) and reject less (say $H_C - q$) to C than P would for each unit of work done.

Now let Q work directly, converting heat into work, and drive P as a reversed heat engine (P converting work into heat). Then for every unit of work done by Q on P, $H_A - q$ heat units are taken from A by Q, whilst

H_A units of heat will be returned to A by the reversed action of P. Hence the hot body A on the whole would gain heat by the amount “ q ” for every unit of work done by Q on P.

Again, Q gives to the cold body C a quantity of heat $H_0 - q$ while P takes from C an amount H_0 ; hence the cold body C loses an amount of heat “ q ” for every unit of work done by Q on P; therefore the combined action would result in a transfer of heat from the cold body C to the hot body A.

Now the second law of thermodynamics, Art. 25, says that this is impossible, therefore Q is *not* more efficient than P, from which we conclude that Q and P must have the same efficiency.

24. Conditions for Maximum Efficiency.—We have already seen in Art. 21 that the amount of heat which can be turned into mechanical work depends upon the working range of temperature. However great the quantity of heat available, if there is no range of temperature, *i.e.* if $T_1 = T_2$, there can be no work done. The only possible case in which a perfect engine could have an efficiency of unity would be when $T_2 = 0$, that is when the lower temperature limit is the absolute zero of temperature. It is obvious that this temperature can never be attained in practice. Again, if any of the heat is taken in below the higher temperature T_1 , and any rejected above the lower temperature T_2 , that portion of the heat will have less availability for conversion into work, since the range of temperature for this quantity of heat will obviously be less than $T_1 - T_2$; therefore one condition for the maximum efficiency will be that the engine must take in *all* its heat at the higher temperature, and reject *all* at the lower temperature. Further, when the temperatures of reception (T_1) and rejection (T_2) are fixed the engine will have a maximum efficiency when it is reversible (Art. 23).

It is therefore essential to see what conditions must be fulfilled in order that the engine may be reversible. A transfer of heat from the source to the working substance can only be reversible when both are at the same temperature, and an expansion is reversible only when it does work on the engine piston without wasting energy in setting itself in motion. This therefore excludes free or imperfectly resisted expansion, which occurs when a gas expands freely through an orifice. A similar condition of course applies to the compression of the working substance.

The conditions for maximum efficiency may therefore be summed up briefly as follows:—

(1) The engine must take in all its heat at the highest temperature, and reject all at the lowest temperature.

(2) The working substance must, when receiving heat, be at the temperature of the source from which the heat comes, and it must, when giving up heat, be at the temperature of the body to which the heat is rejected.

(3) All free or imperfectly resisted expansion and compression must be avoided.

Condition (1) is satisfied by Carnot's ideal engine in which the temperature of the working substance changes from T_1 to T_2 by adiabatic expansion, and from T_2 to T_1 by adiabatic compression, thereby being enabled to take in and reject heat at the end of the range without taking in or rejecting any by the way.

Since the inclination of the adiabatic and isothermal curves for a gas is small, the area of the indicator diagram, and consequently the work done per revolution is small in comparison with the quantity of heat supplied and rejected. Hence an air engine using Carnot's cycle would in consequence be excessively large and mechanically inefficient.

25. The Second Law of Thermodynamics.—This law may be stated in various forms. As stated by Clausius the second law says:—*It is impossible for a self-acting engine unaided by any external agency to convey heat from one body to another at a higher temperature.*

Rankine's statement of the second law is as follows:—*If the absolute temperature of any uniformly hot substance be divided into any number of equal parts, the effect of those parts in causing work to be performed is equal.*

The first law of thermodynamics (Art. 1) might lead one to think that an engine can convert *all* the heat it receives into useful work, but in con-

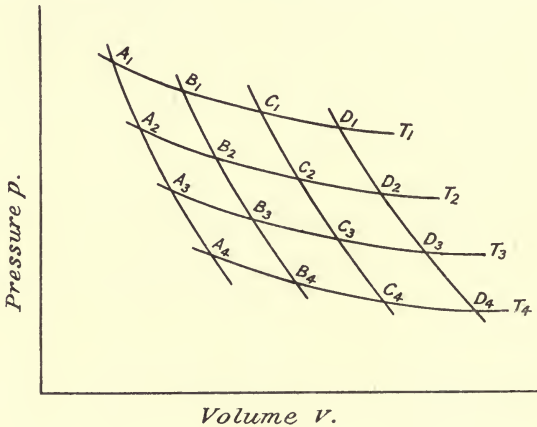

FIG. 6A.

sequence of the second law only a fraction of the heat supplied can be so converted (Art. 21). The ratio

$$\frac{\text{heat converted into useful work}}{\text{heat taken in by the engine}}$$

is always less than unity, and is called the efficiency of the engine considered as a heat engine.

26. Rankine's Statement of the Second Law represented Graphically.—In Fig. 6A let $A_1B_1C_1D_1$; $A_2B_2C_2D_2$; $A_3B_3C_3D_3$, etc., represent a series of isothermal curves for temperatures, T_1 , T_2 , T_3 , etc., such that $T_1 - T_2 = T_2 - T_3 = T_3 - T_4 = \delta T$, and so on, there being equal intervals of temperature δT between successive isothermals, and let a series of adiabatic curves $A_1A_2A_3A_4$; $B_1B_2B_3B_4$; $C_1C_2C_3C_4$, etc., be drawn to cut these isothermals in such a manner that the areas $A_1B_1B_2A_2$; $A_2B_2B_3A_3$; $B_1C_1C_2B_2$, etc., are all equal.

Consider the portion of the diagram $A_1B_1B_2A_2$. This represents an engine indicator diagram working on the Carnot Cycle (Art. 21).

Let Q = quantity of heat supplied during the isothermal expansion A_1B_1 .

Then work done = area of $A_1B_1B_2A_2 = Q \times \frac{T_1 - T_2}{T_1}$ (see Art. 21).

$$= Q \times \frac{\delta T}{T_1} \dots \dots \dots (1)$$

and heat rejected = $Q - Q \times \frac{T_1 - T_2}{T_1}$

$$= Q \left(1 - \frac{T_1 - T_2}{T_1} \right) = Q \times \frac{T_2}{T_1}$$

Now consider the cycle $A_2B_2B_3A_3$. The heat supplied during the isothermal A_2B_2 is the heat rejected during the cycle $A_1B_1B_2A_2$ or

$$\text{Heat supplied} = Q \times \frac{T_2}{T_1}$$

Work done = heat supplied \times efficiency

$$= Q \times \frac{T_2}{T_1} \times \frac{T_2 - T_3}{T_2}$$

$$= Q \times \frac{T_2}{T_1} \times \frac{\delta T}{T_2} = Q \times \frac{\delta T}{T_1} \dots (2)$$

and heat rejected = heat supplied - work done

$$= Q \times \frac{T_2}{T_1} - Q \times \frac{\delta T}{T_1} = Q \left(\frac{T_2}{T_1} - \frac{\delta T}{T_1} \right) = Q \left(\frac{T_2 - T_2 - T_3}{T_1} \right) = Q \times \frac{T_3}{T_1}$$

Similarly we should find for the cycle $A_3B_3B_4A_4$

$$\text{work done} = Q \times \frac{\delta T}{T_1}$$

and heat rejected = $Q \times \frac{T_4}{T_1}$

Hence the work done during each cycle is the same, and each cycle takes place between the same range of temperature.

Rankine's statement may therefore be understood as meaning that each of the equal intervals into which any range of temperature may be divided is equally effective in allowing work to be produced from heat, when the heat is made to pass through all the equal intervals from the top to the bottom of the range of temperature in the most efficient way possible, *i.e.* on the Carnot Cycle.

The above also gives us a new *definition of temperature*, *i.e.* equal intervals of temperature are those intervals which give equal amounts of work done in a series of perfect heat engines, each handing on its exhaust to the next engine.

The air thermometer gives a scale which depends on either the expansion of air at constant pressure or at constant volume, these again depending upon the assumption that air is a perfect gas. The above scale (due to the late Lord Kelvin) would therefore agree exactly with that of an air thermometer if air were a perfect gas.

Absolute Zero of Temperature.—It has been shown in Art. 21 that a perfectly reversible heat engine working between absolute temperatures T_1

and T_2 , and supplied with a quantity of heat H , would convert $H \times \frac{T_1 - T_2}{T_1}$ units of heat into work. To convert *all* the heat into work, and hence have an efficiency of unity, the lower temperature limit T_2 must obviously be zero in the above expression. Lord Kelvin fixed upon this temperature as the absolute zero from which all temperatures could be measured.

It is impossible in practice to attain the second condition, because if the temperature of the working substance and that of the source of heat were the same, no transfer of heat could take place. If, however, the working substance while changing from temperature T_1 to temperature T_2 be made to deposit heat in some body within the engine in such a manner that this transference of heat is reversible (satisfying condition 2, Art. 24), and then, when changing back again from T_2 to T_1 absorb the heat from the body which it deposited there, this alternate storing and restoring of

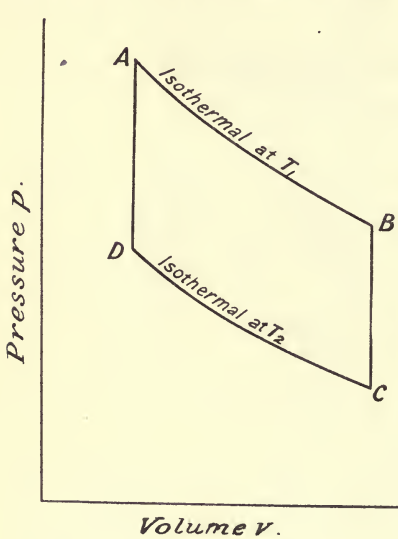

FIG. 7.

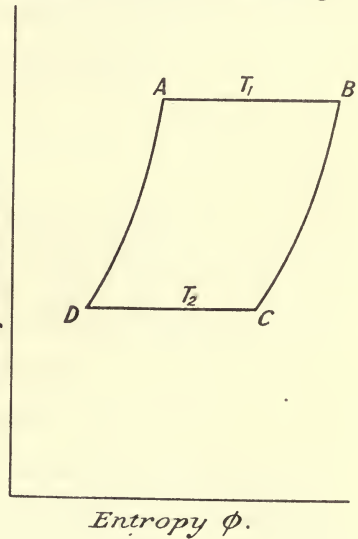

FIG. 8.

heat would serve, instead of adiabatic expansion and compression, to make the temperature of the working substance pass from T_1 to T_2 , and from T_2 to T_1 respectively, and the cycle would be reversible.

27. Stirling's Air Engine with Regenerator.—In 1827 Stirling designed and patented an apparatus called a regenerator by which this process of alternate storing and *re*-storing of heat could be performed. Fig. 7 shows the indicator diagram of the engine, and Fig. 8 the temperature-entropy diagram. The cycle of operations was as follows:—

Stage AB.—Air, which has been previously heated to temperature T_1 by passing through the regenerator, expands isothermally in the engine cylinder through a ratio r taking in heat during the expansion. The amount of heat taken in per pound of air is equal to the work done $= RT_1 \log_e r$. The energy stored up in the flywheel of the engine carries the engine through the remainder of the cycle.

Stage BC.—The air passes *at constant volume* through the regenerator, its temperature falling to T_2 , the pressure falling with the temperature. The amount of heat stored in the regenerator = $C_v(T_1 - T_2)$.

Stage CD.—The air is next compressed isothermally by the engine piston to its original volume, being in contact with the regenerator at temperature T_2 . The amount of heat rejected is equal to the work done on the air = $RT_2 \log_e r$.

Stage DA.—The air now passes through the regenerator *at constant volume*, its temperature rising from T_2 to T_1 . The amount of heat taken in from the regenerator = $eC_v(T_1 - T_2)$, where e is the efficiency of the regenerator.

$$\text{Efficiency} = \frac{\text{work done or heat converted into work}}{\text{heat supplied}}$$

$$\text{Now heat supplied} = RT_1 \log_e r + C_v(T_1 - T_2) \times (1 - e)$$

$$\text{heat rejected} = RT_2 \log_e r + C_v(T_1 - T_2) \times (1 - e)$$

$$\therefore \text{work done} = \text{heat supplied} - \text{heat rejected}$$

$$= R(T_1 - T_2) \log_e r$$

$$\therefore \text{efficiency} = \frac{R(T_1 - T_2) \log_e r}{RT_1 \log_e r + (1 - e)C_v(T_1 - T_2)} \dots (1)$$

If the efficiency of the regenerator be unity,

$$\text{efficiency} = \frac{R(T_1 - T_2) \log_e r}{RT_1 \log_e r} = \frac{T_1 - T_2}{T_1} \dots (2)$$

In any case the efficiency may be taken as $\frac{T_1 - T_2}{T_1}$ approximately, since in practice e can be made as high as 0.9.

At a Dundee foundry in 1845 a double-acting Stirling engine, cylinder 16 inches diameter by 4 feet stroke, at 80 revs. per min. gave about 50 I.H.P. with 1.7 pounds of coal per I.H.P. hour. The working temperatures were $t_1 = 650^\circ \text{F.}$, and $t_2 = 150^\circ \text{F.}$, and the ideal efficiency was therefore $\frac{650 - 150}{650 + 460} = 0.45$.

This result was reduced to 0.3 by practical imperfections, and the coal consumption came out to about 2.7 lbs. per B.H.P. hour. After three years' working the engine was abandoned owing to the burning out of the heater.

28. Ericsson's Air Engine with Regenerator.—In this engine the air was heated from T_2 to T_1 by being passed through the regenerator *at constant pressure*. Its principal feature consisted in the fact that the working cylinder was heated directly at one end, and the air was compressed in a separate pump worked off the engine shaft. As fitted in the steamer *Ericsson*, the engine consisted of a set of four cylinders each 14 feet diameter \times 6 feet stroke, each with its own compressing pump, all driving the same shaft, and communicating with the same receiver, making their strokes in succession at intervals of a quarter of a revolution. By this means a fairly steady speed was maintained, the engine running at 9 revolutions per minute.

Fig. 9 shows the pressure-volume diagram and Fig. 10 the temperature-entropy diagram for the cycle, which is as follows:—

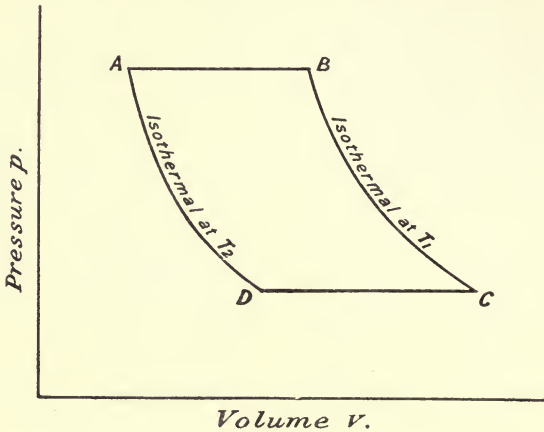

FIG. 9.

First Stage, AB.—Compressed air at T_2 is drawn into the working cylinder through the regenerator and expands at *constant pressure* from absolute temperature T_2 to T_1 .

$$\text{Heat taken in from regenerator} = C_p(T_1 - T_2)e.$$

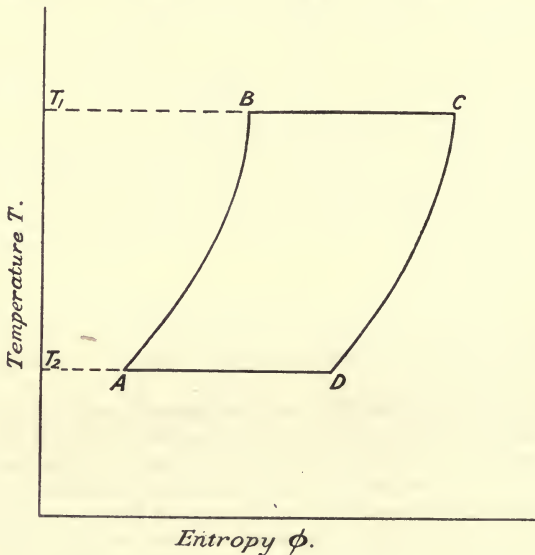

FIG. 10.

Second Stage, BC.—The admission valve is closed and the air expands isothermally at temperature T_1 .

$$\text{Heat supplied by furnace} = RT_1 \log_e r.$$

Third Stage, CD.—The air is discharged through the regenerator at constant pressure and there stores up a quantity of heat = $C_p(T_1 - T_2)$.

Fourth Stage, DA.—Isothermal compression at T_2 and heat stored = $RT_2 \log_e r$.

$$\begin{aligned} \text{Net amount of work done} &= RT_1 \log_e r - RT_2 \log_e r \\ \text{heat supplied} &= RT_1 \log_e r + C_p(T_1 - T_2) \times (1 - e) \\ \text{Hence efficiency} &= \frac{R(T_1 \log_e r - T_2 \log_e r)}{RT_1 \log_e r + C_p(T_1 - T_2)(1 - e)} \quad (1) \end{aligned}$$

If the efficiency of regenerator (e) be unity—

$$\text{efficiency of engine} = \frac{R(T_1 - T_2) \log_e r}{RT_1 \log_e r} = \frac{T_1 - T_2}{T_1} \quad (2)$$

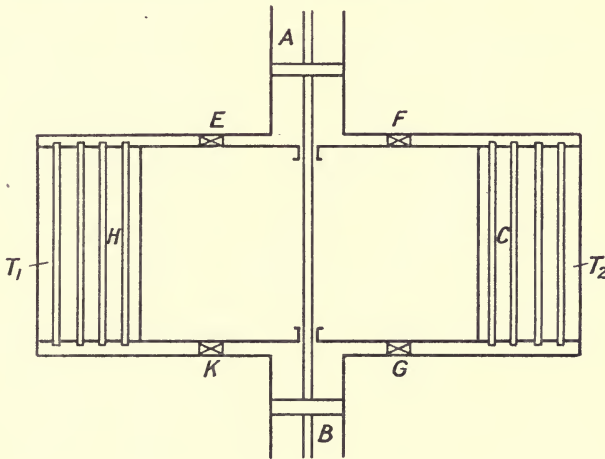

FIG. 11.

If a regenerator is not fitted, the efficiency will obviously be

$$\frac{R(T_1 - T_2) \log_e r}{RT_1 \log_e r + C_p(T_1 - T_2)} \dots \dots \dots (3)$$

The only difference between the expression for the efficiency of the Stirling engine, Art. 27, Equation (1), and that of the Ericsson engine given by Equation (1) above, is that for the Ericsson Engine C_p , the specific heat of air at constant pressure, must be written instead of C_v , the specific heat at constant volume.

Like all other hot-air engines the Ericsson engine had a very low mechanical efficiency, and failed because of the too small heating surface which very soon burnt away.

29. Joule's Air Engine.—In 1851 Dr. Joule proposed to use an air engine in which the regenerator and refrigerator are dispensed with. Although no hot-air engine was constructed to work on this cycle, it for several reasons possesses great interest, as will be seen later.

Fig. 11 is a diagrammatic sketch of the engine. H is a hot chamber containing air under compression and heated by, say, a furnace and kept at

a uniform absolute temperature T_1 ; C is a cold chamber full of air at temperature T_2 ; B is a compressing cylinder by which air may be pumped from C into H. A is the working cylinder in which the air may be allowed to expand before passing into the chamber C.

Assuming the chambers H and C are large in comparison with the volume of air which passes in each stroke, it follows that the pressures in these chambers will remain practically constant.

The cycle of operations is as follows:—

The air is heated in H to temperature T_1 and then the valve E opens and the air passes into A and, E being then closed, expands adiabatically to temperature T_2 . At the same time the same quantity of air is drawn through valve G by the pump B from the chamber C, and compressed

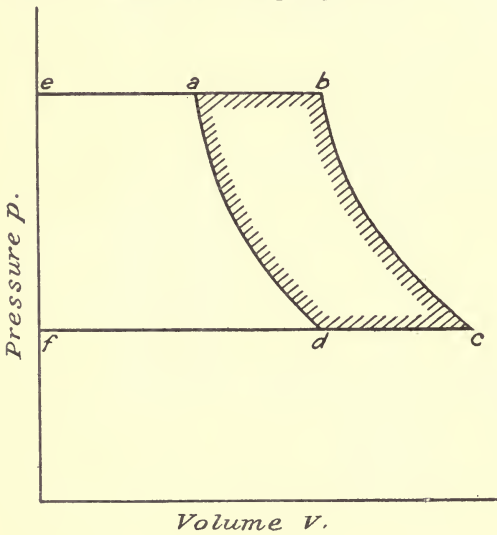

FIG. 12.

adiabatically until its pressure is the same as the pressure in H, at which point the valve K opens and the air flows into H, where its temperature is raised again to T_1 . The air after expansion in the working cylinder A is exhausted through the valve F into the cold chamber C at a temperature T_2 .

The pressure-volume diagram is shown in Fig. 12, that for the pump is $fdac$, the area of which represents the work done on the air during compression, and that for the engine $ebcf$. The difference between the two areas, namely area $abcd$,

represents the net amount of work done during one complete cycle.

Fig. 13 shows the corresponding temperature-entropy diagram.

$$\text{Heat taken in } Q_H = C_p(T_b - T_a) \quad \dots \quad (1)$$

$$\text{Heat rejected } Q_C = C_p(T_c - T_d) \quad \dots \quad (2)$$

Now since the expansion and compression both take place between the same terminal pressures, the ratio of expansion and compression is the same. Calling the ratio " r " we have

$$\frac{T_a}{T_d} = \frac{T_b}{T_c} = r^{\gamma-1}$$

Also

$$\frac{T_b}{T_a} = \frac{T_c}{T_d}$$

$$\therefore \frac{T_b - T_a}{T_a} = \frac{T_c - T_d}{T_d} \quad \text{or} \quad \frac{T_b - T_a}{T_c - T_d} = \frac{T_a}{T_d} = \frac{T_b}{T_c} = r^{\gamma-1}.$$

$$\text{Now } \frac{Q_H}{Q_C} = \frac{T_b - T_a}{T_c - T_d} \text{ from (1) and (2)}$$

$$\therefore \frac{Q_H}{Q_C} = \frac{T_a}{T_d} = \frac{T_b}{T_c}$$

$$\text{And efficiency} = \frac{Q_H - Q_C}{Q_H} = \frac{T_a - T_d}{T_a} = \frac{T_b - T_c}{T_b} \dots \dots (3)$$

Now $T_b = T_1$, the upper temperature limit,
and $T_d = T_2$, the lower " "

Hence the efficiency is less than that of a perfect engine working between the same temperature limits $\left(\frac{T_1 - T_2}{T_1}\right)$ because the heat is not taken in and rejected at the extreme temperatures.

Instead of the working air being heated from an external source as Joule originally intended, we may have combustion going on inside the hot chamber itself, the combustion being kept up by a supply of fresh air from the compressing pump with, of course, a supply of fuel itself. In other words, the engine may take the form of an *internal combustion* engine, and although engines, essentially of the Joule type, using *solid* fuel, have been used on a small scale, the most important development of this type of engine is the explosive gas and oil engine.

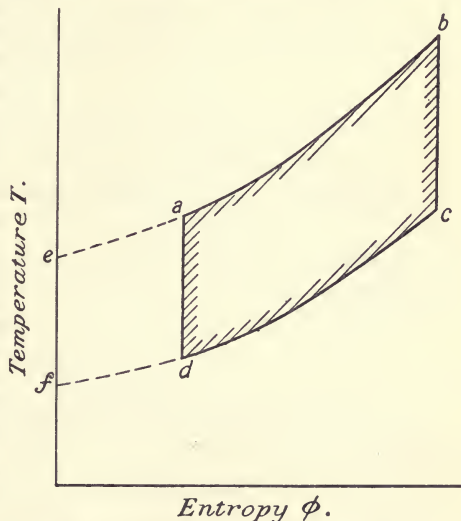

FIG. 13.

Another development of the Joule engine has found application in the reversed form, in which the reversed heat engine becomes a refrigerating machine, for example, the Bell-Coleman refrigerating machine, for a description of which the reader is referred to Chapter VII.

EXAMPLE 1.—A Stirling air engine works between temperatures of 800° F. and 90° F., the ratio of isothermal expansion being 2. Calculate the ideal efficiency when (a) the engine is fitted with a perfect regenerator; (b) when efficiency of regenerator is 0.9. Take $C_p = 0.2375$ and $C_v = 0.1691$.

$$\text{Here } T_1 = 800 + 460 = 1260$$

$$T_2 = 90 + 460 = 550$$

$$\text{and } R = C_p - C_v = 0.2375 - 0.1691 = 0.0684$$

$$(a) \text{ Efficiency} = \frac{T_1 - T_2}{T_1} = \frac{1260 - 550}{1260} = \frac{710}{1260} = 0.563$$

(b) Using equation (1), Art. 27, we have

$$\begin{aligned} \text{Efficiency} &= \frac{R(T_1 - T_2) \log_e r}{RT_1 \log_e r + (1 - e)C_p(T_1 - T_2)} \\ &= \frac{0.0684 \times 710 \times 0.6931}{0.0684 \times 1260 \times 0.6931 + 0.1 \times 0.1691 \times 710} \\ &= \frac{33.67}{59.74 + 12.00} = \frac{33.67}{71.74} = 0.469 \end{aligned}$$

The following example may be interesting to the reader, as the data is taken from the particulars of the air engines of the "Ericsson."

EXAMPLE 2.—In the Ericsson engines the temperature limits were 122°F. and 414°F. Piston displacement per pound of air = 22 cubic feet, ratio of expansion 1.5. Revs. per minute 9. Diameters of cylinders = 14 feet, stroke 6 feet. Calculate: (1) Work done per lb. of air per stroke; (2) thermal efficiency of engines (assuming efficiency of regenerator = 0.9); (3) mean effective pressure; (4) indicated horse-power.

$$\text{Here } T_1 = 414 + 460 = 874$$

(1) Work done per lb. of air per stroke = $R \log_e r (T_1 - T_2)$.

$$\text{Now } R = 0.0684 \text{ B.Th.U. per lb. (Ex. 1)} = 53.2 \text{ ft.-lbs. per lb.}$$

$$\begin{aligned} \therefore \text{Work done} &= 53.2 \times 0.4055 \times (414 - 122) \\ &= 6300 \text{ ft.-lbs.} \end{aligned}$$

(2) Heat supplied = $RT_1 \log_e r + (1 - e)C_p(T_1 - T_2)$ (Art. 28).

Substituting we get

$$\begin{aligned} \text{Heat supplied} &= 53.2 \times 874 \times 0.4055 + 0.1 \times 184.8 \times 292 \\ &= 18,860 + 5396 \\ &= 24,256 \text{ ft.-lbs.} \end{aligned}$$

Of the above quantity of heat, notice that due to the regenerator not being perfect the heat wasted by it is 5396 ft.-lbs.

$$\text{Hence efficiency} = \frac{6300}{24,256} = 0.255$$

Note.—If the efficiency of regenerator is unity the

$$\text{efficiency} = \frac{292}{874} = 0.33 \text{ or } \frac{6300}{18,860} = 0.33$$

$$\begin{aligned} (3) \text{ Mean effective pressure} &= \frac{\text{work done per lb. per stroke}}{\text{volume swept through by piston}} \\ &= \frac{6300}{22} \\ &= 286 \text{ lbs. per sq. ft.} \\ &= 2 \text{ lbs. per sq. inch (approx.).} \end{aligned}$$

$$(4) \text{ Area of each cylinder} = 0.7854 \times 14^2 = 154 \text{ sq. ft.}$$

$$\therefore \text{ Joint area of the four pistons} = 154 \times 4$$

$$\therefore \text{ Work done per minute} = 286 \times 154 \times 4 \times 6 \times 9 \text{ ft.-lbs.}$$

$$\begin{aligned} \therefore \text{ Indicated horse-power} &= \frac{286 \times 154 \times 4 \times 6 \times 9}{33,000} \\ &= 288 \text{ I.H.P.} \end{aligned}$$

EXAMPLE 3.—If a perfect air engine works on the Carnot cycle between temperature limits of 600° F. and 60° F., calculate its efficiency, and the ratio of the adiabatic expansion.

$$\text{Here } T_1 = 600 + 460 = 1060$$

$$T_2 = 60 + 460 = 520$$

$$\therefore \text{Efficiency} = \frac{540}{1060} = 0.509$$

Now for adiabatic expansion

$$\frac{T_2}{T_1} = \left(\frac{v_1}{v_2}\right)^{\gamma-1} \quad (\text{Art. 11, equation (4)})$$

$$\therefore \frac{520}{1060} = \left(\frac{1}{r}\right)^{0.4}$$

$$\begin{aligned} -0.4 \log r &= \log 520 - \log 1060 \\ &= 2.7160 - 3.0253 \\ &= -0.3093 \end{aligned}$$

$$\therefore \log r = \frac{0.3093}{0.4} = 0.7732 = \log 5.93.$$

therefore ratio of adiabatic expansion = 5.93.

EXAMPLE 4.—An air engine works on an ideal cycle in which heat is received at constant pressure and rejected at constant volume. The pressure at the end of the suction stroke is 14 pounds per square inch absolute, the ratio of compression is 15.3, and the ratio of expansion 7.5. If the expansion and compression curves are given by $p v^{1.4} = \text{constant}$, find the mean pressure for the cycle.

A sketch of the indicator diagram is shown in Fig. 14, the work done per cycle being represented by the shaded area. Let the volume at a be 1 cubic foot, then the volume at c and d is 15.3 cubic feet, and

$$p_a = p_d \times \left(\frac{15.3}{1}\right)^{1.4} = 14 \times (15.3)^{1.4} = 637.8 \text{ pounds per square inch.}$$

Since the ratio of expansion $\frac{v_c}{v_b}$ is 7.5, the volume at b is $\frac{15.3}{7.5} = 2.04$ cubic feet, and

$$\begin{aligned} p_a &= p_b \times \left(\frac{1}{7.5}\right)^{1.4} \\ &= 637.8 \times \left(\frac{1}{7.5}\right)^{1.4} = 38 \text{ pounds per square inch} \end{aligned}$$

Now work done during the cycle = shaded area

$$\begin{aligned} &= \text{area } fabg + \text{area } gbce - \text{area } fade \\ &= 144 \times 637.8 \times 1.04 + \frac{144}{1.4 - 1} (637.8 \times 2.04 - 38 \times 15.3) \\ &\quad - \frac{144}{1.4 - 1} (637.8 \times 1 - 14 \times 15.3) \\ &= 95,472 + 259,200 - 152,496 \\ &= 202,176 \text{ foot-pounds.} \end{aligned}$$

$$\begin{aligned} \text{Mean pressure} &= \frac{\text{work done in foot-pounds}}{\text{stroke volume in cubic feet}} \\ &= \frac{202,176}{14.3} = 14,138 \text{ pounds per square foot} \\ &= 98.1 \text{ pounds per square inch.} \end{aligned}$$

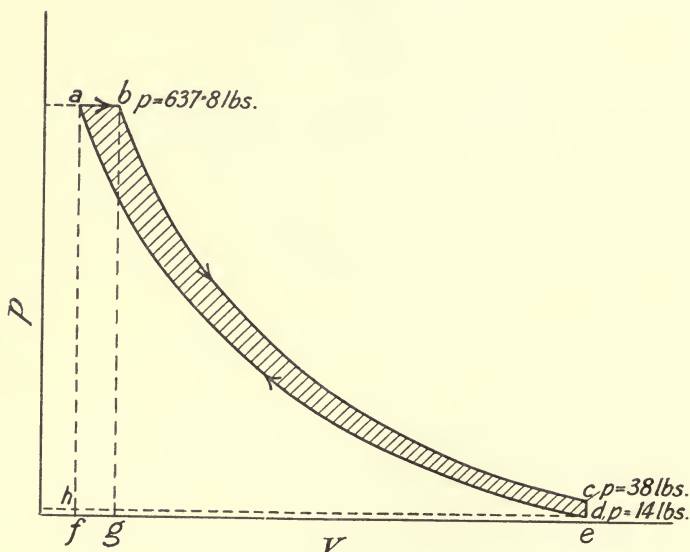

FIG. 14.

EXAMPLE 5.—If in Example 4 the temperature at the end of the suction stroke is 60°F ., estimate the efficiency. [$C_p = 0.2375$, $C_v = 0.1691$.]

$$\begin{aligned} T_a &= T_d \times \left(\frac{v_d}{v_a}\right)^{\gamma-1} \\ &= 520 \times (15.3)^{0.4} = 1548^{\circ} \text{ absolute} \end{aligned}$$

And for a perfect gas

$$\begin{aligned} \frac{p_a v_a}{T_a} &= \frac{p_b v_b}{T_b} \\ \therefore T_b &= T_a \times \frac{v_b}{v_a} \text{ since } p_a = p_b \\ &= 1548 \times \frac{2.04}{1} = 3158^{\circ} \text{ absolute.} \end{aligned}$$

Also

$$\begin{aligned} T_b &= T_c \times \left(\frac{v_c}{v_b}\right)^{\gamma-1} \\ T_c &= T_b \times \left(\frac{v_b}{v_c}\right)^{\gamma-1} \\ &= 3,158 \times \left(\frac{1}{7.5}\right)^{0.4} = 1410^{\circ} \text{ absolute.} \end{aligned}$$

Heat supplied per pound of air

$$= C_p(T_b - T_a) \\ = 0.2375(3158 - 1548) = 382.37 \text{ B.Th.U.}$$

Heat rejected per pound of air

$$= C_v(T_c - T_d) \\ = 0.1691(1,410 - 520) = 150.5 \text{ B.Th.U.}$$

$$\text{Efficiency} = \frac{\text{heat supplied} - \text{heat rejected}}{\text{heat supplied}} \\ = \frac{382.37 - 150.5}{382.37} \\ = 0.606 \text{ or } 60.6 \text{ per cent.}$$

The engine working on this cycle has been developed, not as an air engine, but as the Diesel oil engine (see Art. 194).

EXAMPLES II

1. In a Stirling air engine working between temperatures of 700°F. and 80°F. , the ratio of isothermal expansion is 2. Calculate the ideal efficiency when (a) the engine is fitted with a perfect regenerator; (b) when the efficiency of the regenerator is 0.9. Take $C_p = 0.2375$ and $C_v = 0.1691$.

2. Compare the efficiencies of: (a) A Stirling engine with perfect regenerator in which the maximum pressure is 140 lbs. per square inch absolute and minimum pressure 15 lbs. per square inch absolute, and limits of temperature 750°F. and 70°F. ; and (b) a perfectly reversible steam engine working between the same limits of pressure.

3. If a perfect air-engine works on the Carnot cycle between limits of temperature 780°F. and 50°F. , estimate its efficiency at the ratio of adiabatic expansion.

4. In a Joule air engine the maximum temperature is 600°F. and the initial pressure 180 lbs. per square inch. If the ratio of expansion be 3, calculate its efficiency.

5. What will be the efficiency of the engine in question (1) if no regenerator is fitted?

6. A Stirling engine, with perfect regenerator, works between pressures of 135 pounds per square inch absolute, and 15 pounds per square inch absolute, and temperatures 550°F. and 50°F. respectively. Calculate the mean effective pressure on the piston.

7. An air engine works on an ideal cycle in which heat is received at constant pressure, and rejected at constant volume. The pressure at the end of the suction stroke is 14 lbs. per square inch absolute, and temperature 40°C. The ratio of compression is 13 and the ratio of expansion 6.5. If the expansion and compression curves are adiabatic $p v^{1.2} = \text{constant}$, find the mean pressure for the cycle and its efficiency.

8. An ideal air engine works on the following cycle: air is taken in at atmospheric pressure 14.7 pounds per square inch and at temperature 55°F. , and is then compressed adiabatically so that at the end of the stroke the pressure is 550 pounds per square inch absolute. Heat is then taken in at constant pressure and then the air expands adiabatically, the ratio of expansion being 5. The air is exhausted at the end of the expansion stroke, the heat being rejected at constant volume. Estimate the efficiency. (Take $C_p = 0.2375$ and $C_v = 0.1691$.)

CHAPTER III

PROPERTIES OF STEAM

30. Generation of Steam under Constant Pressure.—This is the process which takes place in a steam boiler when its engine is working, the steam being withdrawn at the same rate as it is generated. Suppose we have 1 pound of water at a temperature of t_0° F., and occupying a volume of V_w cubic feet, to which heat is applied, then the following operations will result:—

(1) The temperature of the water will rise to some temperature t° F., at which steam will commence to form. The value of t will depend upon the pressure (which remains constant throughout) to which the water is subjected. The quantity of heat so supplied is called the *sensible heat*. If the specific heat of water be assumed constant and equal to unity the sensible heat added will be

$$t - t_0 \text{ B.Th.U.}$$

The specific heat, however, is not quite constant,¹ but the variation is so small that for practical purposes it may be neglected, at any rate the specific heat of water may be assumed equal to unity for approximate calculations.

(2) If the application of heat be continued, steam will be formed at a constant temperature t° F. until all the water has been evaporated. During this stage when the steam is formed in contact with the water the steam is said to be *saturated*. When all the original pound of water has been turned into steam, the heat supplied during evaporation is called the *latent heat* of the steam at the particular temperature t° , the steam being called *dry saturated steam*.

(3) If more heat be added to the dry saturated steam its temperature will rise to, say, t_1° F. The quantity of heat so added is sensible heat, and will be approximately equal to

$$C_p(t_1 - t) \text{ B.Th.U.}$$

where C_p is the mean specific heat of the steam at constant pressure.

Steam may therefore exist either as saturated steam, which may be either *dry* or *wet*, or as superheated steam. The temperature t° corresponding to the particular pressure at which the steam is formed is known as the *temperature of saturation*. Superheated steam which is well above the temperature of saturation approaches in properties to a perfect gas, and was called by Rankine *steam gas*.

¹ See "Steam Tables," by Marks and Davis, Longmans, Green & Co.

31. Relation between Pressure and Temperature of Saturated Steam.—There is no simple law connecting pressure and temperature. The classical experiments on this subject were carried out by Regnault in the year 1847, as a result of which he gave the law—

$$p = \left(\frac{t + 40}{147} \right)^5 \dots \dots \dots (1)$$

where p = absolute pressure in pounds per square inch.
and t = temperature in degrees Fahrenheit.

Rankine expressed the relation by the formula—

$$\log p = 6.1007 - \frac{2732}{T} - \frac{396,945}{T^2} \dots \dots \dots (2)$$

where p = absolute pressure in pounds per square inch,
and T = absolute temperature on the Fahrenheit scale.

In 1908, Thiesen expressed the relation by the formula—

$$(t + 459.6) \log \frac{p}{14.70} = 5.409(t - 212) - 3.71 \times 10^{-10} \{ (689 - t)^4 - 477^4 \} (3)$$

where p = absolute pressure in pounds per square inch,
and t = temperature in ordinary Fahrenheit degrees.

32. Relation between Pressure and Volume of Dry Saturated Steam.—The volume of 1 pound of dry saturated steam at any assigned pressure is a quantity known as the *specific volume*, and is extremely difficult to measure by direct experiment. It may, however, be calculated as follows:—

Consider a perfect heat engine using steam as the working fluid between limits of temperature T_1 and T_2 , and working on the Carnot cycle. The indicator diagram is shown in Fig. 15. The heat taken in per pound of steam is its latent heat L , and since the efficiency is $\frac{T_1 - T_2}{T_1}$ (Art. 21) the area of the diagram, or the work done per pound will be

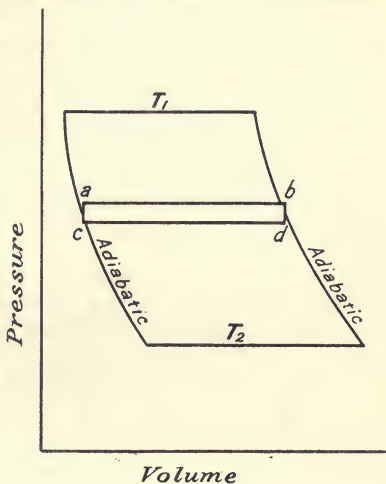

FIG. 15.

$$L \cdot \frac{T_1 - T_2}{T_1} \text{ B.Th.U., or } JL \cdot \frac{T_1 - T_2}{T_1} \text{ foot-pounds } \dots (1)$$

Suppose now, that the temperature range is very small, say from T to $T - \delta T$, the fall in temperature being a small amount δT , and the corresponding fall in pressure being a small amount δp . The indicator diagram will now be represented by the narrow strip $abdc$ in which

- length of diagram $ab = V_s - V_w$, and
- height of diagram $bd = \delta p$

Hence the area $abcd$ on the work done will be

$$\delta p(V_s - V_w) \dots \dots \dots (1)$$

But by (1) the work done is also equal to

$$JL \frac{\delta T}{T}$$

equating (1) and (2) we get

$$\begin{aligned} \delta p(V_s - V_w) &= JL \frac{\delta T}{T} \\ V_s &= V_w + \frac{JL}{T} \cdot \frac{\delta T}{\delta p} \dots \dots \dots (3) \end{aligned}$$

This is approximately correct when δT , and therefore δp , are small finite quantities. If now δT be diminished indefinitely the limiting value of (3) becomes

$$V_s = V_w + \frac{JL}{T} \cdot \frac{dT}{dp} \dots \dots \dots (4)$$

in which V_s = volume of 1 pound of dry saturated steam in cubic feet at absolute temperature T .

V_w = volume of 1 pound of water in cubic feet.

The value of $\frac{dT}{dp}$ is obtained from the temperature-pressure curve, being the tangent to the curve at the particular temperature and pressure under consideration. The student will find it instructive to plot the temperature-pressure curve from the steam tables given on page 480, and from that curve work out the volume of 1 pound of dry saturated steam at a few different pressures, comparing his calculated volumes with the volumes tabulated there.

Equation (4) may also be used to find the change in the freezing-point of water due to change in pressure. The following example will illustrate this—

It is known that 1 pound of water at 32° F. changes in volume from 0.016 cubic foot to 0.0174 cubic foot on solidifying, and gives out its latent heat 144 B.Th.U., and from (4)

$$\frac{dT}{dp} = (V - w) \frac{T}{JL}$$

where V = volume of 1 pound of ice in cubic feet at 32° F., or 493° absolute and w = " " water " " " "

$$\therefore \frac{dT}{dp} = \frac{(0.0174 - 0.016)493}{778 \times 144} = 0.0000065$$

Hence at atmospheric pressure when $dp = 2116$ pounds per square foot

$$\begin{aligned} dT &= 2116 \times 0.0000065 \\ &= 0.0135^\circ \text{ F.} \end{aligned}$$

i.e. the freezing-point of water changes 0.0135° F. for every atmosphere change in pressure, so that at a pressure of 11 atmospheres the freezing-point would be 32.135° F.

33. Total Heat of Evaporation of Saturated Steam.—The total heat H of 1 pound of saturated steam is always reckoned from 32° F. For stages (1) and (2), Art. 30, we have

total heat $H =$ sensible heat $+$ latent heat

$$H = h + L \dots \dots \dots (1)$$

For steam at a temperature t° F. this becomes approximately

$$H = (t - 32) + L$$

The values of H found by Regnault may be approximately expressed by the equation

$$H = 1082 + 0.3t \text{ B.Th.U.} \dots \dots \dots (2)$$

A more accurate value for the total heat of evaporation of dry saturated steam is

$$H = 1150.3 + 0.3745(t - 212) - 0.00055(t - 212)^2 \text{ B.Th.U.}^1 \quad (3)$$

If the temperature is measured in $^{\circ}$ C., the value of H according to Regnault may be approximately written

$$H = 607 + 0.3t \text{ C.H.U.} \dots \dots \dots (4)$$

The above equations only refer to dry saturated steam. If the steam is wet, the quantity of heat supplied during the formation of the steam will not be equal to the latent heat L because all the water will not have been evaporated. Suppose 1 pound of the wet steam contains x pound of steam, the remainder $(1 - x)$ being water mechanically suspended in it; then x is called the *dryness fraction* of the steam, and

$$H' = h + xL \dots \dots \dots (5)$$

34. External Work done during Evaporation at Constant Pressure.—Let P be the absolute pressure, in pounds per square foot, at which the steam is generated, the volume will change during evaporation from that of 1 pound of water (V_w) to that of 1 pound of dry saturated steam (V_s), and the external work done will be

Pressure (pounds per square foot) \times change in volume (cubic feet)

$$\text{i.e. } E = P(V_s - V_w) \text{ foot-pounds, or}$$

$$\frac{P}{J}(V_s - V_w) \text{ heat units.}$$

If the external work is required in B.Th.U. the value of J is 778; if J be taken as 1400 the result will be in C.H.U.

35. Internal Energy of Steam.—When steam is generated at constant pressure, the heat of evaporation as defined in Art. 33 is *not* the total heat the steam possesses. During evaporation external work has to be done of amount $\frac{P}{J}(V_s - V_w)$ heat units, and of the latent heat L , supplied, this quantity is not found in the steam; the difference is known as the internal latent heat, and is usually denoted by ρ . The internal latent heat may therefore be written

Latent heat — external work done during evaporation

$$\rho = L - \frac{P}{J}(V_s - V_w) \dots \dots \dots (1)$$

¹ Marks and Davis, "Steam Tables."

The *internal* or *intrinsic* energy of steam is the name given to the sum of the internal latent heat, and the sensible heat of the water

$$\begin{aligned} \text{i.e. internal or intrinsic energy (I)} &= \rho + h \quad \dots \quad (2) \\ \text{or } I &= H - E \quad \dots \quad (2A) \end{aligned}$$

The total heat of evaporation may therefore be written

$$\begin{aligned} H &= h + L \\ \text{or } H &= h + \rho + E \quad \dots \quad (3) \end{aligned}$$

The latent heat of steam varies with the temperature at which it is produced, and for practical calculations, when steam tables are not available, it may be estimated from the approximate formula

$$L = 1114 - 0.7t \text{ B.Th.U.} \quad \dots \quad (4)$$

where t is the temperature of saturation in °F.

$$\text{or } L = 1437 - 0.7T \quad \dots \quad (4A)$$

where T is the absolute temperature of the steam, *i.e.* $t + 460$.

The total heat of dry saturated steam may therefore be approximately expressed as

$$\begin{aligned} H &= h + L \\ &= (t - 32) + 1114 - 0.7t \\ &= 1082 + 0.3t \text{ B.Th.U. per pound} \quad \dots \quad (5) \end{aligned}$$

a result already given in Art. 33.

It will be observed from equation (4) that the latent heat *decreases* as the temperature (and therefore the pressure) increases, but from (5) the total heat always *increases* as the temperature (and therefore the pressure) increases.

If the temperature is measured in °C. the approximate formula for latent heat becomes

$$L = 607 - 0.7t \text{ C.H.U.} \quad \dots \quad (6)$$

where t is the temperature of saturation in °C.

The total heat of dry saturated steam may therefore be approximately expressed as

$$\begin{aligned} H &= h + L \\ &= t + 607 - 0.7t \\ &= 607 + 0.3t \text{ C.H.U. per pound} \quad \dots \quad (7) \end{aligned}$$

36. Specific Volume and Internal Energy of Wet Steam.—

The specific volume, or volume of 1 pound, of wet steam will be less than that of dry steam at the same pressure because of the difference between the densities of the steam and the water it contains.

Let V_{ws} be the volume of 1 pound of wet steam in cubic feet, then, using the same notation as before

$$\begin{aligned} V_{ws} &= (\text{volume of dry steam} + \text{volume of water}) \text{ in 1 pound of the mixture} \\ &= xV_g + (1 - x)V_w \quad \dots \quad (1) \end{aligned}$$

or neglecting the volume of the water $(1 - x)V_w$,

$$V_{ws} = xV_g \text{ approximately} \quad \dots \quad (2)$$

The external work done during the formation of 1 pound of wet steam at constant pressure will be

$$E' = \text{pressure per square foot} \times \text{change in volume (cubic feet)}$$

$$E' = P\{xV_s + (1 - x)V_w - V_w\} \text{ foot-pounds}$$

$$= P(xV_s - xV_w) \text{ foot-pounds} \dots \dots \dots (3)$$

$$\text{or } E' = \frac{Px}{J}(V_s - V_w) \text{ heat units} \dots \dots \dots (4)$$

Now the total heat of evaporation is by (1) Art. 33

$$H' = h + xL$$

therefore the internal, or intrinsic energy, is

$$I' = H - E'$$

$$= h + xL - \frac{Px}{J}(V_s - V_w) \text{ heat units} \dots \dots (5)$$

37. Superheated Steam.—The specific heat of steam at constant pressure (C_p) was first determined by Regnault, who only worked with steam at atmospheric pressure. The figure he obtained was 0.4805. Since then, an enormous amount of research has been carried out, having for its object the determination of the specific heat at various pressures. The results obtained may be briefly summed up as follows:—

(1) The mean value of 0.4805 obtained originally by Regnault is only true for steam at atmospheric pressure, that pressure being the only one he used in his experiments.

(2) The specific heat is a function of both the pressure and the temperature.

(3) The value of C_p increases with the pressure but decreases as the temperature rises.

In the neighbourhood of atmospheric pressure recent researches confirm Regnault's value 0.48; at 100 pounds per square inch absolute and at the temperature of saturation corresponding to this pressure, the value appears to be about 0.57, falling to 0.48 at a temperature of about 700° F. At the temperature of saturation, corresponding to a pressure of 200 pounds per square inch absolute, $C_p = 0.7$ falling to 0.49 at a temperature of 700° F.

Complete curves showing the variation of C_p with pressure and temperature will be found in Marks and Davis' "Steam Tables."

Total Heat of Superheated Steam.—The total heat of 1 pound of superheated steam will be the heat of evaporation per pound of dry saturated steam, plus the additional quantity of heat supplied during superheating. This latter quantity will be a function of the temperature, and may be expressed as

$$\int_{t_1}^{t_1} C_p dT$$

where t_1 = the temperature of saturation

and t_1 = the temperature of the superheated steam

The total heat may therefore be written as follows:—

$$H = h + L + \int_{t_1}^{t_1} C_p dT \text{ heat units} \dots \dots (1)$$

For purely academic problems we may assume C_p to be constant, the expression for total heat under this assumption being

$$H = h + L + C_p(t_1 - t) \text{ heat units} \quad \dots \quad (2)$$

If the temperatures are measured on the Centigrade scale, H will be in C.H.U.; if on the Fahrenheit scale, H will be in B.Th.U.

38. Throttling or Wire-drawing of Steam.—If wet steam be allowed to expand freely *without doing work*, its final and initial velocities being equal, and without receiving or rejecting heat, it will become drier; if the steam be dry to commence with it will become superheated after the expansion. Free unresisted expansion of this nature may be called expansion at constant heat (since there is no interchange of heat), and the steam is said to be wire-drawn or throttled.

Let p_1 = initial pressure of the steam before throttling.

p_2 = final pressure of the steam after throttling.

H_1 = total heat of the saturated steam per pound at pressure p_1 .

H_2 = total heat of saturated steam of the same quality per pound at pressure p_2 .

Then H_1 is greater than H_2 , and since no heat is supplied or taken away during the unresisted expansion, it follows that for each pound of steam ($H_1 - H_2$) heat units are available for drying the steam if it were originally wet, or for superheating the steam if it were originally dry; and further, if ($H_1 - H_2$) heat units are more than necessary to completely dry the steam, the excess will be available for superheating.

If the steam be wet after throttling we have, per pound,

Heat before throttling = heat after throttling

$$h_1 + x_1 L_1 = h_2 + x_2 L_2$$

where the suffixes 1 and 2 refer to the condition of the steam before and after throttling respectively.

EXAMPLE I.—Calculate the total heat of evaporation, and the internal energy of 1 pound of saturated steam at a pressure of 100 pounds per square inch absolute, (a) when the steam is dry, and (b) when the dryness fraction of the steam is 0.8. Given temperature of saturation 328°F. , and the specific volume of dry saturated steam at this pressure and temperature 4.229 cubic feet.

$$\begin{aligned} \text{Latent heat at } 328^\circ \text{F.} &= 1114 - 0.7 \times 328 \\ &= 1114 - 229.6 = 884.4 \text{ B.Th.U.} \end{aligned}$$

$$\begin{aligned} (a) \quad \text{Total heat } H &= h + L \\ &= (328 - 32) + 884.4 \\ &= 1180.4 \text{ B.Th.U.} \end{aligned}$$

From Art. 34

$$\text{External work done } E = \frac{P}{J} (V_s - V_w).$$

Here $P = 144 \times 100$ pounds per square foot, and the volume of 1 pound of water (V_w) is 0.016 cubic foot, hence

$$\begin{aligned} E &= \frac{144 \times 100}{778} (4.229 - 0.016) \\ &= \frac{144 \times 100}{778} \times 4.213 \\ &= 77.9 \text{ B.Th.U.} \end{aligned}$$

$$\therefore \text{Internal energy } I = H - E \quad (\text{Art. 35 (2A)})$$

$$\begin{aligned} &= 1180.4 - 77.9 \\ &= 1002.5 \text{ B.Th.U.} \end{aligned}$$

$$\begin{aligned} (b) \quad H &= h + xL \\ &= (328 - 32) + 0.8 \times 884.4 \\ &= 296 + 707.5 \\ &= 1003.5 \text{ B.Th.U.} \end{aligned}$$

From (4) Art. 36

$$\begin{aligned} \text{External work done } E &= \frac{P \cdot x}{J} (V_s - V_w) \\ &= \frac{144 \times 100 \times 0.8}{778} \times 4.213 \\ &= 62.3 \text{ B.Th.U.} \end{aligned}$$

$$\begin{aligned} \text{Internal energy } I &= H - E \\ &= 1003.5 - 62.3 \\ &= 941.2 \text{ B.Th.U.} \end{aligned}$$

EXAMPLE 2.—In a steam boiler 9.5 pounds of steam are generated per pound of coal burned. The boiler pressure is 155.3 pounds per square inch gauge and the temperature of the feed water is 90° F. If the dryness fraction of the steam is 0.98, and the calorific value of the coal is 14,500 B.Th.U. per pound, calculate the efficiency of the boiler.

$$\begin{aligned} \text{Here the absolute steam pressure} &= 155.3 + 14.7 \\ &= 170 \text{ pounds per square inch.} \end{aligned}$$

From "Steam Tables" (p. 481) we find that at this pressure,

$$h = 340.7 \text{ and } L = 854.7$$

$$\begin{aligned} \text{hence, total heat of evaporation per pound } H_1 &= h + xL \\ &= 340.7 + 0.98 \times 854.7 \\ &= 340.7 + 837.6 \\ &= 1188.3 \text{ B.Th.U.} \end{aligned}$$

But the feed temperature is 90° F., therefore each pound of water contains 90 — 32 or 58 B.Th.U. when fed into the boiler, hence

$$\begin{aligned} \text{Heat supplied by the boiler per pound of steam} &= 1188.3 - 58 \\ &= 1130.3 \text{ B.Th.U.} \end{aligned}$$

$$\begin{aligned} \text{Efficiency of boiler} &= \frac{1130.3 \times 9.5}{14,500} \\ &= 0.7405 \text{ or } 74.05 \text{ per cent.} \end{aligned}$$

EXAMPLE 3.—Measurements from an indicator diagram taken on a steam engine show that at a certain instant during expansion the volume

of the steam is 1.15 cubic feet and the pressure 50 pounds per square inch absolute. If the weight of steam in the cylinder is 0.15 pound what is the quality of the steam at that instant?

From "Steam Tables" we see that at a pressure of 50 pounds the volume of 1 pound of dry saturated steam is 8.51 cubic feet. If, therefore, the steam in the cylinder were dry its volume would be

$$0.15 \times 8.51 = 1.27 \text{ cubic foot.}$$

Hence, neglecting the volume of the water in the steam

$$\text{Dryness fraction} = \frac{1.15}{1.27} = 0.88$$

EXAMPLE 4.—A vessel of 3 cubic feet capacity is full of steam at a pressure of 20 pounds per square inch absolute and of dryness fraction 0.8. It is coupled up to a steam pipe in which steam of dryness 0.9 is at a pressure of 190 pounds per square inch. Steam is admitted into the vessel from the pipe until the pressure in the vessel is 190 pounds absolute. Find the weight of steam admitted and the final dryness fraction of the mixture. Given

Pressure.	h	L	Specific volume.
20	196.1	960.0	20.08
190	350.4	846.9	2.40

We must first find the weight of steam in the vessel at a pressure of 20 pounds per square inch, as follows:—

Neglecting the volume of the water in the steam, we have—

Volume of 1 lb. of dryness fraction 0.8 = $20.08 \times 0.8 = 16.064$ cubic feet

Actual volume of steam = 3 cubic feet

$$\therefore \text{weight of steam} = \frac{3}{16.064} = 0.1868 \text{ pound}$$

Let W = weight of steam admitted in pounds
and x = final dryness fraction of the mixture.

Then the total heat of 0.1868 pound of steam at 20 pounds pressure, and W pounds at 190 pounds pressure before admission into the vessel is

$$0.1868(196.1 + 0.8 \times 960) + W(350.4 + 0.9 \times 846.9) \text{ B.Th.U.}$$

$$= 0.1868(196.1 + 768) + W(350.4 + 762.2) \text{ B.Th.U.}$$

After mixing the total heat contents in the vessel will be—

$$(W + 0.1868)(350.4 + x \times 846.9) \text{ B.Th.U.}$$

Assuming no loss of heat to take place during the mixing and neglecting the thermal capacity of the vessel, these two quantities will be equal,

$$\therefore (W + 0.1868)(350.4 + x \times 846.9) = 0.1868 \times 964.1 + W \times 1112.6 \quad (1)$$

In equation (1) there are two unknowns, x and W , we must therefore find another equation connecting them.

If the final contents of the vessel were dry saturated the volume would be

$$(W + 0.1868)2.4 \text{ cubic feet.}$$

The volume actually occupied is 3 cubic feet. Hence neglecting the volume of the water present,

$$x = \frac{3}{2.4(W + 0.1868)} \quad \dots \quad (2)$$

(2) in (1) gives

$$(W + 0.1868) \left(350.4 + \frac{3 \times 846.9}{2.4(W + 0.1868)} \right) = 0.1868 \times 964.1 + W \times 1112.6$$

$$350.4W + 65.45 + \frac{3 \times 846.9}{2.4} = 180.09 + 1112.6W$$

$$350.4W + 65.45 + 1058.6 = 180.09 + 1112.6W$$

$$762.2W = 943.96$$

$$W = 1.238 \text{ pounds.}$$

Substituting this value of W in (2) gives

$$x = \frac{3}{2.4(1.238 + 0.1868)} \\ = 0.877.$$

EXAMPLE 5.—Boiler steam of dryness 0.97 and at 340 pounds per square inch absolute ($t = 429^\circ \text{ F.}$) is wiredrawn to 200 pounds per square inch absolute ($t = 382^\circ \text{ F.}$). Find the dryness fraction on the engine side of the reducing valve.

Solving this problem without the use of "Steam Tables" we have—

$$\text{Latent heat at } 429^\circ \text{ F.} = 1114 - 0.7 \times 429 = 814 \text{ B.Th.U.}$$

$$\text{Latent heat at } 382^\circ \text{ F.} = 1114 - 0.7 \times 382 = 847 \text{ B.Th.U.}$$

Let x_2 = dryness fraction after wiredrawing, then

$$h_1 + x_1 L_1 = h_2 + x_2 L_2$$

$$(429 - 32) + (0.97 \times 814) = (382 - 32) + x_2 \times 847$$

$$397 + 789.6 = 350 + 847x_2$$

$$847x_2 = 836.6$$

$$x_2 = 0.987$$

39. Measurement of the Dryness of Steam.—There are several methods in use for determining the dryness fraction of steam, some of which are more accurate than others. The greatest uncertainty experienced, in all cases, is the extreme difficulty of obtaining a representative sample of the steam to be tested (see Art. 209).

The simplest method is to blow a certain weight of steam into a known weight of water, and measure the rise in temperature produced. Then by equating the heat lost by the steam to the heat gained by the water the dryness fraction can be calculated.

Let w = weight of steam condensed in pounds.

x = dryness fraction of the steam.

W = weight of water in pounds.

t_1 = initial temperature of the water in $^\circ \text{ F.}$

t_2 = final temperature of the water in $^\circ \text{ F.}$

W' = weight of vessel containing the water in pounds.

s = specific heat of the material of which the vessel is made.

Then, heat lost by steam = $w(xL + t - t_2)$ B.Th.U.

(where $t^\circ \text{ F.}$ is the temperature of the steam under test)

and heat gained by vessel and water = $(W + sW')(t_2 - t_1)$ B.Th.U.

Equating these two quantities we have

$$w(xL + t - t_2) = (W + sW')(t_2 - t_1) \quad \dots \quad (1)$$

an equation from which x may be calculated.

The above theory assumes that the specific heat of water is constant and equal to unity, which of course is not quite true. For all practical purposes, however, the error involved is negligible, particularly in comparison with the uncertainty of the sample of steam taken. If instead of t, t_1 and t_2 in (1) we write h, h_1 and h_2 , the sensible heats at these temperatures, we have

$$w(xL + h - h_2) = (W + sW')(h_2 - h_1) \quad \dots \quad (2)$$

an equation which is quite accurate.

Another method frequently employed is similar to the above, but the steam and water are not allowed to come into contact. The steam under test flows through a pipe (or series of tubes) around which water is circulating. The inlet and outlet temperatures of the water are measured, together with the weight of water flowing through the instrument in any convenient time and the weight of steam condensed in the same time. By equating the heat lost by the steam and the heat gained by the water the dryness fraction of the steam may be calculated.

Let w = weight of steam condensed in pounds per minute.

t' = temperature of condensed steam in ° F.

W = weight of cooling water in pounds per minute.

t = temperature of the steam in ° F.

t_1 = inlet temperature of cooling water in ° F.

t_2 = outlet temperature of cooling water in ° F.

Then, the heat lost by the steam = $w(xL + h - h')$ B.Th.U.

and heat gained by the water = $W(h_2 - h_1)$ B.Th.U.

$$\therefore w(xL + h - h') = W(h_2 - h_1) \quad \dots \quad (1)$$

or, neglecting the variation in the specific heat of water,

$$w(xL + t - t') = W(t_2 - t_1) \quad \dots \quad (2)$$

In Art. 38 it has been shown that steam becomes drier after throttling, and in certain cases, superheated. This principle has been utilised in the throttling calorimeter, first designed by Professor Peabody, which enables the dryness of steam to be conveniently and accurately measured.

40. Theory of the Throttling Calorimeter.—This calorimeter is an instrument for the experimental determination of the dryness of steam. Fig. 16 shows the arrangement. The pipe B is screwed into the main steam pipe A, and steam admitted through the valve C expands through a small hole into the calorimeter D. The thermometer E gives the temperature of the steam after the expansion, while the manometer F gives the pressure (above atmospheric) of the steam after expansion. From Art. 38 it will be seen that if the steam in the main pipe is nearly dry, after expansion it will be dried *and then superheated*, the amount of superheat being obtained from the reading of the thermometer E, and the temperature of saturation corresponding to the pressure after expansion.

Let t_3 = reading of thermometer E.

t_2 = temperature of saturation corresponding to pressure p_2 after expansion (obtained from steam tables).

h_1 = sensible heat at pressure p_1 before expansion.

L_1 = latent heat of steam at pressure p_1 .

Then if x = dryness fraction required

$$h_1 + xL_1 = H_2 + 0.48(t_3 - t_2) \dots \dots \dots (1)$$

From (1) x may be calculated.

In practice the values of h_1 , L_1 , H_2 , and t_2 will be taken from steam tables.

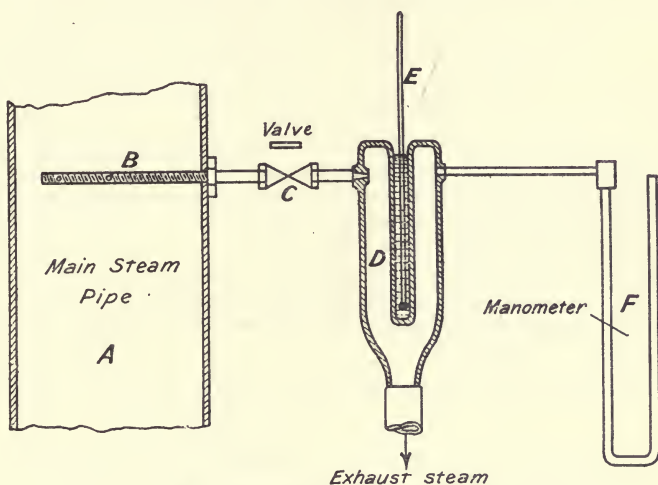

FIG. 16.—Throttling calorimeter.

Limitation of the Instrument.—The action of the calorimeter depends upon the fact that the steam after expansion is *superheated*. The calorimeter would be useless if the steam were so wet that after expansion it remains wet. The theoretical limit is obviously reached when after expansion the steam is just dry, and $t_3 = t_2$; this usually occurs when the dryness fraction is about 0.94 to 0.95. The calorimeter is very reliable for steam having a dryness fraction of about 0.98, and since any good modern steam boiler will give steam of this dryness, it is used almost universally for measuring the dryness of steam leaving a boiler. If the steam contains more than 5 per cent. of moisture (dryness fraction 0.95) its dryness may be measured as indicated in Art. 39, or by means of a separating calorimeter combined with a throttling calorimeter.

EXAMPLE 1.—In a test of a condensing plant the following data were obtained :—

- (a) Steam condensed per hour 1552 pounds.
- (b) Temperature of exhaust vapour entering condenser 104.7° F.
- (c) Circulating water per minute 476 pounds.
- (d) Temperature of circulating water as it enters the condenser 60° F.
- (e) Temperature of circulating water as it leaves the condenser 90° F.
- (f) Temperature of air pump discharge 95.5° F.

Calculate the dryness fraction of the exhaust steam as it enters the condenser.

$$L_{104.7} = 1114 - 0.7 \times 104.7 = 1114 - 72.3 = 1040.7 \text{ B.Th.U.}$$

$$\text{Heat lost by the steam per min.} = \frac{1552}{60} \{ (104.7 - 95.5) + (x \times 1040.7) \} \text{ B.Th.U.}$$

$$\text{Heat gained by the circulating water per minute} = 476 (90 - 60) \text{ B.Th.U.}$$

Assuming no loss of heat, the heat lost by the steam will be equal to the heat gained by the water, hence

$$\frac{1552}{60} \{ (104.7 - 95.5) + (x \times 1040.7) \} = 476(90 - 60)$$

$$1552(1040.7x + 9.2) = 476 \times 30 \times 60$$

$$1040.7x = 522.2 - 9.2$$

$$x = \frac{543}{1040.7} = 0.529 \text{ or } 52.9 \text{ per cent.}$$

EXAMPLE 2.—The following data were obtained from a test with a combined throttling and separating calorimeter: Water collected in separating calorimeter 4.5 pounds, steam condensed after leaving throttling calorimeter 45.5 pounds. Steam pressure in main steam pipe 150.3 pounds per square inch gauge, barometer 30 inches, temperature of steam in throttling calorimeter 290° F., reading of manometer 4 inches, estimate the dryness of the steam in the main steam pipe.

Separating Calorimeter.—The moisture extracted from 50 pounds of steam is 4.5 pounds; the remaining 45.5 pounds of steam which has thereby been partially dried is then passed through the throttling calorimeter.

Throttling Calorimeter.—

Absolute pressure of the steam admitted = gauge pressure + atmospheric pressure.

$$= 150.3 + 14.7.$$

$$= 165 \text{ pounds per square inch.}$$

Absolute pressure in calorimeter = 4 + 30 = 34 inches of mercury.

$$= 34 \times 0.49.$$

$$= 16.7 \text{ pounds per square inch.}$$

From steam tables we find—

$$\text{at } 165 \text{ pounds absolute, } h = 338.2, L = 856.8$$

$$\text{at } 16.7 \text{ pounds absolute, } H = 1152.7, t = 218.5^\circ \text{ F.}$$

Hence assuming the specific heat of steam to be 0.48,

$$h_1 + xL_1 = H_2 + 0.48(t_3 - t_2)$$

$$338.2 + x \times 856.8 = 1152.7 + 0.48(290 - 218.5)$$

$$= 1152.7 + 34.3$$

$$= 1187.0$$

$$856.8 x = 1187 - 338.2$$

$$x = \frac{848.8}{856.8}$$

$$= 0.990$$

or, in each pound of steam passing through the throttling calorimeter there is 0.01 pound of water, hence in 45.5 pounds there will be $45.5 \times 0.01 = 0.455$ pound of water.

∴ total water in the 50 pounds of steam = $4.5 + 0.455 = 4.955$ pounds.

and dryness fraction = $\frac{50 - 4.955}{50} = 0.900$ or 90%.

41. Entropy of Steam.—It has been shown in Art. 15, that when 1 pound of any substance is heated at constant pressure from temperature T_1 to temperature T_2 the gain of entropy is $C_p \log_e \frac{T_2}{T_1}$. If the substance be water, and we assume the specific heat C_p to be constant and equal to unity, this expression becomes

$$\text{Gain of entropy} = \log_e \frac{T_2}{T_1}$$

For convenience in practice it is usual to measure the entropy of water and steam from some arbitrary temperature, the temperature universally used being 32°F. or 0°C. The entropy of water at the above absolute temperature T will therefore be the change of entropy when 1 pound of water is heated from 492° (*i.e.* $32 + 460$) to T , and is written

$$\phi_w = \log_e \frac{T}{492} \dots \dots \dots (1)$$

If now the pound of water at temperature T be converted into dry saturated steam at the same temperature, the change of entropy during evaporation will be

$$\frac{L}{T} \dots \dots \dots (2)$$

The entropy of 1 pound of dry saturated steam at absolute temperature T will therefore be

$$\phi_s = \log_e \frac{T}{492} + \frac{L}{T} \dots \dots \dots (3)$$

or $\phi_s = \log_e \frac{T}{273} + \frac{L}{T}$ (where T and L are in Centigrade units) (4)

42. Entropy of Superheated Steam.—The increase of entropy during the superheating of steam at constant pressure is frequently calculated on the assumption that the specific heat is constant. On this assumption the gain of entropy during the superheating of dry saturated steam from temperature T to temperature T' will be

$$C_p \log_e \frac{T'}{T} \text{ (Art. 15)}$$

The entropy of 1 pound of superheated steam at absolute temperature T' will therefore be

$$\phi = \log_e \frac{T}{492} + \frac{L}{T} + C_p \log_e \frac{T'}{T} \dots \dots \dots (1)$$

The entropy given in steam tables is calculated by taking account of the variability of the specific heat of both water and steam, but for academic purposes, or in cases where steam tables are not available, equation (3), Art. 41, may be used for dry saturated steam, and (1) above for superheated steam.

EXAMPLE.—Calculate from first principles the entropy of 1 pound of water and 1 pound of steam at the following temperatures: 110°F. , 212°F. , 280°F. , 320°F. , and 366°F.

At 110°F. , the absolute temperature is $110 \times 461 = 571$.

$$\begin{aligned} \therefore \phi_w &= \log_{\epsilon} \frac{571}{493} = 2.3026 \log_{10} \frac{571}{493} \\ &= 2.3026 \times 0.0638 = 0.1469 \end{aligned}$$

Similarly we find

$$\begin{aligned} \text{at } 212^\circ \text{F. } \phi_w &= 2.3026 \log_{10} \frac{673}{493} = 2.3026 \times 0.1352 = 0.3113 \\ \text{,, } 280^\circ \text{F. } \phi_w &= 2.3026 \log_{10} \frac{744}{493} = 2.3026 \times 0.1788 = 0.4117 \\ \text{,, } 320^\circ \text{F. } \phi_w &= 2.3026 \log_{10} \frac{781}{493} = 2.3026 \times 0.1999 = 0.4606 \\ \text{,, } 366^\circ \text{F. } \phi_w &= 2.3026 \log_{10} \frac{826}{493} = 2.3026 \times 0.2242 = 0.5163 \end{aligned}$$

Now, gain of entropy during evaporation $= \frac{L}{T}$, hence we have

$$L_{110} = 1114 - 0.7 \times 110 = 1114 - 77 = 1037 \quad \therefore \frac{L}{T} = \frac{1037}{571} = 1.8161$$

$$L_{212} = 1114 - 0.7 \times 212 = 1114 - 148 = 966 \quad \therefore \frac{L}{T} = \frac{966}{673} = 1.4353$$

$$L_{280} = 1114 - 0.7 \times 280 = 1114 - 196 = 918 \quad \therefore \frac{L}{T} = \frac{918}{744} = 1.2338$$

$$L_{320} = 1114 - 0.7 \times 320 = 1114 - 224 = 890 \quad \therefore \frac{L}{T} = \frac{890}{781} = 1.1382$$

$$L_{366} = 1114 - 0.7 \times 366 = 1114 - 256 = 858 \quad \therefore \frac{L}{T} = \frac{858}{826} = 1.0384$$

Hence we have

$$\begin{aligned} \text{at } 110^\circ \text{F. } \phi_s &= 0.1469 + 1.8161 = 2.0230 \\ \text{,, } 212^\circ \text{F. } \phi_s &= 0.3113 + 1.4353 = 1.7466 \\ \text{,, } 280^\circ \text{F. } \phi_s &= 0.4117 + 1.2338 = 1.6455 \\ \text{,, } 320^\circ \text{F. } \phi_s &= 0.4606 + 1.1382 = 1.5988 \\ \text{,, } 366^\circ \text{F. } \phi_s &= 0.5163 + 1.0384 = 1.5447 \end{aligned}$$

43. Temperature-Entropy Diagram for Steam.—Draw the log-curve ob (Fig. 17) for 1 pound of water, according to the equation

$$\phi_w = \log_{\epsilon} \frac{T}{492}. \quad \text{Let the water be turned into steam at a temperature } T_1,$$

then the gain of entropy during evaporation is $\frac{L_1}{T_1}$ being represented by ae .

Similarly at any other temperature T_2 , the gain of entropy during evaporation is $\frac{L_2}{T_2}$ or bc . In this manner the *saturation curve* cd (Fig. 17) may be plotted. The two curves ob and cd must meet in some point where the latent heat is zero, which point will be at the critical temperature.

If the steam be now superheated to temperature T_3 , the change of entropy during superheating will be $0.48 \log_{\epsilon} \frac{T_3}{T_2}$ represented by ce (Fig. 18) if we assume the specific heat to be constant and equal to 0.48. If, therefore, from the point c in Fig. 17 we plot the curve $0.48 \log_{\epsilon} \frac{T}{T_2}$ we get the curve ce Fig. 18, which shows the change of entropy during superheating. The curve ce is called a constant pressure line because it represents the

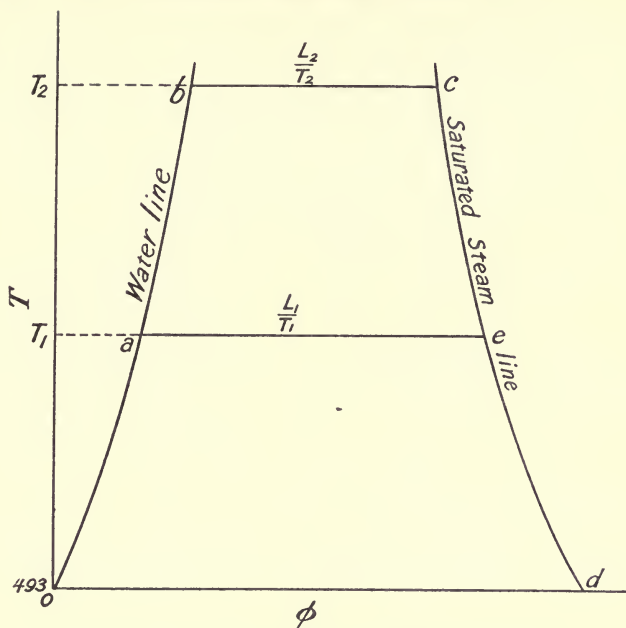

FIG. 17.—Curve of entropy for dry saturated steam.

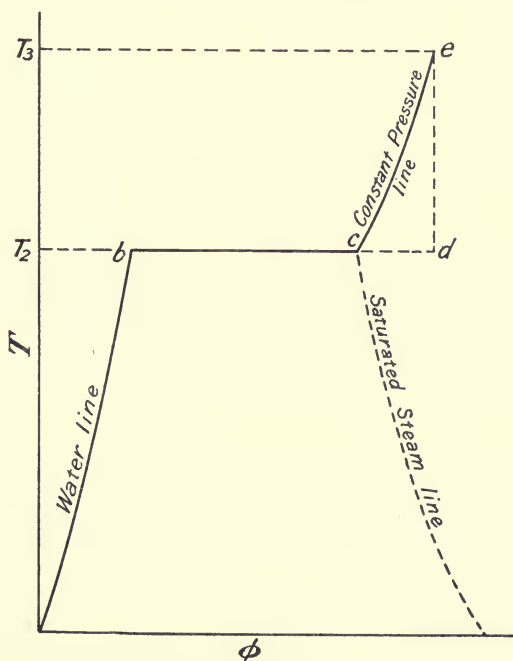

FIG. 18.—Curve of entropy for superheated steam.

entropy of superheated steam at the pressure corresponding to the temperature of saturation $T_2 - 460$.

44. Entropy of Wet Steam.—When 1 pound of wet steam is produced from water, the quantity of heat supplied is not equal to the latent heat of 1 pound of steam, because all of the steam is not evaporated. Let T be the temperature of the steam and x its dryness fraction, then the quantity of heat supplied during this partial evaporation will be—

$$xL$$

and the change of entropy will be

$$\frac{xL}{T}$$

where L denotes the latent heat of 1 pound of dry saturated steam at temperature T .

The total entropy ϕ_{ws} of 1 pound of the steam will therefore be

$$\phi_{ws} = \log_e \frac{T}{492} + \frac{xL}{T} \dots \dots \dots (1)$$

This will be represented on the temperature-entropy diagram by the point c (Fig. 19). Here $ab = \frac{L}{T}$, and $ac = \frac{xL}{T}$, and therefore

$$\frac{ac}{ab} = x$$

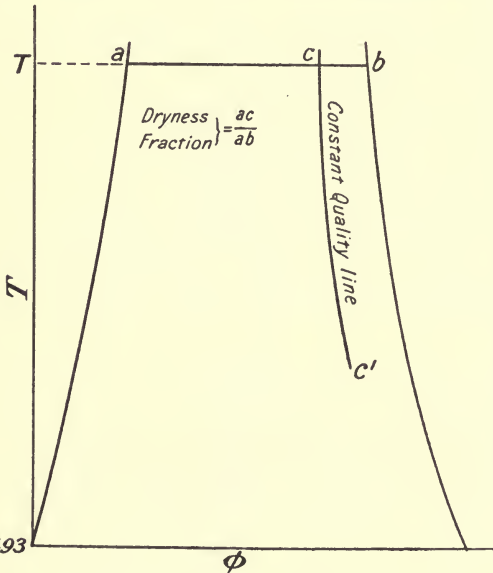

If now a number of isothermal lines on the diagram are divided in this constant ratio, and the points so obtained joined by a smooth curve, a line of constant dryness ac' , Fig. 19, is obtained. A number of these constant quality lines are shown drawn on the temperature entropy diagram in Fig. 21.

45. Constant Volume Lines.—Consider the isothermal line ab , Fig. 19. If only $\frac{1}{n}$ of a pound of water has been evaporated into drysteam, the change of entropy

will be $\frac{L}{nT}$, and this will be represented by the point c such that

$$\frac{ac}{ab} = \frac{1}{n}$$

The volume of the steam will be $\frac{1}{n}$ of the volume at point b , and the volume of the mixture $\left(1 - \frac{1}{n}\right)$ pound of water and $\frac{1}{n}$ pound of steam, will be for all practical purposes equal to $\frac{1}{n}$ of the volume at b since the volume of $\left(1 - \frac{1}{n}\right)$ pound of water is very small compared with the volume

of 1 pound of steam, particularly at low pressures. In the case of high-pressure steam, where the specific volume is low, the proportional error made in neglecting the volume of water will be greater than when the specific volume is higher, hence for absolute accuracy the point c must be so chosen as to include the volume of the water. In order to draw any constant volume line we may therefore proceed as follows:—

On the saturated steam line find (by means of steam tables) the points where the volume of the steam is 1, 2, 3, 4, 5, etc., cubic feet. Draw isothermals through these points. Fig. 20 shows a constant volume line drawn for 1 cubic foot; the length ac is made $\frac{1}{2}$ of a_2 , $a'd'$ $\frac{1}{3}$ of a'_3 , $a''c''$ $\frac{1}{4}$ of a''_4 and so on, the curve being obtained by drawing a smooth curve through the points $c, c', c'',$ etc. A number of these constant volume lines are shown drawn on the temperature-entropy diagram in Fig. 21.

46. Calculation of the Dryness of Steam after Isentropic Expansion. The Adiabatic Equation.—Suppose the steam to be initially dry and saturated at temperature T , its condition being represented by the point c in the temperature-entropy diagram Fig. 22. During expansion to T_2 there is no gain or loss of heat, the difference between the initial and final internal energies being equal to the work done during the expansion (Art. 10). The expansion curve on the entropy diagram will be represented by the straight vertical line cf , the point f representing the condition of the steam at the temperature T_2 after expansion.

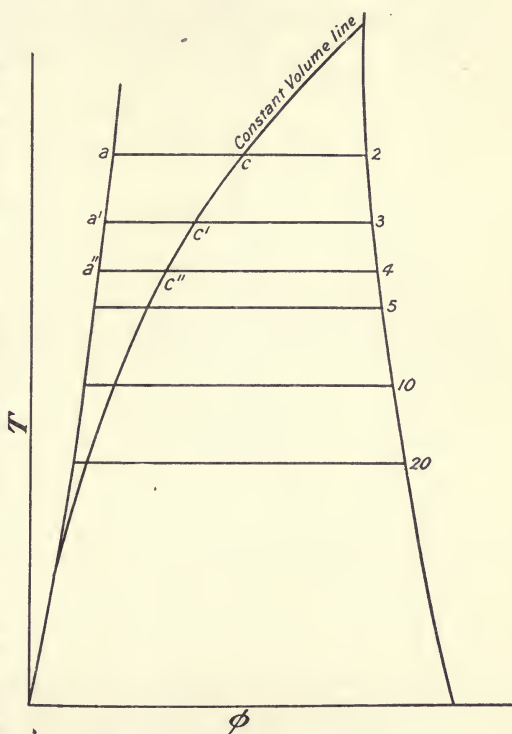

FIG. 20.—Constant volume line.

The dryness fraction after expansion will therefore be

$$x_2 = \frac{af}{ae}$$

Again, if the steam was originally wet its condition would be repre-

TEMPERATURE-ENTROPY DIAGRAM FOR WATER-STEAM.

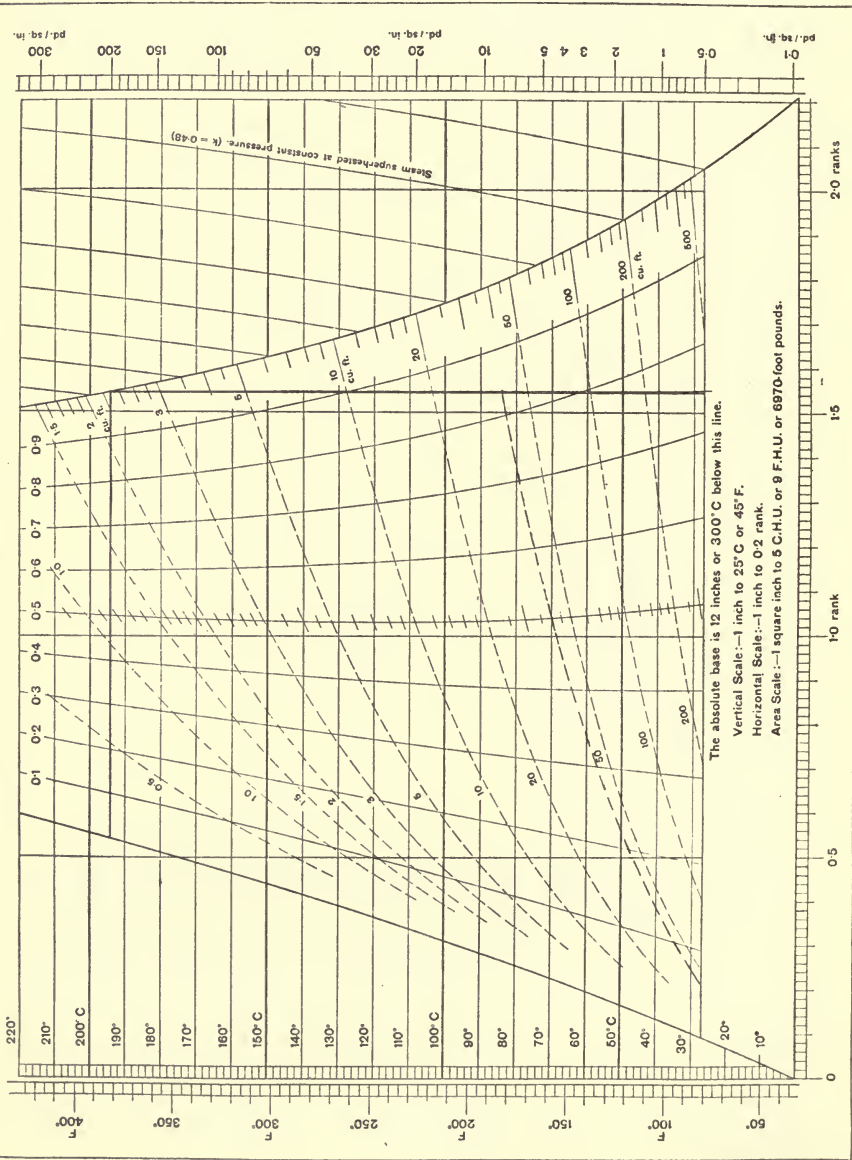

FIG. 21.—Complete temperature-entropy diagram.

sented by the point h , such that the initial dryness fraction = $\frac{bh}{bc}$, and at the end of expansion, the dryness fraction would be

$$x_2 = \frac{ag}{ae}$$

Let the dryness fraction before expansion be denoted by x_1 , then—

$$\text{Entropy of the steam at } T_1 = \log_{\epsilon} \frac{T_1}{492} + \frac{x_1 L_1}{T_1} \quad \dots (1)$$

$$\text{and entropy of the steam at } T_2 = \log_{\epsilon} \frac{T_2}{492} + \frac{x_2 L_2}{T_2} \quad \dots (2)$$

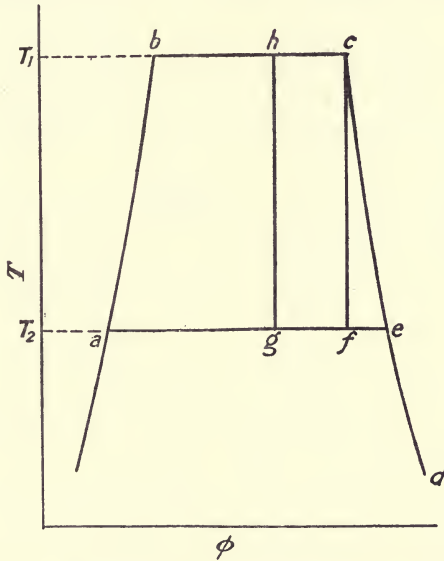

FIG. 22.—Isentropic or adiabatic expansion of steam.

Now the entropy remains constant throughout the expansion

$$\therefore \log_{\epsilon} \frac{T_1}{492} + \frac{x_1 L_1}{T_1} = \log_{\epsilon} \frac{T_2}{492} + \frac{x_2 L_2}{T_2}$$

$$\frac{x_2 L_2}{T_2} = \log_{\epsilon} \frac{T_1}{T_2} + \frac{x_1 L_1}{T_1}$$

or
$$x_2 = \frac{T_2}{L_2} \left(\frac{x_1 L_1}{T_1} + \log_{\epsilon} \frac{T_1}{T_2} \right) \quad \dots (3)$$

EXAMPLE.—By means of an entropy chart determine—

(a) The dryness fraction at the end of expansion when one pound of dry saturated steam at 366° F. expands adiabatically to 225° F.

(b) The dryness fraction at the end of expansion when one pound of wet steam with dryness fraction 0.75 and temperature 380° F. expands adiabatically to 240° F.

$$\begin{aligned}
 (a) \quad 366^\circ \text{F.} &= 366 + 461 = 827^\circ \text{ abs.} = T_1 \\
 225^\circ \text{F.} &= 225 + 461 = 686^\circ \text{ abs.} = T_2 \\
 L_{366} &= 1114 - 0.7 \times 366 = 1114 - 256.2 = 857.8 \\
 L_{225} &= 1114 - 0.7 \times 225 = 1114 - 157.5 = 956.5
 \end{aligned}$$

Let x = dryness fraction after expansion

$$\text{then } x = \frac{AE}{AD} \text{ (see Fig. 23).}$$

$$\begin{aligned}
 &= \frac{AF + FE}{AD} = \frac{\log_e \frac{827}{686} + \frac{857.8}{827}}{\frac{956.5}{686}} = \frac{0.1870 + 1.0372}{1.3943} \\
 &= 0.878
 \end{aligned}$$

$$\begin{aligned}
 (b) \quad T_1 &= 380 + 461 = 841 \text{ and } T_2 = 240 + 461 = 701 \\
 L_{380} &= 1114 - 0.7 \times 380 = 1114 - 266 = 848 \\
 L_{240} &= 1114 - 0.7 \times 240 = 1114 - 168 = 946
 \end{aligned}$$

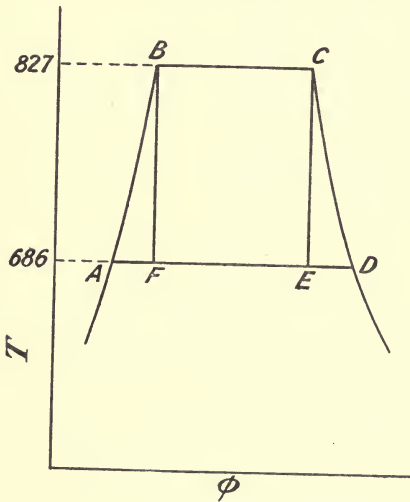

FIG. 23.

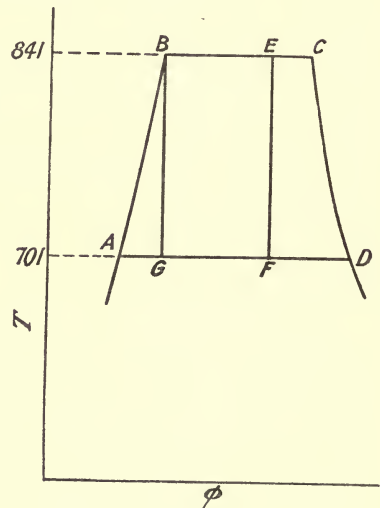

FIG. 24.

In Fig. 24 $\frac{BE}{BC}$ = initial dryness fraction = 0.75

$$\begin{aligned}
 \text{and final dryness fraction} &= \frac{AF}{AD} = \frac{AG + GF}{AD} = \frac{AG + 0.75 \times BC}{AD} \\
 &= \frac{\log_e \frac{841}{701} + 0.75 \times \frac{848}{841}}{\frac{946}{701}} \\
 &= \frac{0.1821 + 0.7562}{1.3495} = 0.695.
 \end{aligned}$$

The student should check the above results by means of the temperature-entropy diagram.

47. Gain of Entropy due to Throttling or Wire-drawing.—

There are two cases to be considered. In the first case, the steam after throttling may be either wet or it may be just dry saturated; in the second case the steam may be initially dry—it will then be superheated after throttling (Art. 38).

First Case, in which the Steam is not Superheated after Throttling.—Let the steam have an initial dryness fraction x_1 , and let

throttling take place between absolute temperatures T_1 and T_2 . The temperature-entropy diagram is shown in Fig. 25. The condition of the steam before throttling is represented by the point c such that

$$x_1 = \frac{bc}{bl}$$

The expansion is not isentropic because no work is done, so that the condition of the steam after throttling will be represented by the point d , such that

$$x_2 = \frac{fd}{fn}$$

where x_2 denotes the dryness fraction after throttling down to temperature T_2 . The length ed will therefore represent the gain in entropy, which may be calculated as follows:—

$$\left. \begin{array}{l} \text{Entropy at } T_1 \\ \text{reckoned from } T_2 \end{array} \right\} = fe = fn + bc$$

$$fe = \log_e \frac{T_1}{T_2} + \frac{x_1 L_1}{T_1}$$

$$\left. \begin{array}{l} \text{Entropy at } T_2 \\ \text{reckoned from } T_2 \end{array} \right\} = fd = \frac{x_2 L_2}{T_2}$$

$$\therefore \text{gain of entropy} = ed = fd - fe$$

$$= \frac{x_2 L_2}{T_2} - \frac{x_1 L_1}{T_1} - \log_e \frac{T_1}{T_2} \dots (1)$$

But since the heat contents remain the same, the total heat after throttling will be the same as the total heat before throttling, *i.e.*

$$T_2 - 492 + x_2 L_2 = T_1 - 492 + x_1 L_1$$

$$\therefore x_2 = \frac{T_1 - T_2 + x_1 L_1}{L_2}$$

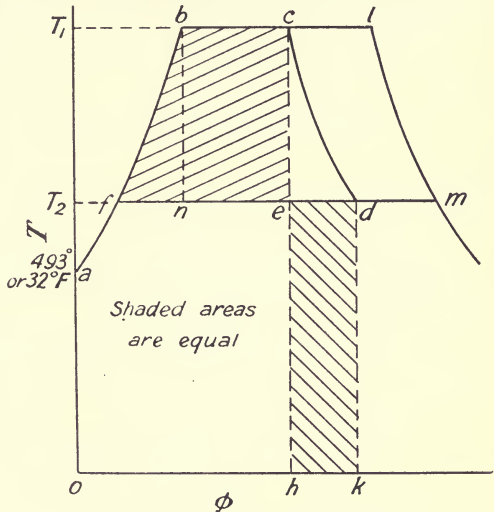

FIG. 25.—Throttling of steam.

Substituting this value for x_2 in (1) we get—

$$\begin{aligned} ed &= \frac{L_2}{T_2} \left(\frac{T_1 - T_2 + x_1 L_1}{L_2} \right) - \frac{x_1 L_1}{T_1} - \log_e \frac{T_1}{T_2} \\ &= \frac{T_1 - T_2 + x_1 L_1}{T_2} - \frac{x_1 L_1}{T_1} - \log_e \frac{T_1}{T_2} \\ &= \left(\frac{T_1 - T_2}{T_2} \right) \left(1 + \frac{x_1 L_1}{T_1} \right) - \log_e \frac{T_1}{T_2} \dots \dots \dots (2) \end{aligned}$$

Alternative Method.—The above result may be obtained by a more direct method as follows—

Reckoning all heat quantities from the absolute zero of temperature we have

Total heat per pound before throttling = area *oabch*
 Total heat per pound after throttling = area *oafdk*
 \therefore area *oabch* = area *oafdk*

and since the area *oafeh* is common, it follows that

$$\text{area } fbce = \text{area } edkh$$

Now the area *fbce* represents the work done per pound of steam on the Rankine cycle (see Art. 57), namely

$$(T_1 - T_2) \left(1 + \frac{x_1 L_1}{T_1} \right) - T_2 \log_e \frac{T_1}{T_2} \text{ B.Th.U. (Art. 57)}$$

$$\therefore \text{area } edkh = ed \times T_2 = (T_1 - T_2) \left(1 + \frac{x_1 L_1}{T_1} \right) - T_2 \log_e \frac{T_1}{T_2}$$

$$\text{or } ed = \frac{T_1 - T_2}{T_2} \left(1 + \frac{x_1 L_1}{T_1} \right) - \log_e \frac{T_1}{T_2} \text{ as above.}$$

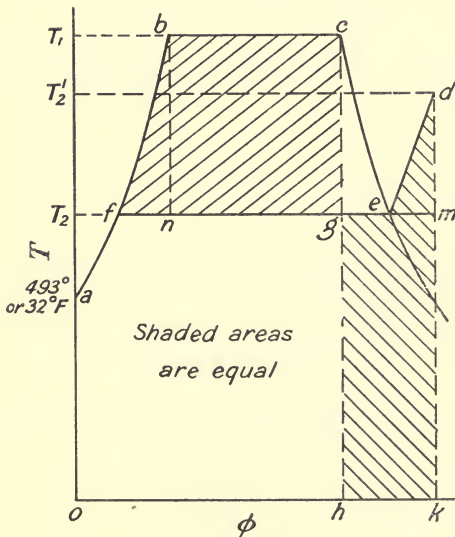

Case when the Steam is Dry Saturated before Throttling.—The condition of the steam at pressure p_1 and temperature T_1 before throttling is represented by the point *c* on the saturated steam line Fig. 26. After throttling down to a pressure p_2 the condition of the steam is represented by the point *d* on this constant pressure line in the superheated region of the temperature-entropy diagram, the isothermal *fe* being drawn for saturated steam at the temperature T_2 corresponding to the final pressure p_2 .

The length *gm* represents the gain in entropy and may be found as follows :—

FIG. 26.—Steam superheated after throttling.

Entropy at pressure p_1 }
reckoned from T_2 } = $fg = fn + bc$

$$fg = \log_e \frac{T_1}{T_2} + \frac{L_1}{T_1}$$

Entropy at pressure p_2 }
reckoned from T_2 } = $fm = fe + em$

$$= \frac{L_2}{T_2} + 0.48 \log_e \frac{T'_2}{T_2}$$

where T'_2 is the final temperature of the superheated steam after throttling.

\therefore gain of entropy = $gm = fm - fg$

$$= \frac{L_2}{T_2} + 0.48 \log_e \frac{T'_2}{T_2} - \log_e \frac{T_1}{T_2} - \frac{L_1}{T_1} \quad (2)$$

Now the total heat after throttling is equal to the total heat before throttling, *i.e.*

$$H_2 + 0.48 (T'_2 - T_2) = T_1 - 492 + L_1 \quad (3)$$

where H_2 denotes the total heat per pound of dry saturated steam at pressure p_2 , being obtained from steam tables, or in their absence from

$$H_2 = T_2 - 492 + L_2$$

From equation (3) the final temperature of the steam can be calculated and the substitution of its value in (2) gives the gain of entropy.

It should be noticed that reckoning the total heat from the absolute zero of temperature,

Total heat per pound before throttling = area *oabch*

Total heat per pound after throttling = area *oafedk*

and since the area *oafgh* is common it follows that

$$\text{area } fbcg = \text{area } gedkh.$$

EXAMPLE.—Find the gain of entropy when dry steam at a pressure of 210 pounds per square inch absolute is wire-drawn to a pressure of 30 pounds per square inch absolute.

First find the temperature after throttling, using equation (3)

$$H_2 + 0.48 (T'_2 - T_2) = T_1 - 492 + L_1$$

Substituting the values of H_2 , T_2 , T_1 and L_1 from steam tables we get—

$$1163.9 + 0.48 T'_2 - 0.48 \times 710.3 = 846 - 492 + 839.6$$

from which

$$T'_2 = 770^\circ \text{ F. absolute.}$$

From (2) we find the gain of entropy to be

$$\begin{aligned} & \frac{L_2}{T_2} + 0.48 \log_e \frac{T'_2}{T_2} - \log_e \frac{T_1}{T_2} - \frac{L_1}{T_1} \\ & \frac{945.1}{710.3} + 0.48 \log_e \frac{770}{710.3} - \log_e \frac{846}{710.3} - \frac{839.6}{846} \\ & = 1.3305 + 0.0388 - 0.1749 - 0.9924 \\ & = 0.202 \end{aligned}$$

48. Heat-Entropy Diagram for Steam. Mollier Diagram.—In this diagram the rectangular co-ordinates are entropy and total heat. A

diagram of this description, using British units, is supplied with Marks and Davis' "Steam Tables."¹ As indicated in Fig. 27 this diagram is only drawn for steam in the neighbourhood of the saturation curve, the range of pressure used being large enough to include all cases likely to be met with in practice. Vertical lines on the diagram are lines of constant

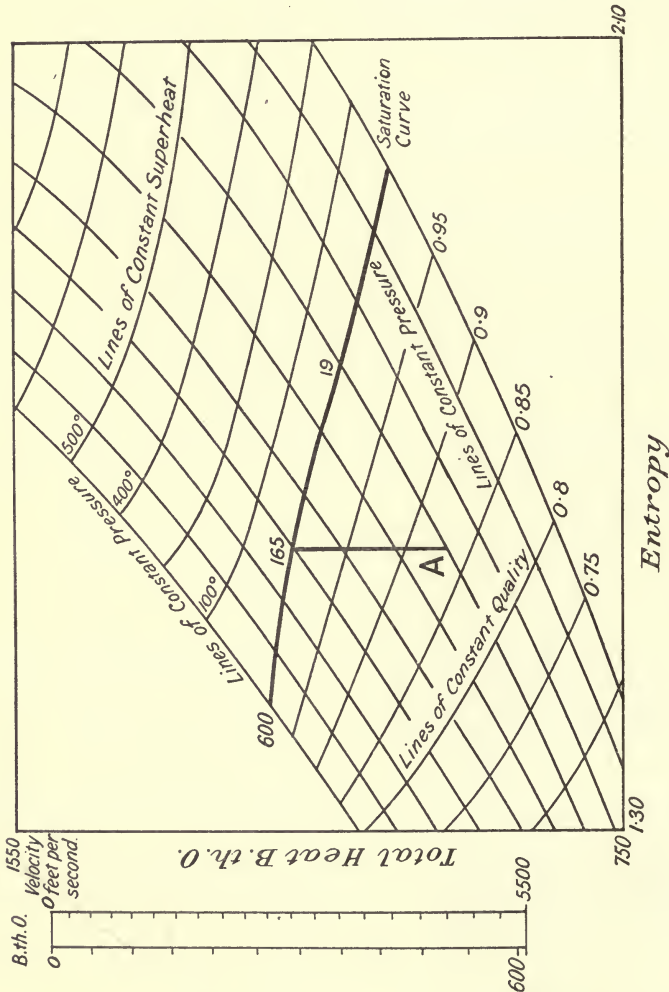

FIG. 27.—Mollier diagram.

entropy and horizontal lines are lines of constant heat. The nearly straight lines running diagonally upwards from left to right are lines of constant pressure; below the saturation curve, the nearly straight lines running downwards from left to right are lines of constant quality, whilst

¹ A heat-entropy diagram is also published by Oliver and Boyd, Edinburgh, price 3s. in which entropy is plotted vertically.

above the saturation curve similar lines are lines of constant superheat. A scale is given on the left of the diagram, parallel to the scale of heat units, from which the velocity attained by adiabatic expansion between any two pressures may be read off directly; this is of special use when solving problems on the flow of steam through nozzles, etc., and will be referred to later (see Art. 106).

The diagram may be used to solve all problems regarding the condition of steam before and after isentropic expansion or compression, and throttling. For instance, take the example worked out in Art. 46. Here the dry saturated steam expands isentropically from 366° F. to 225° F. From steam tables we find that the absolute pressures corresponding to these temperatures are 165 and 18.9 pounds per square inch. From the point on the saturation curve for 165 pounds pressure follow down the vertical constant entropy line until it crosses the line of constant pressure at 18.9 pounds absolute. The point of intersection A (Fig. 27) gives the quality of the steam, which is read off directly to be 0.877, which agrees very well with the calculated result obtained in Art. 46.

Consider next the problem on the throttling calorimeter worked out in Example 2, Art. 40. Here the pressure before throttling was 165 pounds absolute and after throttling 16.7 pounds absolute. The temperature after throttling was 290° F., *i.e.* the steam was superheated ($290 - 218.5$) = 71.5° F. Find the point on the constant pressure line for 16.7 pounds for which the superheat is 71.5° F., then follow the horizontal line of constant total heat which passes through this point, until it intersects the constant pressure line for 16.7 pounds absolute; the point of intersection gives the initial dryness fraction of the steam, which is read off to be 0.99, a value which agrees with the calculated one.

We will next check the result obtained in the example worked out in Art. 47. Here dry saturated steam at 210 pounds absolute is wire-drawn to 30 pounds absolute, it is required to find the gain in entropy.

From the point on the saturation curve where the pressure is 210 pounds absolute, follow the line of constant heat which passes through this point until it intersects the constant pressure line for 30 pounds absolute. The point of intersection gives the entropy as 1.746, while at 210 pounds the entropy is seen to be 1.541. The gain in entropy is therefore

$$1.746 - 1.541 = 0.205.$$

The calculated result obtained was 0.202. The difference between these two results is doubtless due to the specific heat of steam not being constant and equal to 0.48 as was assumed in Art. 47.

49. Total Heat-Pressure Diagram.—A diagram of this type is also supplied with Marks and Davis' "Steam Tables." The rectangular co-ordinates are pressure and total heat, the total heats being shown as ordinates. Vertical lines (Fig. 28) are lines of constant pressure; measurements along any of these vertical lines give the heat supply accompanying changes of volume or quality at constant pressure. Horizontal lines are lines of constant total heat; they show the change of volume and the condition of the steam resulting from throttling. The scale of abscissæ is a uniform scale of temperatures of saturated steam, which gives a

varying scale of steam pressures. This varying scale has the advantage of spreading out the specific volume curves at low pressures. For a

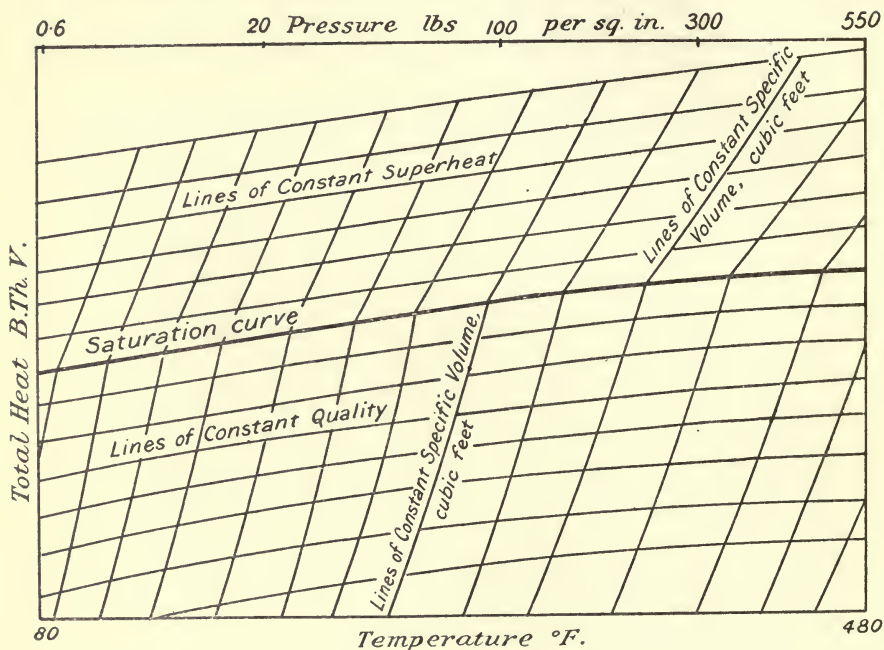

FIG. 28.—Total heat-pressure diagram.

complete description of the use of this diagram the reader is referred to Marks and Davis.

EXAMPLES III

1. Given the following data, estimate the volume of 1 pound of dry saturated steam at 100 pounds per square inch absolute—

p lbs. per sq. in. abs.	90	95	103	110
Temperature, ° F.	320.3	324.1	330.0	334.8

Take the latent heat at 100 pounds per square inch as 888 B.Th.U.

2. Calculate the total heat of evaporation and the internal energy of 1 pound of saturated steam at a pressure of 160 pounds per square inch absolute ($t = 363.6^{\circ}$ F.), (a) when the steam is dry, and (b) when the dryness fraction of the steam is 0.70. Given specific volume of dry saturated steam at this pressure = 2.83 cubic feet.

3. The following data were obtained from trials run on three different boilers A, B, and C, the same coal of calorific value 14,000 B.Th.U. per pound being used in each

trial. Calculate for each boiler, (a) the equivalent evaporation per pound of coal from and at 212° F., (b) the efficiency of the boiler.

	A	B	C
Steam pressure (pounds per square inch absolute)	140	180	160
Temperature of saturation, $^{\circ}$ F.	353.1	373.1	363.6
Feed temperature, $^{\circ}$ F.	50	65	100
Dryness of steam, per cent.	98	98.5	—
Temperature of superheated steam, $^{\circ}$ F.	—	—	500
Water evaporated per pound of coal under working conditions	9.2	8.8	8.5

For boiler C take the specific heat of steam to be 0.5.

4. Measurements from an indicator diagram taken on a steam engine show that at a certain instant the volume of the steam is 1.95 cubic feet and the pressure 70 pounds per square inch absolute. If the actual weight of steam in the cylinder is 0.5 pound, estimate the dryness of the steam at that instant.

5. In an engine cylinder the clearance volume is 2 cubic feet. The boiler pressure is 100 pounds per square inch absolute and the pressure in the cylinder at the instant steam is admitted is 15 pounds per square inch absolute. The dryness fraction of the boiler steam is 0.9 and that of the steam shut in the clearance 0.95. Find the amount of steam admitted, and the dryness fraction, when the pressure in the clearance reaches 100 pounds absolute. Neglect all losses and assume the cylinder to be a non-conductor of heat. Given—

Pressure.	h .	L.	Specific Volume.
100	298.3	888	4.429
15	181.0	969.7	26.27

6. Boiler steam of dryness fraction 0.97 and at a pressure of 340 pounds per square inch absolute ($t = 429^{\circ}$ F.) is wire-drawn to 200 pounds per square inch ($t = 382^{\circ}$ F.) absolute. Calculate the dryness fraction on the engine side of the reducing valve.

7. In a test on a condensing plant the following results were obtained: (a) steam condensed per hour 2100 pounds; (b) temperature of exhaust steam entering the condenser 126° F.; (c) weight of circulating water used per minute 510 pounds; (d) temperature of circulating water as it enters and leaves the condenser 55° F. and 90° F. respectively; (e) temperature of the air pump discharge 95° F. Calculate the dryness fraction of the exhaust steam as it enters the condenser.

8. In a test with a throttling calorimeter the following data were obtained:—Pressure in main steam pipe 153 pounds per square inch absolute ($t = 360$ F. and $L = 862$); temperature after wire-drawing 240° F.; pressure after wire-drawing 17.19 pounds per square inch absolute ($t = 220^{\circ}$ F., $H = 1153$). Estimate the dryness of the steam in the main steam pipe. Assume the specific heat, $C_p = 0.5$.

9. The following data were obtained in a test with a combined throttling and separating calorimeter:—Water from separator 1.5 pounds, steam condensed after wire-drawing 32 pounds. Steam temperature before wire-drawing 340° F., after wire-drawing 225° F.; pressure after wire-drawing 15 pounds per square inch absolute ($t = 213$, $H = 1150.7$). Estimate the dryness of the steam. Assume specific heat, $C_p = 0.5$.

10. Using steam tables, calculate the dryness fraction of steam from the following observations taken from a throttling calorimeter:—Pressure in main steam pipe 80.3 pounds per square inch gauge; temperature of steam in calorimeter 260° F.; manometer reading 3 inches of mercury; barometer reading 29 inches.

11. Calculate the gain in entropy when one pound of water at 60° F. is converted into steam at 296° F. and then superheated to 500° F. (Assume $C_p = 0.5$.)

12. By means of an entropy chart determine:—

- (a) The dryness fraction after expansion when dry saturated steam at 180 pounds per square inch absolute expands isentropically to 15 pounds per square inch absolute.
 (b) The dryness after expansion when steam at 280° F. and of dryness 0.8 expands isentropically to 110° F.
 (c) Steam at 100 pounds per square inch absolute is superheated 200° F. and then expands isentropically down to 4 pounds per square inch absolute. Find its dryness after expansion.
 (d) What must be the final pressure in (c) in order that the steam may be just dry and saturated after expansion?

13. Steam at a pressure of 150 pounds per square inch absolute is superheated 60° F. and then expands isentropically. At what pressure will the steam become dry and saturated?

14. Steam at 200 pounds per square inch absolute ($t = 382^\circ \text{F.}$) is superheated 100° F. It is then passed through a reducing valve and has its pressure reduced to 15 pounds per square inch absolute ($t = 213^\circ \text{F.}$). Determine the temperature and condition of the steam after wire-drawing and calculate, without using steam tables, the change of entropy. Take the average specific heat as 0.5.

15. Steam passing to an engine has a pressure of 150 pounds per square inch absolute ($t = 358^\circ \text{F.}$) and a temperature of 600° F. when in the main steam pipe. Before entering the engine it is throttled down to 100 pounds per square inch absolute ($t = 328^\circ \text{F.}$), and is then expanded adiabatically down to 25 pounds per square inch absolute ($t = 240^\circ \text{F.}$). Determine, without using steam tables, the temperature and condition of the steam before and after expansion.

16. Steam at a temperature of 330° F. and of dryness 0.9 is wire-drawn to 190° F. Calculate the gain of entropy.

17. Steam at a pressure of 220 pounds per square inch absolute ($t = 390^\circ \text{F.}$) and of dryness 0.97 is wire-drawn to a pressure of 13 pounds per square inch absolute. Determine the condition of the steam after throttling and the gain of entropy. Given

p .	$t^\circ \text{F.}$	L.
220	390	836.2
13	205.9	974.2

18. Solve Problem 17 if the steam is initially dry and saturated at 220 pounds absolute.

19. Solve Problems 12 to 18 inclusive by means of a total heat-entropy (Mollier) diagram.

20. At two points on the expansion curve of a steam engine indicator diagram the following values of volume and pressure (a) and (b) were obtained:—

v , cubic feet.	p , pounds per square inch abs.	Temperature, °C.	Vol. of 1 lb. of dry sat. steam.	ϕ_{10}	ϕ_2
—	60.4	145	7.01	0.430	1.634
(a) 2.8	52.0	139.4	8.10	0.4174	1.6454
(b) 6.1	23.0	117.1	17.40	0.3595	1.6695

The initial temperature being 145° C. and the pressure 60.4 pounds per square inch absolute, find how much water was in the cylinder just before admission (the temperature then being 63° C.) and how much steam was condensed on admission. Neglect the amount of steam present before admission, assume the cylinder to be perfectly non-conducting and the water and steam all at a uniform temperature, and the admission steam dry saturated.

CHAPTER IV

THEORY OF THE STEAM ENGINE

50. Work done during the Adiabatic Expansion of Steam.—

It has been shown in Art. 10 that when a perfect gas expands adiabatically, the law of the expansion curve is $p v^\gamma = \text{constant}$ where $\gamma = \frac{C_p}{C_v}$. Saturated steam, however, is a vapour, not a perfect gas, and although the law of expansion may be represented by the empirical formula $p v^n = \text{constant}$, it would be meaningless to say that the index “ n ” for steam is the ratio of the two specific heats, because as the expansion goes on the steam becomes wetter (Art. 46), and it is impossible to say what the ratio of the specific heats may be; in any case it would be a variable quantity. The question arises then, what value of “ n ” is to be taken? Dr. Zeuner gives the value

$$n = 1.035 + 0.1x \quad \dots \dots \dots (1)$$

where x = the initial dryness fraction of the steam.

If the steam be initially dry the law of the expansion curve becomes

$$p v^{1.135} = \text{constant} \quad \dots \dots \dots (2)$$

Rankine gave an approximate value of “ n ” as $\frac{10}{9}$, which is too small if the steam is initially dry, and corresponds to the case when the steam has an initial dryness fraction of about 0.75.

Let the steam expand from the state $p_1 v_1$ to the state $p_2 v_2$; the work done will be

$$W = \frac{p_1 v_1 - p_2 v_2}{n - 1} \text{ (by Art. 9)} \quad \dots \dots (1)$$

In using this equation, the final volume v_2 will have to be calculated by first finding the dryness fraction after expansion (see Art. 46) and then multiplying the dryness fraction by the volume the steam would have if it was dry and saturated at the pressure p_2 .

Another expression for the work done follows directly from the definition of an adiabatic expansion given in Art. 10, namely,

$$\text{Work done} = \text{change of internal energy.}$$

Using the notation of Art. 35 this becomes

$$\begin{aligned} W &= I_1 - I_2 \text{ heat units} \quad \dots \dots \dots (2) \\ &= (H_1 - E_1) - (H_2 - E_2) \text{ heat units} \end{aligned}$$

or
$$W = H_1 - H_2 - \frac{144}{J} (p_1 v_1 - p_2 v_2) \quad \dots \dots (3)$$

in which the pressures are measured in pounds per square inch, and the volumes in cubic feet.

EXAMPLE 1.—Calculate the work done when 1 pound of steam expands adiabatically from 150 pounds per square inch absolute to 16 pounds per square inch absolute, (a) when the steam is initially dry and saturated, (b) when the initial dryness fraction is 0.8.

From steam tables, p. 480, we find the following—

p .	t .	h .	L.	v .
150	358.5	330.2	863.2	3.012
16	216.3	184.4	967.6	24.79

From (3) $W = H_1 - H_2 - \frac{144}{778}(p_1v_1 - p_2v_2)$.
 (a) Here $H_1 = 330.2 + 863.2 = 1193.4$ B.Th.U.

From a temperature-entropy diagram, dryness fraction after expansion (Art. 46)

$$= 0.874$$

$$H_2 = 184.4 + 967.6 \times 0.874 = 184.4 + 845.7 = 1030.1 \text{ B.Th.U.}$$

$$v_1 = 3.012 \text{ cubic feet and } v_2 = 24.79 \times 0.874 = 21.67 \text{ cubic feet}$$

$$\therefore W = 1193.4 - 1030.1 - \frac{144}{778}(150 \times 3.012 - 16 \times 21.67)$$

$$W = 163.3 - 19.5 = 143.8 \text{ B.Th.U.}$$

(b) By the method of Art. 46 we find $x_2 = 0.725$.

Here $H_1 = 330.2 + 0.8 \times 863.2 = 330.2 + 690.6 = 1020.8$
 $H_2 = 184.4 + 967.6 \times 0.725 = 184.4 + 701.5 = 885.9$
 $v_1 = 0.8 \times 3.012 = 2.41$ cubic feet
 $v_2 = 0.725 \times 24.79 = 17.97$ cubic feet
 $\therefore W = 1020.8 - 885.9 - \frac{144}{778}(150 \times 2.41 - 16 \times 17.97)$
 $= 134.9 - 13.7 = 121.2 \text{ B.Th.U.}$

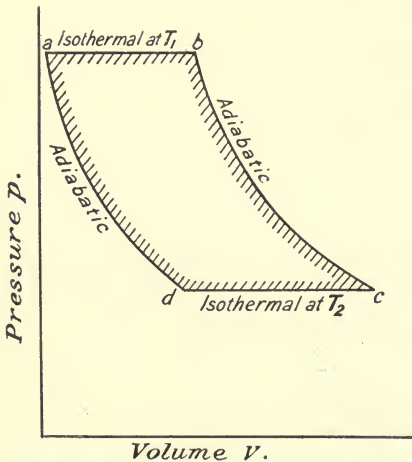

FIG. 29.— p - v diagram for steam engine working in Carnot cycle.

51. Perfect Steam Engine working on the Carnot Cycle.

—Fig. 29 shows the pressure-volume diagram for the cycle.

Stage "ab."—Heat is supplied to water at a and converts it into steam at constant pressure; the steam expands isothermally at constant pressure and at constant temperature T_1 .

Stage "bc."—When the water is all evaporated to dry saturated steam, the source of heat is removed and the steam allowed to continue the expansion adiabatically down to temperature T_2 .

Stage "cd."—The steam is now compressed isothermally at temperature T_2 , being condensed by rejecting heat to the condenser.

Stage "da."—The cycle is completed by stopping the condensation of the steam at some point d and

then compressing adiabatically. If the point *d* has been chosen correctly the cycle will be completed by restoring the working fluid to its initial condition as water at temperature T_1 .

Since the cycle is closed and therefore reversible, all the heat being taken in at the higher temperature T_1 , and all rejected at the lower temperature T_2 , the efficiency will be

$$\frac{T_1 - T_2}{T_1} \text{ (as in Art. 21)}$$

Let L_1 be the latent heat of the steam at temperature T_1 , then the amount of heat supplied during the cycle will be L_1 and the work done is

$$L_1 \times \frac{T_1 - T_2}{T_1} \dots \dots \dots (1)$$

Instead of assuming the working fluid to consist wholly of water at *a* and steam at *b*, *ab* (Fig. 29) might be taken to represent the *partial* evaporation of an original mixture of water and steam. In this case if x_b denotes the dryness fraction of the mixture at *b* and x_a the dryness fraction at *a*, the amount of heat supplied during the cycle will be

$$(x_b - x_a)L_1$$

and work done would be

$$\begin{aligned} &(x_b - x_a)L_1 \times \frac{T_1 - T_2}{T_1} \\ &= \frac{L_1(x_b - x_a)(T_1 - T_2)}{T_1} \dots \dots \dots (2) \end{aligned}$$

If the above cycle could be realised in practice we should have a thermodynamically perfect steam engine using saturated steam and like any other perfect heat engine, its efficiency would depend *solely* upon the working range of temperature $T_1 - T_2$. The ideal efficiencies of an engine working on this cycle have been worked out for several cases, assuming condensation to take place at the lower temperature limit of 520° absolute, *i.e.* 60° F. and tabulated below.

Absolute pressure, lbs. per square inch.	Temperature, T_1	Efficiency $\frac{T_1 - T_2}{T_1}$
40	728.17	0.284
60	753.57	0.308
80	772.87	0.326
100	788.63	0.339
120	802.06	0.350
140	813.83	0.359
160	824.34	0.368
180	833.89	0.375
200	842.64	0.381
220	850.70	0.387
240	858.40	0.393
260	865.60	0.398
280	872.10	0.402
300	878.50	0.407

52. Limits of Temperature Permissible.—The lower limit T_2 is the temperature of the available water supply, and cannot of course be

less than 492° (32° F.). To the higher temperature T_1 a limit is set in practice by the pressure, which becomes very high for comparatively low temperatures and causes mechanical difficulties with regard to the strength of the working parts of the engine and to the lubrication of the same. As seen above, even with the high pressure of 300 lbs. per square inch (which is about the limit in practice), the temperature is only 878° absolute or say 420° F., and taking 60° F. as the lowest temperature, the ideal efficiency would be about 40 per cent. It is impossible to attain this result in practice because no steam engine works on this cycle, and many of the causes of imperfection cannot be removed. From a thermodynamic point of view the worst thing to be considered is the irreversible drop in temperature between the furnace and the boiler. The combustion of the fuel gives a very high temperature, but a great portion of the heat which could be converted into work is immediately lost, as it were, by the fall in temperature which takes place before the conversion of heat into work occurs.

53. How closely the Process is carried out in Practice.—The first stage “*ab*” (Fig. 29) may be carried out as in theory.

Second Stage, “*bc*.”—There is no reason why the expansion should not be approximately adiabatic, given an isolated cylinder and high piston speed.

Third Stage, “*cd*” may be performed as in theory by exhausting into the condenser, in which case the final pressure and temperature in the cylinder after expansion must be the same as the pressure and temperature in the condenser.

Fourth Stage, “*da*.”—The cycle cannot be completed by the adiabatic compression owing to the existence of the separate condenser. The best that can be done is to return the condensed water through an economiser or feed-water heater to the boiler by means of a feed pump or injector.

Actually the exhaust is stopped before the end of the exhaust stroke, and the steam compressed or *cushioned* for mechanical reasons, and to reduce the loss of power due to clearance. This does not materially effect the thermodynamic efficiency. Again, the expansion is never carried right down to the condenser or back pressure, as below a certain pressure, the work done in the engine cylinder is less than that lost by engine friction and condensation.

The indicator diagram of an engine working on this cycle (assuming no clearance) is shown in Fig. 30. “*ab*” represents the admission of the high-pressure boiler steam, “*b*” is the point of cut off, “*bc*” is the expansion line (adiabatic), and “*cd*” the exhaust.

Let p_1 = initial pressure in pounds per square foot at “*a*” or “*b*”
 p_2 = final or exhaust pressure at “*c*” or “*d*”
 v_1 = initial volume (at “*b*”) before expansion
 r = ratio of expansion.

Then the work done per pound during admission = $p_1 v_1 \dots$ (1)

Then the work done per pound during expansion }
 to volume rv_1 } = $\frac{p_1 v_1 - p_2 r v_1}{n - 1}$ (2)

Work done on the steam during exhaust = $p_2 r v_1 \dots$ (3)

„ by the feed pump = $(p_1 - p_2) V_w$ (4)

Heat supplied = $(H_1 - h_2)$. (5)

Hence the nett work done per pound of steam

$$= p_1 v_1 + \frac{p_1 v_1 - p_2 r v_1}{n - 1} - p_2 r v_1 - (p_1 - p_2) V_w \dots (6)$$

and the efficiency is—

$$\frac{\text{nett amount of work done}}{\text{heat supplied}}$$

$$= \frac{p_1 v_1 + \frac{p_1 v_1 - p_2 r v_1}{n - 1} - p_2 r v_1 - (p_1 - p_2) V_w}{J(H_1 - h_2)} \dots (7)$$

This is also considered by a different method in Art. 55.

The above reasoning is for complete expansion, *i.e.* the steam expands until its temperature is the same as the temperature of the condenser. If

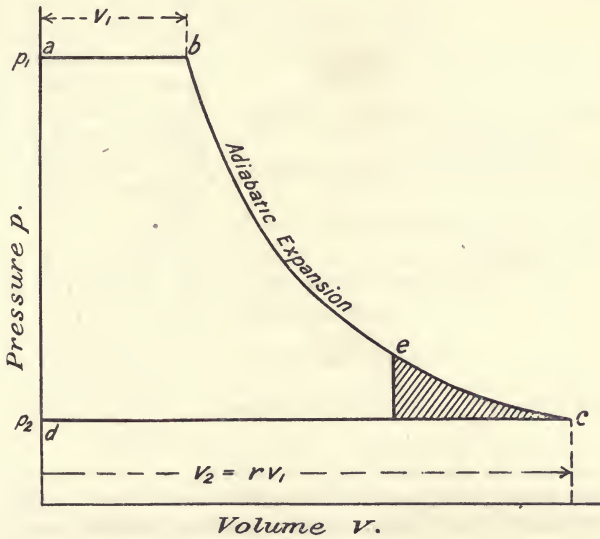

FIG. 30.

the expansion is incomplete, as it is invariably in practice, equation (2) still holds if p_2 is taken as the pressure after expansion, and in equation (4) the pressure in the condenser must be substituted instead of p_2 , in that case calling p_b the back pressure the efficiency becomes

$$= \frac{p_1 v_1 + \frac{p_1 v_1 - p_2 r v_1}{n - 1} - p_2 r v_1 - (p_1 - p_b) V_w}{J(H_1 - h_2)} \dots (8)$$

Incomplete expansion is illustrated in Fig. 30, the expansion being stopped at some point "e." It results in a loss of work done on the piston represented by the toe of the diagram shown shaded.

The theoretical efficiency as calculated above always falls short of the Carnot efficiency because of the absence of the fourth stage, *viz.* the adiabatic compression to the original temperature T_1 . Without the

compression some of the heat is taken in at temperatures varying from T_2 to T , therefore as shown in Art. 24 the efficiency must fall short of $\frac{T_1 - T_2}{T_1}$.

The efficiency of the engine working in this way without compression is, however, much greater than is actually obtained in practice even when the same limits of temperature are employed, as will be seen in Art. 57.

54. Efficiency of an Engine working without Expansion.—

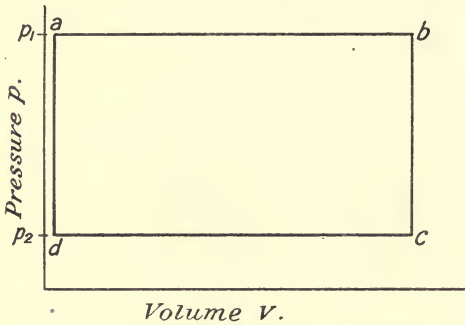

FIG. 31.—*p**v* diagram for non-expansion engine.

This was approximately done in the early Newcomen engine. Consider 1 pound of water at temperature T_2 . The indicator diagram is shown in Fig. 31. The water at “*d*” is heated to T_1 , being converted into steam and expanding along “*ab*” at pressure p_1 , it is then condensed along “*bc*” causing instantaneous fall in pressure until at “*d*” there is the original water at temperature T_2 and pressure p_2 .

$$\begin{aligned} \text{Heat taken in during stage “} ab \text{”} &= L_1 \dots \dots \dots (1) \\ \text{Heat rejected “} cd \text{”} &= h_1 - h_2 \dots \dots \dots (2) \\ \text{Work done during cycle} &= (p_1 - p_2)(V_s - V_w) \dots \dots \dots (3) \\ \text{Heat supplied} &= H_1 - h_2 \dots \dots \dots (4) \\ \text{Therefore efficiency} &= \frac{(p_1 - p_2)(V_s - V_w)}{J(H_1 - h_2)} \dots \dots \dots (5) \end{aligned}$$

In (3) and (5) V_s = volume of 1 pound of steam at pressure p_1
 V_w = “ “ “ “ water

In the above it is assumed that the cylinder, boiler, and condenser are all the same vessel; in practice the engine has separate organs, but the above equations still hold good. The separate operations being performed in separate vessels, the exhaust is rejected to a surface condenser, from which the water is returned by a feed pump to the boiler. Then for every pound of steam used non-expansively—

$$\begin{aligned} \text{the work done by the feed pump} &= (p_1 - p_2)V_w \\ \text{steam on the piston} &= (p_1 - p_2)V_s \end{aligned}$$

Hence the nett work done = $(p_1 - p_2)(V_s - V_w)$ as before.

The temperature-entropy diagram for this cycle is shown in Fig. 32. *da* represents the heating of the water from T_2 to T_1 ; *ab* the conversion of water into steam at constant temperature T_1 ; *bc* the condensation at constant volume due to the application of the condenser, the piston being at the end of its working stroke; *cd* the exhaust at constant temperature T_2 .

To draw the constant volume line *bc* draw the saturation curve *bg* for the steam, and draw any line *km* at temperature T between the temperatures T_1 and T_2 .

Let V be the volume of 1 pound of dry saturated steam at temperature

in an infinite number of instalments at temperatures ranging from T_2 to T_1 . In each little instalment the expression

$$\frac{T - T_2}{T}$$

represents the efficiency of the transformation into work of the small quantity of heat, say δQ , which is taken in by the working substance at any particular temperature T . The amount of heat converted into work is therefore for each instalment

$$\frac{\delta Q(T - T_2)}{T}$$

and the total quantity of heat converted into work will be

$$\sum \frac{\delta Q(T - T_2)}{T} \dots \dots \dots (1)$$

During this stage of the cycle the whole heat taken in is sensible from T_2 to T_1 , and equals $h_1 - h_2$. The whole heat taken in per pound of working substance is the sensible heat plus the latent heat at temperature T_1 .

Let L_1 = latent heat at temperature T_1 .

Then the total work done per pound of working substance, expressed in heat units is—

$$\begin{aligned} W &= \int_{T_2}^{T_1} dQ \frac{(T - T_2)}{T} + L_1 \frac{(T_1 - T_2)}{T_1} \\ &= \int_{T_2}^{T_1} dQ - T_2 \int_{h_2}^{h_1} \frac{dQ}{T} + L_1 \frac{(T_1 - T_2)}{T_1} \end{aligned}$$

this gives
$$W = h_1 - h_2 - T_2 \log_e \frac{T_1}{T_2} + L_1 \frac{(T_1 - T_2)}{T_1} \dots \dots (1)$$

Assuming the specific heat of water as being constant and equal to unity, in which case $dQ = dT$, writing $h_1 - h_2 = T_1 - T_2$, we have

$$W = (T_1 - T_2) - T_2 \log_e \frac{T_1}{T_2} + L_1 \frac{(T_1 - T_2)}{T_1}$$

or
$$W = (T_1 - T_2) \left(1 + \frac{L_1}{T_1} \right) - T_2 \log_e \frac{T_1}{T_2} \text{ heat units per lb. } \dots (2)$$

Now total heat supplied = $H_1 - h_2 = L_1 + h_1 - h_2 = L_1 + T_1 - T_2$

$$\therefore \text{efficiency} = \frac{(T_1 - T_2) \left(1 + \frac{L_1}{T_1} \right) - T_2 \log_e \frac{T_1}{T_2}}{L_1 + T_1 - T_2} \dots (3)$$

If the steam be initially wet, and of dryness fraction x_1 , the work done per pound becomes

$$W = T_1 - T_2 - T_2 \log_e \frac{T_1}{T_2} + x_1 L_1 \frac{(T_1 - T_2)}{T_1} \dots \dots (4)$$

or
$$W = (T_1 - T_2) \left(1 + \frac{x_1 L_1}{T_1} \right) - T_2 \log_e \frac{T_1}{T_2} \text{ heat units } \dots (5)$$

If the Fahrenheit units are used, W will be in B.Th.U.; with Centigrade units W will be expressed in C.H.U.

56. Derivation of the Adiabatic Equation from this Result.— Let x_1 lb. of water be raised from any temperature T_2 to T_1 , and let the fraction x_1 be evaporated at T_1 . Then—

$$\text{Heat taken in} = h_1 - h_2 + x_1 L_1 \quad \dots \quad (1)$$

By expanding adiabatically back to T_2 and *then condensing*, the work done by equation 4, Art. 55, is—

$$W = h_1 - h_2 - T_2 \log_{\epsilon} \frac{T_1}{T_2} - \frac{x_1 L_1 T_2}{T_1} + x_1 L_1$$

Subtracting the work done from the heat supplied we have

$$\begin{aligned} \text{Heat rejected} &= h_1 - h_2 + x_1 L_1 - \left(h_1 - h_2 - T_2 \log_{\epsilon} \frac{T_1}{T_2} - \frac{x_1 L_1 T_2}{T_1} + x_1 L_1 \right) \\ &= T_2 \log_{\epsilon} \frac{T_1}{T_2} + \frac{x_1 L_1 T_2}{T_1} \quad \dots \quad (2) \end{aligned}$$

Now all this rejection must occur during the final condensation, since the expansion is adiabatic, and the amount of heat so rejected = $x_2 L_2$, where x_2 = dryness fraction after expansion to T_2 .

$$\therefore x_2 L_2 = T_2 \log_{\epsilon} \frac{T_1}{T_2} + \frac{x_1 L_1 T_2}{T_1}$$

or
$$\frac{x_2 L_2}{T_2} = \frac{x_1 L_1}{T_1} + \log_{\epsilon} \frac{T_1}{T_2} \quad \dots \quad (3)$$

$$\therefore x_2 = \frac{T_2}{L_2} \left(\frac{x_1 L_1}{T_1} + \log_{\epsilon} \frac{T_1}{T_2} \right) \quad \dots \quad (4)$$

A result already obtained by a shorter method in Art. 46.

57. Temperature-Entropy Diagram for the Rankine-Clausius Cycle.—Commencing with one pound of water at temperature T_2 , represented by the point a on the diagram (Fig. 33), the water is heated to T_1 along the line ab , the gain of entropy being

$$fg = C_p \log_{\epsilon} \frac{T_1}{T_2} = \log_{\epsilon} \frac{T_1}{T_2} \quad (C_p \text{ for water being assumed unity})$$

The water at temperature T_1 is now turned into steam at T_1 along the line bc , the gain of entropy bc or gk being $\frac{L_1}{T_1}$, where L_1 is the latent heat at temperature T_1 . The steam then expands adiabatically along cd , down to the original temperature T_2 , and then condensation follows along da back to the original condition of water at temperature T_2 . The work done during the cycle is represented by the area

$abcd$

and the total amount of heat supplied is represented by the area

$fabck$

The efficiency of the cycle is therefore

$$\frac{\text{Heat converted into work}}{\text{Heat supplied}} = \frac{\text{area } abcd}{\text{area } fabck}$$

The area $abcd = \text{area } fabg - \text{area } falg + \text{area } lbcd$

$$= C_p(T_1 - T_2) - T_2 \times \log_e \frac{T_1}{T_2} + \frac{L_1}{T_1} \times (T_1 - T_2)$$

and taking $C_p = 1$

$$= (T_1 - T_2) \left(1 + \frac{L_1}{T_1} \right) - T_2 \log_e \frac{T_1}{T_2} \dots \dots (1)$$

a result already obtained in Art. 55.

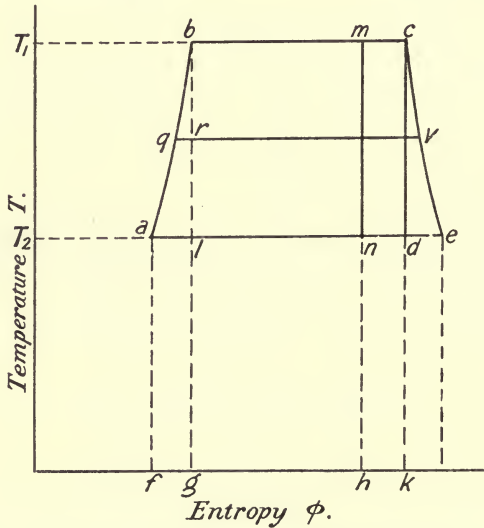

FIG. 33.— $T\phi$ diagram for Rankine cycle.

The area $abck = \text{area } fabg + \text{area } gbck$

$$= T_1 - T_2 + T_1 \times \frac{L_1}{T_1}$$

$$= L_1 + T_1 - T_2 \quad (\text{as in Art. 55}) \dots \dots (2)$$

The efficiency is therefore

$$\frac{(T_1 - T_2) \left(1 + \frac{L_1}{T_1} \right) - T_2 \log_e \frac{T_1}{T_2}}{L_1 + T_1 - T_2} \dots \dots (3)$$

which may also be written

$$1 - \frac{T_2 \left(\frac{L_1}{T_1} + \log \frac{T_1}{T_2} \right)}{L_1 + T_1 - T_2} \dots \dots (3A)$$

If the steam is initially wet, having dryness fraction $\frac{bm}{bc}$, the adiabatic expansion will take place along mn , and the work done per pound of steam will be represented by the area

$abmn$

and the total amount of heat supplied will be represented by the area

$$fabmh$$

the area $abmn = \text{area } fabg - \text{area } falg + \text{area } lbmn$

$$= (T_1 - T_2) - T_2 \times \log_{\epsilon} \frac{T_1}{T_2} + \frac{xL_1}{T_1} (T_1 - T_2)$$

$$= (T_1 - T_2) \left(1 + \frac{xL_1}{T_1} \right) - T_2 \log_{\epsilon} \frac{T_1}{T_2} \text{ (as in Art. 55) (4)}$$

the area $fabmh = \text{area } fabg + \text{area } gbmh$

$$= (T_1 - T_2) + T_1 \times \frac{xL_1}{T_1}$$

$$= xL_1 + T_1 - T_2 \dots \dots \dots (5)$$

The efficiency is therefore

$$\frac{(T_1 - T_2) \left(1 + \frac{xL_1}{T_1} \right) - T_2 \log_{\epsilon} \frac{T_1}{T_2}}{xL_1 + T_1 - T_2} \dots \dots \dots (6)$$

It will be seen from the diagram (Fig. 33) that the engine working on the Rankine-Clausius cycle does more work per pound of steam than the Carnot engine, the excess being represented by the area abl . To do this greater amount of work, however, the engine has to take in a proportionately greater amount of heat represented by the area $falg$, and is therefore less efficient, which fact has already been shown in Art. 53.

If now the entropy line ce for dry saturated steam be drawn, the dryness fraction of the steam at any point of the expansion can be found as in Art. 46, the dryness fraction at the end of the expansion being $\frac{ad}{ae}$.

For any other working fluid for which the specific heat of the liquid is s equation (1) becomes

$$\text{Work done per pound} = (T_1 - T_2) \left(s + \frac{L_1}{T_1} \right) - sT_2 \log_{\epsilon} \frac{T_1}{T_2} \dots (7)$$

and $\text{heat supplied} = L_1 + s(T_1 - T_2) \dots \dots \dots (8)$

The efficiency will therefore be

$$\frac{(T_1 - T_2) \left(s + \frac{L_1}{T_1} \right) - sT_2 \log_{\epsilon} \frac{T_1}{T_2}}{L_1 + s(T_1 - T_2)} \dots \dots \dots (9)$$

With the engine working on Carnot's cycle the final stage of operations is adiabatic compression from T_2 to T_1 . This is represented in Fig. 33 by the line lb , and it is obvious that the compression must be commenced when the steam has a dryness fraction $\frac{al}{ae}$.

Similarly the fraction $\frac{qr}{qv}$ represents the dryness fraction at any stage "r" of the adiabatic compression.

A comparison between the indicator ($p v$) diagram, and the temperature-entropy diagram for the Rankine cycle is given in Fig. 34. The curve BC represents the adiabatic expansion, and the dryness fraction of

the steam at any point of the expansion may also be shown on the "*pv*" diagram as follows :—

From B draw the curve for saturated steam BR $pv^{1.67} = \text{const.}$ (see Art. 70). Then at any point M on the expansion curve the dryness fraction is (neglecting the volume of the water)

$$x = \frac{GM}{GN} \text{ and on the entropy diagram } x = \frac{gm}{gn}$$

Suppose now the toe of the indicator diagram is cut off at E (it being uneconomical to expand below a certain pressure, as explained in Art. 53).

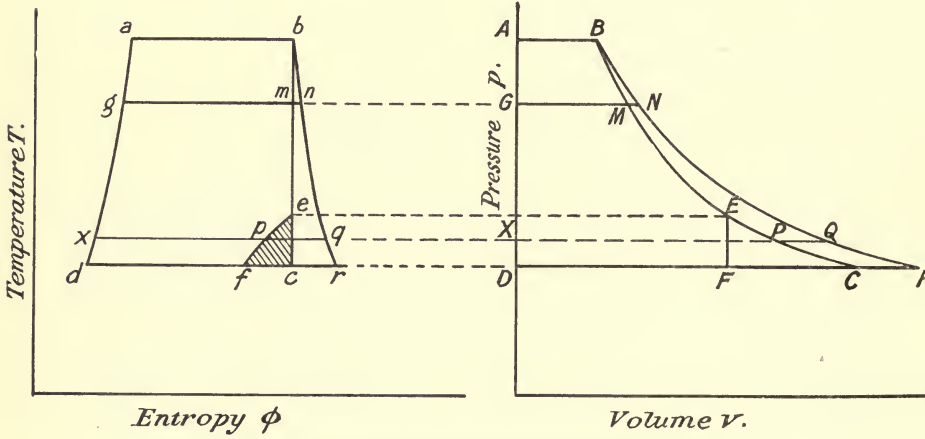

FIG. 34.—*pv* and *Tφ* diagram for the Rankine cycle.

This results in a sudden drop in pressure EF at *constant volume*. To show this loss, due to incomplete expansion, on the temperature-entropy diagram, take any point P on the *pv* diagram, and find a point "*p*" on the *Tφ* diagram such that $\frac{x_p}{x_q} = \frac{XP}{XQ}$. If this be repeated for several points between E and F, the curve "*epf*" is obtained on the *Tφ* diagram, the shaded area "*epfc*" representing the heat wasted by the incomplete expansion.

58. The effect of using Superheated Steam.—Let the steam be superheated to a temperature T_3 . Fig. 35 shows the *Tφ* diagram. The adiabatic expansion is now represented by the vertical line "*de*," and if the ratio of expansion is large enough (or what amounts to the same thing if the temperature of the superheat is not too high) the line "*de*" will cut the saturated steam line at some point *p*, at which point the steam will be just dry and saturated. Further expansion down to *e* results in wet steam of dryness $\frac{ae}{af}$. The total amount of work done per pound of superheated steam is represented by the area

$$abcde$$

the increase of work done due to superheating is represented by the area

gcde

The extra amount of heat which is supplied to obtain this increase of work done is represented by the area

mcdn

and the efficiency of this conversion of heat into work is given by

$$\frac{\text{area } gcde}{\text{area } mcdn}$$

which is greater than the efficiency using saturated steam, namely

$$\frac{\text{area } abcg}{\text{area } habcm}$$

because the additional heat "mcdn" is received at a much higher temperature than that at which the other portion of the heat is received.

Algebraic Expression for the Efficiency of an Engine using Superheated Steam and working on the Rankine-Clausius Cycle.—The total work done per pound of superheated steam is represented by the area

$$\begin{aligned} abcde &= \text{area } habk - \text{area } halk + \text{area } lbcg + \text{area } mcdn - \text{area } mgen \\ &= (T_1 - T_2) - T_2 \log_{\epsilon} \frac{T_1}{T_2} + (T_1 - T_2) \times \frac{L_1}{T_1} \\ &\quad + C_p(T_3 - T_1) - C_p T_2 \log_{\epsilon} \frac{T_3}{T_1} \\ &= (T_1 - T_2) \left(1 + \frac{L_1}{T_1} \right) - T_2 \log_{\epsilon} \frac{T_1}{T_2} + C_p(T_3 - T_1) - C_p T_2 \log_{\epsilon} \frac{T_3}{T_1} \\ &= (T_1 - T_2) \left(1 + \frac{L_1}{T_1} \right) + C_p(T_3 - T_1) - T_2 \left(\log_{\epsilon} \frac{T_1}{T_2} + C_p \log_{\epsilon} \frac{T_3}{T_1} \right) \quad (1) \end{aligned}$$

The total amount of heat supplied is represented by the area

$$\begin{aligned} habcdn &= \text{area } habcm + \text{area } mcdn \\ &= L_1 + (T_1 - T_2) + C_p(T_3 - T_1) \dots \dots \dots (2) \end{aligned}$$

The efficiency is therefore

$$\frac{(T_1 - T_2) \left(1 + \frac{L_1}{T_1} \right) + C_p(T_3 - T_1) - T_2 \left(\log_{\epsilon} \frac{T_1}{T_2} + C_p \log_{\epsilon} \frac{T_3}{T_1} \right)}{L_1 + T_1 - T_2 + C_p(T_3 - T_1)} \quad (3)$$

when C_p is the specific heat of steam at constant pressure.

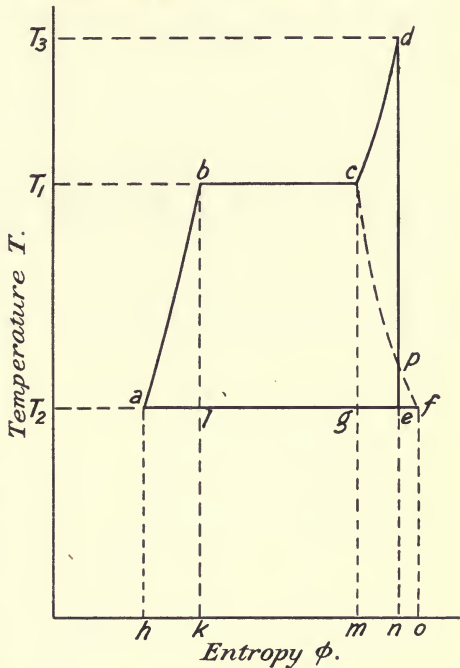

FIG. 35.— $T\phi$ diagram for engine using superheated steam on the Rankine cycle.

The efficiency is slightly greater than when saturated steam is used due to the widening of the temperature range. In actual practice, the use of superheated steam results in greater economy than the thermodynamic efficiency would lead one to expect, the advantage being rather in preventing initial condensation (see Chap. V.). The widening of the temperature range does not result (in the actual engine) in a corresponding increase of efficiency, for a greater part of the heat supplied is taken in at the temperature of saturation, and since its conversion into work depends upon the temperature at which it is taken in, it follows that the act of supplying a very much smaller quantity of heat afterwards, and so increasing the temperature range, will not materially increase the thermodynamic efficiency.

59. Engine in which the Steam is kept Dry and Saturated during Expansion.—This is partly secured in practice by applying a steam jacket to the engine cylinder. Steam jacketing, while never super-

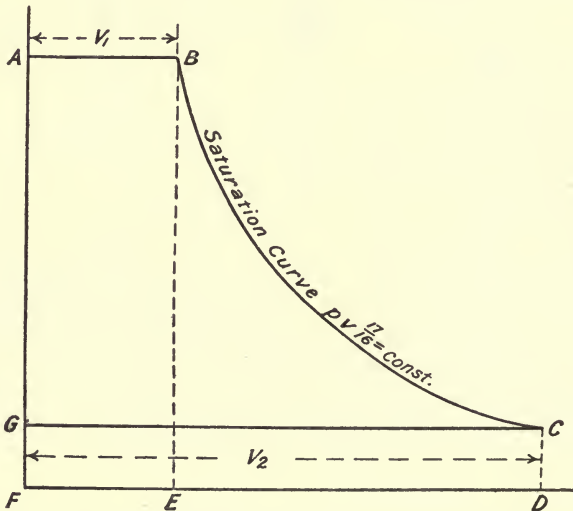

FIG. 36.—*p**v* diagram for engine when steam is kept dry and saturated during the expansion.

heating, tends to keep the steam dry and prevent condensation. The expansion curve, known as the saturation curve, follows the approximate law $p v^{17/16} = \text{constant}$. Fig. 36 shows the theoretical indicator diagram from which we see—

Work done during admission

$$= \text{area ABEF} = p_1 v_1 \dots \dots \dots (1)$$

Work done during expansion from v_1 to v_2

$$= \text{area BCDE} = \frac{p_1 v_1^{17/16} - p_2 v_2^{17/16}}{17/16 - 1} = 16(p_1 v_1 - p_2 v_2) \dots \dots (2)$$

Work expended during exhaust = area GCDF = $p_2 v_2$ (3)

∴ net amount of work done by the steam = $p_1 v_1 + 16(p_1 v_1 - p_2 v_2) - p_2 v_2$
 = $17(p_1 v_1 - p_2 v_2)$ (4)

Again—

Heat received from the boiler = $H_1 - h_2$ (5)

Heat rejected to the condenser = $H_2 - h_2$ (6)

Let H_j = heat supplied by the steam jacket

then $J(H_1 - H_2 + H_j) = 17(p_1 v_1 - p_2 v_2)$

or $H_j = \frac{17(p_1 v_1 - p_2 v_2)}{J} - (H_1 - H_2)$ (7)

and the efficiency is—

$$\frac{17(p_1 v_1 - p_2 v_2)}{J(H_1 - h_2 + H_j)} \dots \dots \dots (8)$$

Another method of considering this effect of the steam jacket is as follows:—

The temperature-entropy diagram for the ideal case is shown in Fig. 37, where, instead of the adiabatic “ce” on the Rankine cycle, the expansion follows the saturation curve “cd.” Hence the area “ced” represents the extra work done due to the heat supplied by the jacket.

To find the Heat supplied by the Jacket and the Efficiency of the Cycle.—Consider an element of the diagram *xy* of height dT . The area of this strip represents the work done δW over the small change in temperature dT .

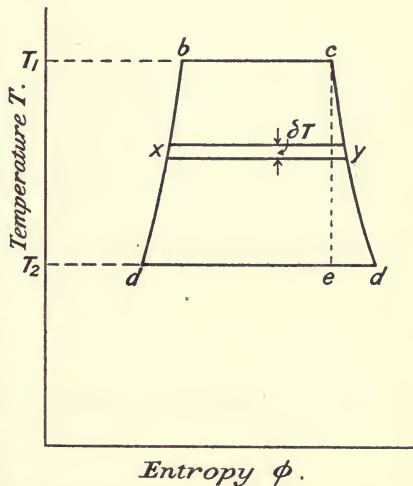

FIG. 37.— $T\phi$ diagram for engine when steam is kept dry and saturated during the expansion.

Let W = work done during the cycle

Then $\delta W = \frac{L}{T} dT$

$$\therefore W = \int_{T_2}^{T_1} \frac{L}{T} dT$$

Now $L = a - bT$ (Art. 35)

$$\therefore W = \int_{T_2}^{T_1} \frac{a - bT}{T} dT$$

$$= a \int_{T_2}^{T_1} \frac{dT}{T} - b \int_{T_2}^{T_1} dT$$

$$\therefore W = a \log_{\epsilon} \frac{T_1}{T_2} - b(T_1 - T_2) \dots \dots \dots (9)$$

Let H_1 = heat supplied at temperature T_1

H_j = „ „ by jacket

H_2 = heat rejected at absolute temperature T_2

h_1 = sensible heat at T_1

h_2 = „ „ T_2

then $W = H_1 + H_j - H_2 \dots \dots \dots (10)$

$\therefore H_j = W + H_2 - H_1$
 $= W + (L_2 + h_2) - (L_1 + h_1) = W + (h_2 - h_1) + L_2 - L_1$

Substituting for W , L_2 and L_1 we have

$$H_j = a \log_{\epsilon} \frac{T_1}{T_2} - b(T_1 - T_2) + (h_2 - h_1) + (a - bT_2) - (a - bT_1)$$

$$= a \log_{\epsilon} \frac{T_1}{T_2} - b(T_1 - T_2) + (h_2 - h_1) + b(T_1 - T_2)$$

$\therefore H_j = a \log_{\epsilon} \frac{T_1}{T_2} + h_2 - h_1$

$\therefore H_j = a \log_{\epsilon} \frac{T_1}{T_2} - (T_1 - T_2) \dots \dots \dots (11)$

Regarding the sensible heat of the exhaust h_2 as returnable, we can write—

$$\begin{aligned} \text{Nett heat supplied} &= H_1 + H_j - h_2 \\ &= L_1 + h_1 - h_2 + H \\ &= L_1 + T_1 - T_2 + H_j \dots \dots \dots (12) \end{aligned}$$

Substituting for H_j in (5) we have—

$$\begin{aligned} \text{Nett heat supplied} &= L_1 + T_1 - T_2 + a \log_{\epsilon} \frac{T_1}{T_2} - (T_1 - T_2) \\ &= L_1 + a \log_{\epsilon} \frac{T_1}{T_2} \dots \dots \dots (13) \end{aligned}$$

$$\begin{aligned} \therefore \text{Efficiency} &= \frac{W}{H_1 + H_j - h_2} \\ &= \frac{a \log_{\epsilon} \frac{T_1}{T_2} - b(T_1 - T_2)}{L_1 + a \log_{\epsilon} \frac{T_1}{T_2}} \dots \dots \dots (14) \end{aligned}$$

The numerical values of the constants “ a ” and “ b ” in (7) are $a = 1437$ and $b = 0.7$ when Fahrenheit units are used, and $a = 797$ and $b = 0.7$ when Centigrade units are employed.

EXAMPLE 1.—A steam engine using saturated steam works non-expansively, the initial pressure being 100 lbs. per square inch absolute ($t = 327.6^\circ$ F.) and the final pressure 15 lbs. per square inch absolute ($t = 213^\circ$ F.). Estimate its probable efficiency, given that the specific volume of steam at 100 lbs. is 4.34 cubic feet, and the volume of 1 lb. of water is 0.016 cubic foot.

By Art. 54, equation (5),

$$\text{efficiency} = \frac{(p_1 - p_2)(v_s - v_w)}{J(H_1 - h_2)}$$

To find H_1 and h_2

$$H_1 = 1082 + 0.3 \times 327.6 \\ = 1082 + 98.28 = 1180.28 \text{ B.Th.U.}$$

$$h_2 = 213 - 32 = 181 \text{ B.Th.U.}$$

$$\therefore \text{efficiency} = \frac{144(100 - 15)(4.34 - 0.016)}{778 \times (1180.28 - 181)} \\ = \frac{144 \times 85 \times 4.324}{778 \times 999.28} = 0.068 \text{ or } 6.8 \text{ per cent.}$$

N.B.—Note that the Carnot efficiency working between the same limits of temperature would be—

$$\frac{327.6 - 213}{327.6 + 461} = \frac{114.6}{788.6} = 0.145 \text{ or } 14.5 \text{ per cent.}$$

EXAMPLE 2.—If a steam engine works between the same pressures as in Example 1, but with complete adiabatic expansion, *i.e.* on the Rankine cycle, estimate its efficiency, the clearance being neglected.

The law of expansion is $p v^{1.135} = \text{constant}$.

$$\text{By (7) Art 53} \quad \text{efficiency} = \frac{\frac{n}{n-1}(p_1 v_1 - p_2 r v_1) - (p_1 - p_2)V_w}{J(H_1 - h_2)}$$

To find the ratio of expansion " r "

$$\text{Since} \quad p_1 v_1^{1.135} = p_2 v_2^{1.135} \\ \therefore \frac{p_1}{p_2} = \left(\frac{v_2}{v_1}\right)^{1.135} = r^{1.135}$$

$$\therefore 1.135 \log r = \log 100 - \log 15 = 2.000 - 1.1761 = 0.8239$$

$$\therefore \log r = \frac{0.8239}{1.135} = 0.7259$$

$$\therefore r = 5.32$$

\therefore efficiency

$$= \frac{1.135}{0.135} (100 \times 144 \times 4.34 - 15 \times 144 \times 5.32 \times 4.34) - (100 - 15)144 \times 0.016 \\ \hline 778(1180.28 - 181)$$

$$= \frac{8.33 \times 4.34(100 - 79.8)144 - 1.36 \times 144}{778 \times 999.28}$$

$$= \frac{(8.33 \times 4.34 \times 20.2 - 1.36)144}{778 \times 999.28} = \frac{(730.23 - 1.36)144}{778 \times 999.28}$$

$$= \frac{104,960}{778 \times 999.28} = 0.135 \text{ or } 13 \text{ per cent.}$$

The above result may be checked by the expression for the Rankine efficiency (Art. 55, equation 3)—

$$\text{efficiency} = \frac{(T_1 - T_2)\left(1 + \frac{L_1}{T_1}\right) - T_2 \log_e \frac{T_1}{T_2}}{L_1 + T_1 - T_2}$$

$$\begin{aligned}\text{Now } L_1 &= 1114 - 0.7 \times 327.6 = 1114 - 229.3 = 884.7 \\ T_1 &= 327.6 + 461 = 788.6^\circ \\ T_2 &= 213 + 461 = 674^\circ\end{aligned}$$

Substituting these values we get—

$$\begin{aligned}\text{efficiency } \eta &= \frac{1114.6 \left(1 + \frac{884.7}{788.6} \right) - 674 \times 2.303 \times \log_{10} \frac{788.6}{674}}{999.28} \\ &= \frac{1114.6 \times 2.121 - 674 \times 2.303 \times (2.8968 - 2.8287)}{999.28} \\ &= \frac{243.06 - 674 \times 2.303 \times 0.0681}{999.28} \\ &= \frac{243.06 - 105.7}{999.28} \\ &= \frac{137.36}{999.28} = 0.137 \text{ or } 13.7 \text{ per cent.}\end{aligned}$$

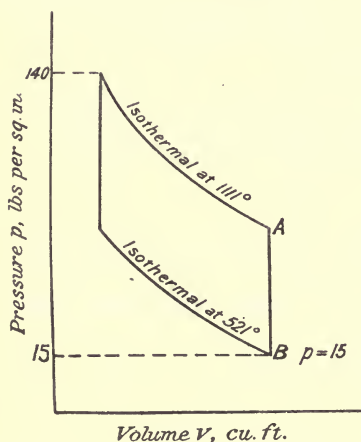

FIG. 38.

EXAMPLE 3.—In a Stirling's engine, fitted with a perfect regenerator, the maximum pressure is 140 lbs. per square inch absolute and the minimum 15 lbs. per square inch absolute, the upper and lower temperatures being 650° F. and 60° F. A perfectly reversible steam engine uses dry saturated steam between the same limits of pressure. Compare their efficiencies, and if the piston speed and stroke be the same in each engine, compare the diameters of the cylinders for equal power.

Given temperature of saturation at 160 lbs. abs. = 352° F., and at 15 lbs. abs. = 213° F., and specific volume at 15 lbs. abs. = 25.85.

Stirling engine—

$$\text{Efficiency} = \frac{650 - 60}{650 + 461} = \frac{590}{1111} = 0.531 \text{ or } 53.1 \text{ per cent.}$$

Steam engine—

$$\text{Efficiency} = \frac{352.8 - 213}{352.8 + 461} = \frac{139.8}{813.8} = 0.171 \text{ or } 17.1 \text{ per cent.}$$

Since the piston speeds and strokes are the same, the ratio of the areas of the cylinders will be inversely as the ratio of the mean effective pressures for equal power.

To find the mean effective pressures (P_m).

Stirling engine: $T_1 = 1111^\circ$; $T_2 = 521^\circ$.

The indicator diagram is shown in Fig. 38.

Let p_A = pressure at point A at the end of expansion

Then $p_A = p_B \times \frac{1111}{521} = 15 \times \frac{1111}{521} = 31.98$ (say 32 lbs. per square inch)

Now $p_1 v_1 = p_2 v_2$

$$\therefore \frac{v_2}{v_1} = r = \frac{p_1}{p_2} = \frac{140}{32} = 4.37$$

$$\begin{aligned} \therefore p_m &= \frac{\text{area of diagram}}{\text{length of diagram}} = \frac{p_1 v_1 \log_e r - p_2 v_2 \log_e r}{v_2 - v_1} \\ &= \frac{140 v_1 \log_e r - 15 \times 4.37 v_1 \log_e r}{4.37 v_1 - v_1} = \frac{v_1 (140 - 15 \times 4.37) \log_e 4.37}{4.37 v_1 - v_1} \end{aligned}$$

$$\begin{aligned} \therefore p_m &= \frac{140 - 65.55}{3.37} \times 2.303 \times 0.6405 \\ &= \frac{74.45 \times 2.303 \times 0.6405}{3.37} = \frac{109.818}{3.37} = 32.58 \text{ lbs. per sq. inch} \end{aligned}$$

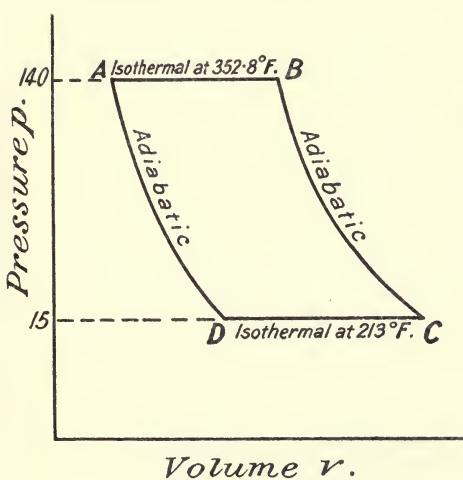

FIG. 39.

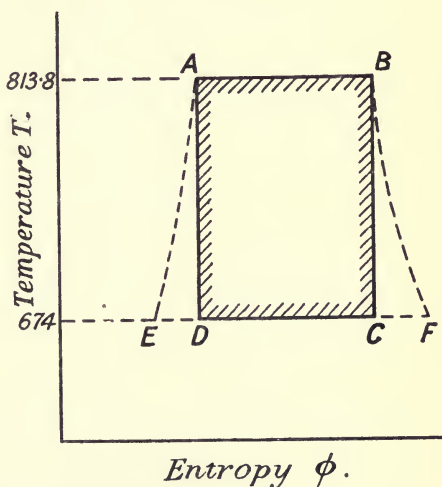

FIG. 40.

Steam engine: $T_1 = 813.8^\circ$; $T_2 = 674^\circ$.

The indicator diagram is shown in Fig. 39 and the $T\phi$ diagram in Fig. 40. The length of the diagram will be the volume at point C after adiabatic expansion.

Let x_2 = dryness fraction after expansion.

Then length of diagram = $25.85 \times x_2$.

To find x_2 .—For adiabatic expansion we have the equation

$$x_2 = \frac{T_2}{L_2} \left(\frac{L_1}{T_1} + \log_e \frac{T_1}{T_2} \right)$$

$$L_1 = 1114 - 0.7 \times 352.8 = 1114 - 246.96 = 867.04 \text{ B.Th.U.}$$

$$L_2 = 1114 - 0.7 \times 213 = 1114 - 149.1 = 964.9 \text{ B.Th.U.}$$

$$\begin{aligned} \therefore x_2 &= \frac{674}{964.9} \left(\frac{867.04}{813.8} + 2.303 \times \log_{10} \frac{813.8}{674} \right) \\ &= \frac{674}{964.9} \left\{ \frac{867.04}{813.8} + 2.303(2.9105 - 2.8287) \right\} \\ &= \frac{674}{964.9} (1.065 + 0.188) = \frac{674 \times 1.253}{964.9} = 0.866. \end{aligned}$$

x_2 may also be found directly from the $T\phi$ diagram, *i.e.* $x_2 = \frac{EC}{EF}$ (Fig. 40).

\therefore neglecting the volume of the water, the volume after expansion is $25.85 \times 0.866 = 22.38$ cubic feet.

Work done = area of $T\phi$ diagram ABCD

$$= \frac{778}{144} (813.8 - 674) \times \frac{867.04}{813.8} \text{ foot-pounds}$$

$$\begin{aligned} \therefore p_m &= \frac{778 \times 139.8 \times \frac{867.04}{873.8}}{22.38 \times 144} \\ &= \frac{778 \times 139.8 \times 1.065}{22.38 \times 144} = 35.96 \text{ lbs. per square inch absolute.} \end{aligned}$$

Hence

$$\begin{aligned} \frac{\text{area of Stirling}}{\text{area of steam}} &= \frac{35.96}{32.58} = \frac{1.073}{1} \\ \therefore \frac{\text{diameter of Stirling}}{\text{diameter of steam}} &= \sqrt{1.073W} = \frac{1.03}{1} \end{aligned}$$

EXAMPLE 4.—An engine is fitted with steam jackets so that the steam remains dry and saturated throughout the expansion. If the initial temperature is 400° F. and the final back-pressure temperature is 126° F., calculate the heat supplied by the jacket per lb. of steam, and the efficiency of the engine.

$$T_1 = 400 + 461 = 861$$

$$T_2 = 126 + 461 = 587$$

$$H_j = 1437 \log_e \frac{T_1}{T_2} - (T_1 - T_2) \quad (\text{Art. 59, equation (11)})$$

$$= 1437 \times 2.303(2.9350 - 2.7686) - (861 - 587)$$

$$= 550.7 - 274$$

$$\therefore H_j = 276.7 \text{ B.Th.U.}$$

$$\text{The efficiency by equation (14), Art. 59} = \frac{a \log_e \frac{T_1}{T_2} - b(T_1 - T_2)}{L_1 + a \log_e \frac{T_1}{T_2}}$$

$$\text{Now } L_1 = 1114 - 0.7 \times 400 = 1114 - 280 = 834 \text{ B.Th.U.}$$

Substituting we get

$$\text{Efficiency} = \frac{550.7 - 0.7 \times 274}{834 + 550.7} = \frac{550.7 - 191.8}{834 + 550.7}$$

$$= \frac{358.9}{1384.7} = 0.259 \text{ or } 25.9 \text{ per cent.}$$

60. The Regenerative Steam Engine.—It has been shown in Art. 57 that the efficiency of the Rankine cycle is always less than the ideal $\frac{T_1 - T_2}{T_1}$ of the reversible Carnot cycle. The efficiency of the steam-engine cycle may, however, be increased, and may then approximate to the ideal value of the perfectly reversible heat engine. The principle of regenerative feed-heating is exactly the same as that invented by Dr. Stirling and described in Art. 27. Heat is abstracted from the working steam at one or more stages during expansion by the feed water on its way to the boiler. In the ideal case the number of stages will be infinite, and the feed water will enter the boiler at the same temperature as the boiler steam, the temperature-entropy diagram being the same as that of the Stirling cycle with perfect regenerator (Fig. 8).

The complete temperature-entropy diagram of the ideal regenerative steam-engine cycle is shown in Fig. 41. During the expansion from T_1 to T_2 along cd , an amount of heat represented by the area $dchg$ is abstracted from the working steam in order to heat the feed water on its way to the boiler. The heat necessary to raise the temperature of 1 pound of feed water from T_2 to T_1 is represented by the area $abfe$; hence, since in the ideal case under consideration there are no losses, the areas $dchg$ and $abfe$ are equal. The area $fbch$ represents the latent heat (L_1) taken in during evaporation at the constant temperature T_1 , and the area $eadg$ represents the quantity of heat (H_2) rejected to the condenser.

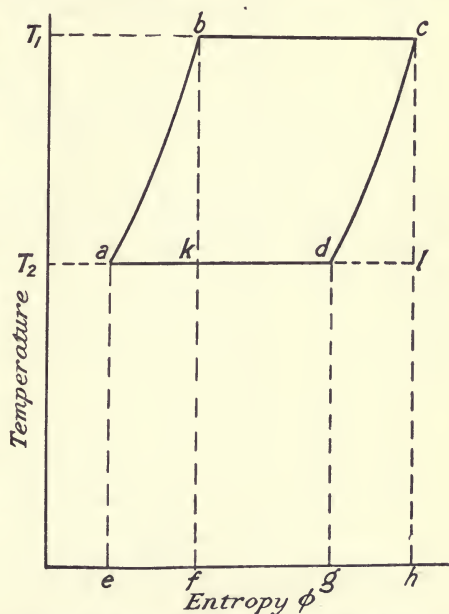

FIG. 41.— $T\phi$ diagram for ideal regenerative cycle.

Since the area $abfe$ is equal to the area $dchg$ it follows that the net amount of heat taken in is represented by the area $fbch$; the efficiency, therefore, will be—

$$\begin{aligned} & \frac{\text{heat converted into work}}{\text{net amount of heat taken in}} \\ &= \frac{\text{net amount of heat taken in} - \text{heat rejected to the condenser}}{\text{net amount of heat taken in}} \\ &= \frac{\text{area } fbch - \text{area } eadg}{\text{area } fbch} \\ &= \frac{\text{area } abcd}{\text{area } fbch} \end{aligned}$$

and for w pound working between T_1 and T_3

$$w \log_{\epsilon} \frac{T_1}{T_3} + w \frac{L_1}{T_1} - \frac{R}{T_3} = 0 \dots \dots \dots (3)$$

Also since 1 pound of the feed is heated from T_2 to T_3 by w pound of receiver steam

$$R = T_3 - T_2 \dots \dots \dots (4)$$

Hence from (3)

$$w = \frac{\frac{R}{T_3}}{\log_{\epsilon} \frac{T_1}{T_3} + \frac{L_1}{T_1}}$$

and from (4)

$$w = \frac{1 - \frac{T_2}{T_3}}{\log_{\epsilon} \frac{T_1}{T_3} + \frac{L_1}{T_1}} \dots \dots \dots (5)$$

Also the work done will be

$$W = \text{heat received} - \text{heat rejected} \\ = (1 + w)(L_1 + T_1 - T_3) - H_2 \dots \dots \dots (6)$$

Hence the efficiency will be

$$\eta = \frac{(1 + w)(L_1 + T_1 - T_3) - H_2}{(1 + w)(L_1 + T_1 - T_3)} \dots \dots \dots (7)$$

Substituting in (7) the value of H_2 from (2) we get

$$\eta = \frac{(1 + w)(L_1 + T_1 - T_3) - T_2 \left\{ \log_{\epsilon} \frac{T_1}{T_2} + \frac{L_1}{T_1} \right\}}{(1 + w)(L_1 + T_1 - T_3)} \\ = 1 - \frac{1}{1 + w} \cdot \frac{T_2 \left(\log_{\epsilon} \frac{T_1}{T_2} + \frac{L_1}{T_1} \right)}{L_1 + T_1 - T_3} \dots \dots \dots (8)$$

which is always greater than the efficiency of the Rankine cycle, Art. 57, equation (3A). In the above theory it is assumed that the feed water abstracts as much heat from the receiver steam as it can, in order that its temperature may be raised from T_2 to T_3 . Actually the efficiency will be a little less than that obtained by substituting the value of w from (5) in (8), because the resulting temperature of the feed water will be less than T_3 .

Triple-Expansion Engine.—The regenerative principle may also be applied to the triple-expansion engine, the ideal cycle for which is shown on the temperature-entropy diagram (Fig. 43). *cm* is the curve of perfect regeneration, *cd* expansion in the high-pressure cylinder, *fg* expansion in the intermediate cylinder, and *kn* the expansion in the low-pressure cylinder. The gross amount of heat supplied is represented by the area *cabch*, and since an amount of heat represented by the area *lkgfdh* is returned to the feed, the net amount of heat supplied is shown by the area *abcdfgkl*. The work done is represented by the shaded area, and the efficiency is—

$$\eta = \frac{\text{area } abcdfgkn}{\text{area } abcdfgkl}$$

Let w_1 = weight of steam taken from the first receiver, between the high-pressure and intermediate cylinders, and T_1' its temperature.

R_1 = heat supplied to the feed from w_1 .

w_2 = weight of steam taken from the second receiver between the intermediate and low-pressure cylinders, and T_2' its temperature.

R_2 = heat supplied to the feed from w_2 .

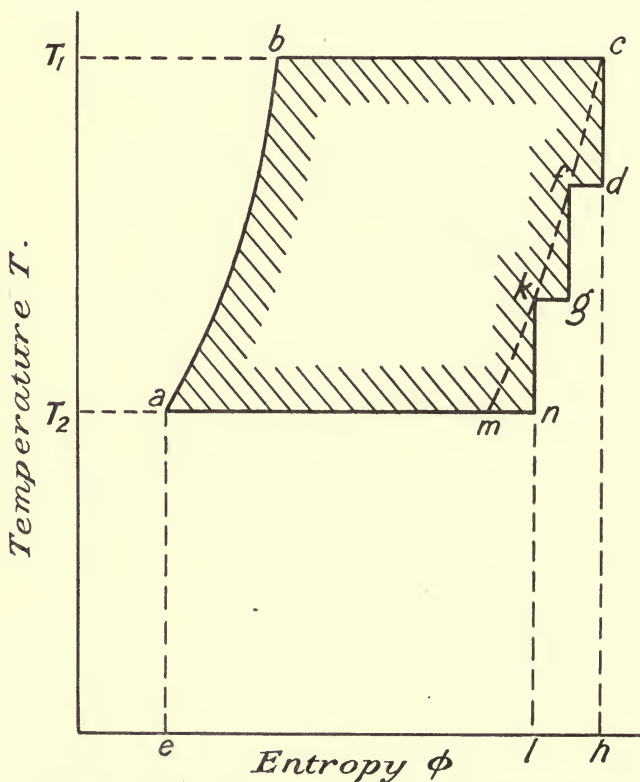

FIG. 43.— $T\phi$ diagram for triple-expansion regenerative cycle.

Then for each pound of steam passing completely through the engine we have

For 1 pound of steam working between T_1 and T_2

$$\log_{\epsilon} \frac{T_1}{T_2} + \frac{L_1}{T_1} - \frac{H_2}{T_2} = 0 \quad \dots \dots \dots (9)$$

For w_1 pound working between T_1 and T_1'

$$w_1 \log_{\epsilon} \frac{T_1}{T_1'} + w_1 \frac{L_1}{T_1} - \frac{R_1}{T_1'} = 0 \quad \dots \dots \dots (10)$$

For w_2 working between T_1 and T_2'

$$w_2 \log_e \frac{T_1}{T_2'} + w_2 \frac{L_1}{T_1} - \frac{R_2}{T_2'} = 0 \quad \dots \quad (11)$$

$$R_2 = T_2' - T_2 \quad \dots \quad (12)$$

$$R_1 = (1 + w_2)(T_1' - T_2') \quad \dots \quad (13)$$

Hence from (11) and (12)

$$w_2 = \frac{1 - \frac{T_2}{T_2'}}{\log_e \frac{T_1}{T_2'} + \frac{L_1}{T_1}} \quad \dots \quad (14)$$

From (10) and (13)

$$w_1 = \frac{(1 + w_2) \left(1 - \frac{T_2'}{T_1'}\right)}{\log_e \frac{T_1}{T_1'} + \frac{L_1}{T_1}} \quad \dots \quad (15)$$

The work done (shaded area) per pound of steam passing through the condenser, or per $(1 + w_1 + w_2)$ pound passing from the boiler through the high-pressure cylinder, is

$$\begin{aligned} W &= (1 + w_1 + w_2)(L_1 + T_1 - T_1') - H_2 \\ &= (1 + w_1 + w_2)(L_1 + T_1 - T_1') - T_2 \left(\log_e \frac{T_1}{T_2} + \frac{L_1}{T_1} \right) \end{aligned} \quad (16)$$

and the efficiency

$$\begin{aligned} \eta &= \frac{W}{(1 + w_1 + w_2)(L_1 + T_1 - T_1')} \\ &= 1 - \frac{T_2 \left(\log_e \frac{T_1}{T_2} + \frac{L_1}{T_1} \right)}{(1 + w_1 + w_2)(L_1 + T_1 - T_1')} \quad \dots \quad (17) \end{aligned}$$

In practice this complete cycle is not carried out: Mr. Weir only takes steam from the low-pressure receiver, in which case $w_1 = 0$ and equations (14) and (17) reduce to the same as (5) and (8).

EXAMPLE.—In a compound steam engine, the admission pressure to the high-pressure cylinder is 150 pounds per square inch absolute, and the exhaust pressure in the low-pressure cylinder is 4 pounds per square inch absolute. The back pressure in the high-pressure cylinder and the admission pressure of the low-pressure cylinder is 45 pounds absolute. Steam for feed heating is drawn from the low-pressure steam chest. Assuming complete adiabatic expansion and no heat losses, estimate the efficiency of the engine, and the gain due to feed heating.

From steam tables we find,

at 150 pounds absolute	$L_1 = 863$ and	$T_1 = 358 + 460 = 818$
" 45 " "	"	$T_3 = 274 + 460 = 734$
" 4 " "	"	$T_2 = 153 + 460 = 613$

From (5)

$$w = \frac{1 - \frac{613}{734}}{\log_e \frac{818}{734} + \frac{863}{818}} = \frac{1 - 0.8351}{0.1084 + 1.0550}$$

$$w = \frac{0.1649}{1.1634} = 0.1417 \text{ pound}$$

and from (8)

$$\eta = 1 - \frac{613 (\log_e \frac{818}{613} + \frac{863}{818})}{1.1417(863 + 818 - 734)}$$

$$= 1 - \frac{613(0.2885 + 1.0550)}{1.1417 \times 947}$$

$$= 1 - 0.761$$

$$= 0.239 \text{ or } 23.9 \text{ per cent.}$$

Without feed heating and working on the Rankine cycle between temperature limits T_1 and T_2 the efficiency will be by (5A), Art. 57,

$$1 - \frac{613(\log_e \frac{818}{613} + \frac{863}{818})}{863 + 818 - 613}$$

$$= 1 - 0.772$$

$$= 0.228 \text{ or } 22.8 \text{ per cent.}$$

The increased efficiency due to feed heating is therefore $23.9 - 22.8 = 1.1$ per cent., or the percentage saving is $100 \times \frac{1.1}{22.8} = 4.8$ per cent.

61. The Expansion Curve to be assumed in estimating the

probable Indicated Horse-Power of Steam Engines.—

When dry saturated steam is admitted into the cylinder the pressure will not remain constant up to the point of cut-off, but falls during admission due to wire-drawing and initial condensation. When cut-off occurs the pressure drops quickly for a portion of the stroke, due probably to further condensation, and then some of the previously condensed steam re-evaporates during the latter portion of the stroke and so keeps the pressure up higher than if there had been no initial condensation. The result is that the expansion curve follows neither the adiabatic nor the saturation curve, being less steep than either of them, approaching very closely to the isothermal for a gas, the curve being approximately a rectilinear hyperbola.

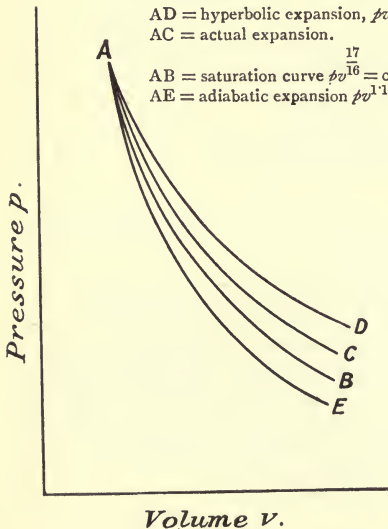

FIG. 44.

Fig. 44 shows approximately the shapes of these three curves. The

expansion curve, which is always taken for approximate calculations on the probable indicated horse-power, is the hyperbola, hyperbolic expansion ($p v = \text{constant}$) being assumed. Fig. 45 shows the assumed theoretical indicator diagram.

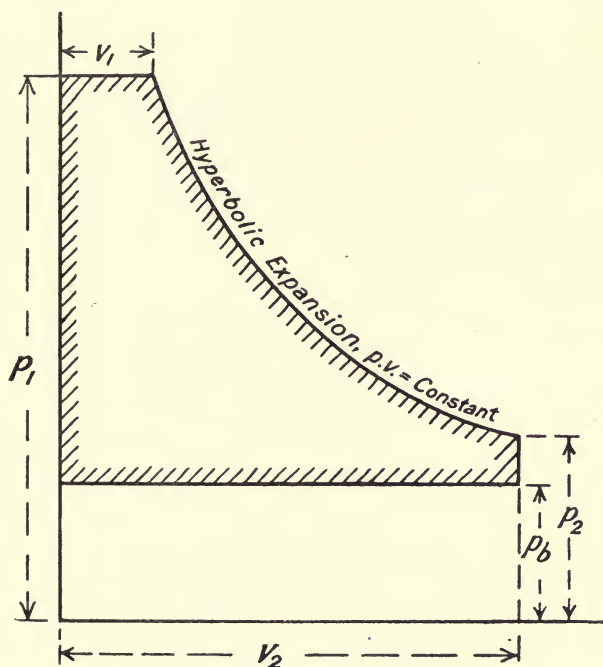

FIG. 45.—Theoretical indicator diagram.

Let p_1 = initial pressure in lbs. per square inch absolute.
 p_2 = pressure after expansion in lbs. per square inch absolute.
 p_b = back pressure in lbs. per square inch absolute.
 v_1 = initial volume in cubic feet } then $\frac{v_2}{v_1} = r$
 v_2 = final volume
 r = ratio of expansion.

Then work done is represented by the shaded area

= work done during admission + work during expansion
 - work during exhaust

$$\therefore W = 144(p_1 v_1 + p_1 v_1 \log_e r - p_b v_2) \text{ ft.-lbs.} \quad \dots \quad (1)$$

and mean effective pressure

$$\begin{aligned} p_m &= \frac{p_1 v_1 + p_1 v_1 \log_e r - p_b v_2}{v_2} = \frac{p_1 v_1}{v_2} (1 + \log_e r) - p_b \\ &= \frac{p_1}{r} (1 + \log_e r) - p_b \quad \dots \quad (2) \end{aligned}$$

Equation (2) gives the theoretical mean effective pressure in terms of

the initial pressure, ratio of expansion, and the back pressure, all pressures being in lbs. per square inch. In practice, since a sharp cut-off cannot be obtained, and also because of the rounding off of the diagram at release and the compression, the mean effective pressure is always less than the ideal given by (2) and may be written

$$p_m = e \left\{ \frac{p_1}{r} (1 + \log_e r) - p_b \right\} \dots \dots \dots (3)$$

where e = a constant less than unity, and called by Professor Unwin "the diagram factor."

- If L = length of stroke in feet,
- A = area of cylinder in square inches,
- N = number of working strokes per minute,

then the indicated horse-power—

$$\text{I.H.P.} = \frac{p_m LAN}{33,000} \dots \dots \dots (4)$$

Engine using Superheated Steam.—In this case the law of the expansion curve being $p v^n = \text{constant}$, we have

$$W = p_1 v_1 + \frac{p_1 v_1}{n-1} \left\{ 1 - \left(\frac{v_1}{v_2} \right)^{n-1} \right\} - p_b v_2 \dots \dots (5)$$

$$= p_1 v_1 + \frac{p_1 v_1}{n-1} \left\{ 1 - \left(\frac{1}{r} \right)^{n-1} \right\} - p_b v_2 \dots \dots (6)$$

Now the work done is also equal to $p_m \times v_2$

$$\therefore p_m v_2 = p_1 v_1 + \frac{p_1 v_1}{n-1} \left\{ 1 - \left(\frac{1}{r} \right)^{n-1} \right\} - p_b v_2$$

$$\therefore p_m = p_1 \frac{v_1}{v_2} + \frac{p_1 v_1}{(n-1)v_2} \left\{ 1 - \left(\frac{1}{r} \right)^{n-1} \right\} - p_b \frac{v_2}{v_2}$$

$$= \frac{p_1}{r} + \frac{p_1}{r(n-1)} \left\{ 1 - \left(\frac{1}{r} \right)^{n-1} \right\} - p_b$$

$$= \frac{p_1}{n-1} \left\{ \frac{n-1}{r} + \frac{1}{r} - \left(\frac{1}{r} \right)^n \right\} - p_b$$

$$\therefore p_m = \frac{p_1}{n-1} \left\{ \frac{n}{r} - \frac{1}{r^n} \right\} - p_b \dots \dots \dots (7)$$

For superheated steam the value of "n" is 1.3 and substituting this value in (3) will give p_m ; for dry saturated steam $n = 1.135$, and for steam which is kept dry during expansion $n = \frac{17}{16} = 1.0646$.

62. Effect of Clearance on the Mean Effective Pressure.—In actual practice the piston does not come right up to the end of the cylinder at the end of the exhaust stroke, a small space being left to allow for the wear of the bearings and other mechanical reasons. In addition, there is the volume of the steam ports between the cylinder and valve face. This total volume is called the *clearance* volume, and must be taken into account in all calculations on the curves of expansion. It constitutes a volume through which the piston does not sweep, but which is always filled with steam when admission occurs, and this steam in the clearance space forms part of the total steam which expands after cut-off. The

theoretical indicator diagram as modified by the clearance is shown in Fig. 46. As will be seen, it results in a higher mean effective pressure, and a lower ratio of expansion than is obtained when the clearance is neglected.

Let r = ratio of expansion when clearance is neglected.

R = true ratio of expansion (allowing for clearance).

c = fraction of piston displacement representing clearance.

$$\begin{aligned} \text{Then } R &= \frac{\text{final volume}}{\text{initial volume}} = \frac{v_2 + \text{clearance}}{v_1 + \text{clearance}} \\ &= \frac{\text{volume of piston displacement} + \text{clearance}}{\text{volume to point of cut-off} + \text{clearance}} = \frac{v_2 + cv_2}{v_1 + cv_2} \end{aligned}$$

$$\therefore R = \frac{1 + c}{\frac{1}{r} + c} = \frac{r(1 + c)}{1 + cr} \quad (1)$$

This value of R must be substituted for " r " in equation (3) and equation (7), Art. 61, when estimating the mean effective pressure.

To obtain an expression for the mean effective pressure in a single cylinder engine in terms of the initial pressure, p_1 lbs. per square inch absolute, the back pressure p_b lbs. per square inch absolute, the ratio of expansion neglecting clearance " r ," the clearance volume being c times the piston displacement.

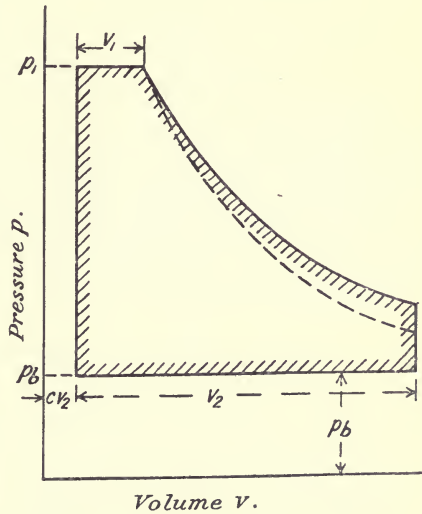

FIG. 46.—Theoretical induction diagram modified by clearance.

W = shaded area (Fig. 46)

$$\begin{aligned} &= p_1 v_1 - p_b v_2 + p_1 (v_1 + cv_2) \log_e R \\ &= p_1 v_1 - p_b v_2 + p_1 (v_1 + cv_2) \log_e \frac{1 + c}{\frac{1}{r} + c} \quad (\text{by } (1)) \end{aligned}$$

$$\therefore p_m = \frac{p_1 v_1 - p_b v_2 + p_1 (v_1 + cv_2) \log_e \frac{1 + c}{\frac{1}{r} + c}}{v_2} \quad \dots (2)$$

$$= \frac{p_1}{r} - p_b + p_1 \left(\frac{1}{r} + c \right) \log_e \frac{1 + c}{\frac{1}{r} + c}$$

$$\therefore p_m = \frac{p_1}{r} \left\{ 1 + (1 + cr) \log_e \frac{1 + c}{\frac{1}{r} + c} \right\} - p_b \quad \dots (3)$$

If the expansion follows the general law $p v^n = \text{constant}$, (6), Art. 61, becomes:—

$$\begin{aligned}
 W &= p_1 v_1 + \frac{p_1(v_1 + c v_2)}{n-1} \left\{ 1 - \left(\frac{1}{r+c} \right)^{n-1} \right\} - p_b v_2 \quad \dots (4) \\
 \therefore p_m &= \frac{p_1}{r} + \frac{p_1(v_1 + c v_2)}{v_2(n-1)} \left\{ 1 - \left(\frac{1}{r+c} \right)^{n-1} \right\} - p_b \\
 &= \frac{p_1}{n-1} \left[\frac{n-1}{r} + \frac{v_1 + c v_2}{v_2} \left\{ 1 - \left(\frac{1}{r+c} \right)^{n-1} \right\} \right] - p_b \\
 \therefore p_m &= \frac{p_1}{n-1} \left\{ n + c - \frac{\left(\frac{1}{r+c} \right)^n}{\left(\frac{1}{r+c} \right)^{n-1}} \right\} - p_b \quad \dots \dots \dots (5)
 \end{aligned}$$

EXAMPLE 1.—The diameter of a steam-engine cylinder is 6 inches and the stroke 12 inches. If the initial pressure is 100 lbs. per square inch absolute and cut-off is $\frac{1}{4}$ stroke, find the mean effective pressure, neglecting clearance, the back pressure being 3 lbs. per square inch absolute.

If the clearance is $\frac{1}{10}$ of the piston displacement, find the probable I.H.P. if there are 400 working strokes per minute (*i.e.* the engine is double-acting and runs at 200 revolutions per minute).

Obviously $r = 4$.

$$\begin{aligned}
 p_m &= \frac{100}{4} (1 + \log_e 4) - 3 \\
 &= 25(1 + 1.3862) - 3 \\
 &= 25 \times 2.3862 - 3 = 59.65 - 3 = 56.65 \text{ lbs. per sq. in.}
 \end{aligned}$$

$$\text{The actual ratio } R = \frac{0.25 + 0.1}{1 + 0.1} = \frac{0.35}{1.1} = 3.18$$

$$\begin{aligned}
 \therefore p_m &= \frac{100}{3.18} (1 + \log_e 3.18) - 3 \\
 &= \frac{100}{3.18} (1 + 1.1555) - 3 = \frac{100 \times 2.1555}{3.18} - 3 \\
 &= 68 - 3 \\
 &= 65 \text{ lbs. per square inch}
 \end{aligned}$$

$$\therefore \text{I.H.P.} = \frac{65 \times \pi \times (0.7854 \times 36) \times 400}{33,000} = 22.4$$

EXAMPLE 2.—Find the diameter of the steam-engine cylinder needed to develop 100 I.H.P. when the piston speed is 600 feet per minute, initial steam pressure 150 lbs. per square inch absolute, back pressure 15 lbs. per square inch absolute, cut-off $\frac{1}{5}$ of stroke, clearance volume 8 per cent. of piston displacement, and the effect of early release, compression, etc., reduces the actual mean effective pressure to 90 per cent. of the theoretical.

$$p_m = \frac{p_1}{r} \left\{ 1 + (1 + cr) \log_e \frac{1+c}{1+c} \right\} - p_b \quad ((3) \text{ Art. } 62)$$

Here $r = 5$, $c = 0.08$

$$\begin{aligned} \therefore p_m &= \frac{150}{5} \left\{ 1 + (1 + 0.08 \times 5) \log_e \frac{1.08}{\frac{1}{5} + 0.08} \right\} - 15 \\ &= 30 \left\{ 1 + 1.4 \log_e \frac{1.08}{0.28} \right\} - 15 \\ &= 30 \{ 1 + 1.4 \log_e 3.857 \} - 15 \\ &= 30(1 + 1.4 \times 2.303 \times 0.5863) - 15 \\ &= 20 \times 2.89 - 15 = 57.8 - 15 = 42.8 \text{ lbs. per square inch} \end{aligned}$$

Let A = area of cylinder required

$$\text{then } 600 \times 42.8 \times \frac{\pi}{10} \times A = 100 \times 33,000$$

$$\therefore A = \frac{100 \times 33,000}{54 \times 42.8 \times 10} = 142.7 \text{ square inches}$$

$$\therefore \text{diameter} = \sqrt{\frac{142.7}{0.7854}} = 13.27 \text{ say } 13\frac{1}{4} \text{ inches}$$

63. Binary Vapour Engine.—In this engine, invented by Du Tremblay about 1850, a combination of steam and a more volatile liquid (ether) was used as the working fluid. The heat in the exhaust steam from the steam-engine cylinder was utilised in evaporating ether, which in its turn did work in a separate cylinder. After being exhausted from the ether cylinder the ether was condensed in a surface condenser and the cycle repeated. By this means it was possible to have a net gain in efficiency, since more work was done per pound of steam than would have been possible in a steam-engine cylinder alone.

It has already been mentioned in Art. 53 that it does not pay to expand below a certain pressure on account of the frictional resistance, etc., but at the low temperature of the exhaust steam, ether vapour exerts a considerable pressure and enables the ether cylinder to be utilised with advantage. In order to get the best results with the binary engine it was found necessary to have a fairly high back pressure (about 7 pounds per square inch) in the steam cylinder, the result being that although the binary engine was more economical than the steam engine alone when working with this back pressure, yet in a modern well-designed steam engine with a low back pressure of about 2 pounds per square inch absolute, the gain would be a negligibly small quantity. In other words, an inefficient steam engine may, by the addition of an ether (or other volatile liquid) cylinder, be converted into an economical binary engine, but a binary engine will have a very little higher efficiency than the simpler modern steam engine.

The thermodynamic principles of the binary vapour engine will be best illustrated by means of the following example.

EXAMPLE.—In a binary vapour engine using SO_2 as the more volatile liquid the initial temperature of the steam = 327°F ., exhaust temperature = 100°F . The initial temperature of the SO_2 = 95°F ., exhaust temperature = 60°F . Given that the specific heat of liquid SO_2 = 0.4, and the latent heat of SO_2 = $176 - 0.27(t - 32)$ find—

(a) The efficiency of the steam engine alone.

(b) The weight of SO_2 used in the vapour cylinder per pound of steam in the steam cylinder.

(c) The combined efficiency of the two cylinders.

Assume both cylinders to work on the Rankine cycle, and that both steam and SO_2 are dry at admission into their respective cylinders. [L.U.]

$$L_1 = 1114 - 0.7 \times 327 = 1114 - 229 = 885 \text{ B.Th.U.}$$

(a) By (3), Art. 57.

$$\begin{aligned} \text{Efficiency of steam engine alone} &= \frac{(787 - 560)(1 + \frac{885}{787}) - 560 \log_e \frac{787}{560}}{885 + 787 - 560} \\ &= \frac{227 \times 2.124 - 190.58}{1112} = \frac{292}{1112} \\ &= 0.262 \text{ or } 26.2 \text{ per cent.} \end{aligned}$$

(b) We first require the dryness fraction of the exhaust steam, or we may get $x_2 L_2$ directly

$$\begin{aligned} x_2 L_2 &= T_2 \left(\frac{L_1}{T_1} + \log_e \frac{T_1}{T_2} \right) \text{ (Art. 46)} \\ &= 560 \left(\frac{885}{787} + \log_e \frac{787}{560} \right) \\ &= 560 (1.124 + 0.340) = 560 \times 1.464 \\ &= 820 \text{ B.Th.U.} \end{aligned}$$

Note.—This may also be found as follows. Since the expansion is adiabatic $x_2 L_2 = \text{net heat supplied} - \text{work done}$

$$= 1112 - 292 = 820 \text{ B.Th.U. as before.}$$

Heat available for evaporating SO_2 per pound of exhaust steam.

$$\begin{aligned} &= x_2 L_2 + h_{100} - h_{95} \\ &= 820 + 5 \\ &= 825 \text{ B.Th.U.} \end{aligned}$$

Heat of evaporation of SO_2 from 60°F. to 95°F.

$$\begin{aligned} &= 0.4(95 - 60) + 176 - 0.27(95 - 32) \\ &= 14 + 176 - 17 \\ &= 173 \text{ B.Th.U.} \end{aligned}$$

$$\therefore \text{weight of } \text{SO}_2 \text{ per pound of steam} = \frac{825}{173} = 4.767 \text{ pounds.}$$

(c) Work per pound of SO_2 by (7), Art. 57,

$$\begin{aligned} &= (95 - 60) \left(0.4 + \frac{159}{555} \right) - 0.4 \times 520 \log_e \frac{555}{520} \\ &= 35 \times 0.686 - 0.4 \times 520 \times 2.3026 \times 0.0283 \\ &= 24.01 - 13.55 \\ &= 10.46 \text{ B.Th.U.} \end{aligned}$$

$$\begin{aligned} \therefore \text{work for } 4.767 \text{ pounds of } \text{SO}_2 &= 10.46 \times 4.767 \\ &= 49.86 \text{ B.Th.U.} \end{aligned}$$

$$\begin{aligned} \text{and total work done for each pound of steam} &= 292 + 49.86 \\ &= 341.86 \text{ B.Th.U.} \end{aligned}$$

$$\begin{aligned} \text{Sensible heat per pound of exhaust } \text{SO}_2 &= 0.4(60 - 32) \\ &= 11.2 \text{ B.Th.U.} \end{aligned}$$

$$\begin{aligned} \text{Sensible heat of } 4.767 \text{ pounds} &= 11.2 \times 4.767 \\ &= 53.39 \text{ B.Th.U.} \end{aligned}$$

$$\therefore \text{nett heat supplied per pound of steam to the binary engine} \\ = 885 + (327 - 32) - 53.39 = 1126.6 \text{ B.Th.U.}$$

Hence the combined efficiency will be,

$$\frac{\text{Total work done}}{\text{Heat supplied}} = \frac{341.86}{1126.6} = 0.303 \text{ or } 30.3 \text{ per cent.}$$

EXAMPLES IV

1. Calculate the work done when 1 pound of steam expands adiabatically from 80 pounds per square inch absolute to 15 pounds per square inch absolute, (a) when the steam is originally dry saturated, and (b) when the dryness fraction is originally 0.9. Given, volume of 1 pound of dry steam at 80 pounds absolute = 5.47 cubic feet, and at 15 pounds absolute = 26.27 cubic feet. Use steam tables for any other data that may be required.

2. Steam 30 per cent. wet at 100 pounds per square inch absolute expands adiabatically to 20 pounds per square inch absolute. Find its wetness after expansion. If the expansion can be represented by $pv^n = \text{constant}$, find n .

3. A steam engine using saturated steam works non-expansively, the initial pressure being 120 pounds per square inch absolute, and the exhaust pressure 5 pounds per square inch absolute ($t = 162.3^\circ \text{ F.}$). Estimate the work done per pound of steam and the efficiency of the engine by calculation, and from a temperature-entropy chart, (a) when the steam is initially dry saturated, and (b) when the initial dryness fraction is 0.8. [Given, volume of 1 pound of dry saturated steam at 120 pounds absolute = 3.726 cubic feet, and temperature = 341° F.]

4. An engine using dry saturated steam works on the Rankine cycle between temperature limits of 350° F. and 140° F. Estimate the work done per pound of steam and the efficiency of the cycle.

5. Solve Problem 4 if the initial dryness fraction of the steam is 0.85.

6. A steam engine requires 300 B.Th.U. per minute per horse-power when working between temperature limits of 390 F. and 110 F. What is the ratio of its thermal efficiency to that of an ideal engine working between the same temperature limits (a) on the Rankine cycle, (b) on the Carnot cycle?

7. Estimate the pounds of steam required per hour per horse-power by an engine working on the Rankine cycle between temperatures of 330° F. and 210° F.

8. Superheated steam at 180 pounds per square inch absolute ($t = 373^\circ \text{ F.}$), and temperature 520° F. , expands adiabatically down to a pressure of 6 pounds per square inch absolute ($t = 170^\circ \text{ F.}$). Assuming that the Rankine cycle is followed by this steam, determine the weight of steam required per hour per horse-power, and the dryness of the steam after expansion ($C_p = 0.5$).

9. An engine is supplied with superheated steam at 120 pounds per square inch absolute ($t = 341^\circ \text{ F.}$) and exhausts at 4 pounds absolute ($t = 153^\circ \text{ F.}$). Taking the mean specific heat of the steam as 0.5, find the superheat which must be given to the steam at the higher pressure in order that after adiabatic expansion to the lower pressure it may be just dry and saturated. An engine works on the Rankine cycle with that degree of superheat and between the above pressures. Find its thermal efficiency and the work done per pound of steam.

10. In a Stirling engine fitted with a perfect regenerator, the maximum pressure is 135 pounds per square inch absolute and the minimum 15 pounds per square inch absolute, the upper and lower temperatures being 600° F. and 80° F. A perfectly reversible steam engine uses dry saturated steam between the same limits of pressure: compare their efficiencies. If the piston speed and stroke be the same in each engine, compare the diameters of the cylinders for equal power. [Given, temperature of steam at 135 pounds absolute = 350° F. , and at 15 pounds absolute = 213° F. , and specific volume at 15 pounds absolute = 26.27 cubic feet.]

11. An engine is fitted with steam jackets so that the steam remains dry and saturated throughout the expansion. If the initial temperature is 400° F. and the final back-pressure temperature is 110° F. , calculate the heat supplied by the jackets per pound of working steam and the efficiency of the engine.

12. Estimate the weight of steam required per hour per horse-power by an engine working between temperature limits of 200° C. and 60° C. , (a) on the Rankine cycle,

(b) when by the use of steam jackets the steam remains dry and saturated throughout the expansion.

13. In a compound steam engine the admission pressure to the high-pressure cylinder is 170 pounds per square inch absolute ($L = 855$ B.Th.U. and $t = 368.5^\circ$ F.), and the exhaust pressure in the low-pressure cylinder is 2 pounds absolute ($t = 126^\circ$ F.). The back pressure of the high-pressure cylinder and the admission pressure to the low-pressure cylinder is 50 pounds absolute ($t = 281^\circ$ F.). The feed water is heated in two stages; in the first stage, steam for feed heating is taken from the low-pressure steam chest, and in the second stage boiler steam is used. Assuming complete adiabatic expansion and no heat at losses, estimate the efficiency of the engine, and the gain due to feed heating.

14. If in Problem 13 the temperature of the feed water leaving the feed heater was 200° F., feed heating being obtained by the first stage only, estimate the efficiency of the engine.

15. In a regenerative triple-expansion engine the initial steam pressure is 220 pounds absolute ($L = 836$ B.Th.U., $t = 390^\circ$ F.) and the exhaust pressure in the low-pressure cylinder 2 pounds absolute ($t = 126^\circ$ F.). The pressure in the intermediate steam chest is 100 pounds absolute ($t = 328^\circ$ F.), and in the low-pressure steam chest 24 pounds absolute ($t = 238^\circ$ F.). Assuming complete adiabatic expansion and no heat losses, estimate the efficiency of the engine, (a) when the feed is heated in two stages, and (b) when steam for feed heating is taken from the low-pressure steam chest only.

16. The main engines of a vessel are supplied with steam at 200 pounds absolute ($t = 382^\circ$ F.) and use 17 pounds of steam per I.H.P. per hour, the temperature of the condenser water being 120° F. An auxiliary engine supplied with steam from the same boiler and exhausting into the atmosphere uses 25 pounds of steam per I.H.P. per hour. The main engines develop 6000 I.H.P. and the auxiliary engine 120 I.H.P. Find the actual efficiency (a) of the main engines alone, (b) of the whole plant when the auxiliary engine discharges into the hot well of the main engines.

17. The diameter of a steam-engine cylinder is 10 inches and the stroke 1 foot. If the initial pressure is 100 pounds per square inch absolute and cut-off is at $\frac{1}{2}$ stroke, find the theoretical mean effective pressure, neglecting clearance, the back pressure being 4 pounds absolute.

If the clearance is 0.125 of the piston displacement find the probable I.H.P. if the engine runs at 250 revolutions per minute. [Assume a diagram factor of 0.85.]

18. Find the diameter of a steam-engine cylinder required to develop 80 I.H.P. with a piston speed of 650 feet per minute. The initial steam pressure is 120 pounds per square inch absolute, back pressure 2 pounds absolute, cut-off $\frac{1}{3}$ stroke, clearance volume 7 per cent. of the piston displacement. Assume a diagram factor of 0.9.

19. A double-acting, single-cylinder engine of cylinder diameter 14 inches, stroke 24 inches, runs at 120 revolutions per minute and develops 90 I.H.P. The initial steam pressure is 90 pounds per square inch absolute and the back pressure 18 pounds absolute. Taking a diagram factor of 0.8, find the ratio of expansion.

20. In a binary vapour engine using steam and SO_2 , the initial temperature of the steam is 360° F. and the exhaust temperature 120° F. The initial temperature of the $\text{SO}_2 = 110^\circ$ F., and exhaust temperature 65° F. Given that the specific heat of liquid $\text{SO}_2 = 0.4$ and the latent heat of $\text{SO}_2 = 176 - 0.27(t - 32)$ find, (a) efficiency of the steam cylinder alone; (b) the combined efficiency of the binary engine. Assume both cylinders to work on the Rankine cycle, and that both the steam and SO_2 are dry at admission into their respective cylinders.

CHAPTER V

THE STEAM ENGINE—(CONTINUED)

64. **The Actual Indicator Diagram.**—The theoretical diagram has already been discussed in Art. 61; we now proceed to investigate the closeness with which the actual diagram approximates to this ideal. Fig. 47 shows the theoretical diagram with incomplete expansion, while Fig. 48 shows a typical example of a good indicator diagram taken from a condensing engine whose various parts are properly designed and adjusted.

In Fig. 47, AB is the admission line, and BC the expansion line. At

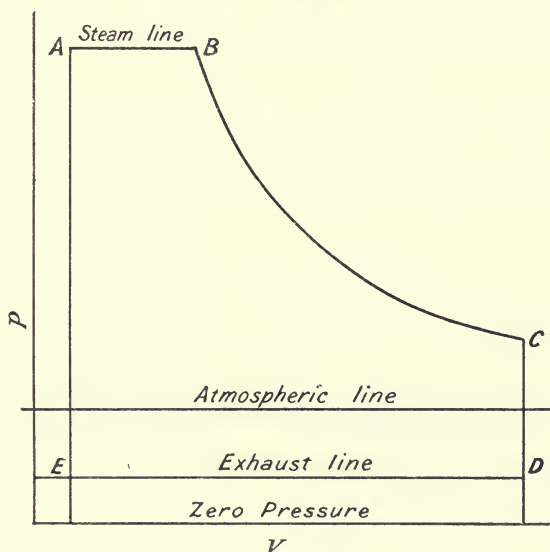

FIG. 47.—Theoretical diagram.

the end of the working stroke release takes place and the pressure falls, at constant volume, down to the exhaust pressure as represented by the line CD. During the exhaust stroke DE, the pressure remains constant, and on the completion of the stroke the exhaust valve is closed and steam admitted, the pressure rising at constant volume from E to A.

In the actual engine it is impossible to get a sharp corner at cut-off, because no valve will close instantaneously; the result is, the corner is rounded off as shown at *b*, Fig. 48. Similarly, at the end of the stroke

the diagram is rounded off as shown at *c*. Again, the exhaust valve is not kept open throughout the whole of the exhaust stroke, but is closed at some point such as *f*, and the stroke completed by compressing the steam up to some pressure such as indicated at *g*. This compression, or cushioning, is carried out for mechanical reasons, in order to bring the reciprocating parts of the engine to rest gradually, without shock, obtaining thereby sweeter running and longer life of the engine. The amount of compression required for this purpose depends upon the magnitude of the inertia forces to be absorbed, and in some high-speed engines the compression is carried on right up to the initial steam pressure at *a*. The

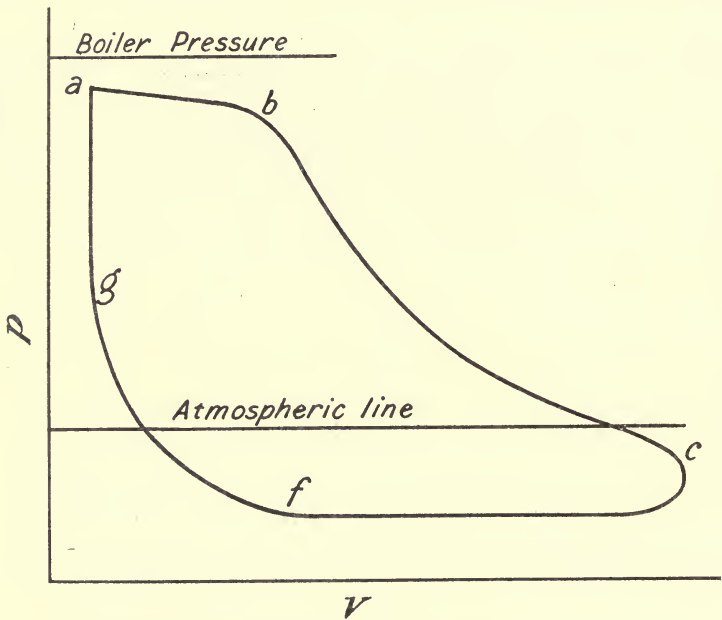

FIG. 48.—Typical indicator diagram from a condensing steam engine.

effect of rounding off these corners is to reduce the mean effective pressure as already mentioned in Art. 61, the amount of this reduction depending on the type of engine (see Art. 78).

65. Wire-drawing during Admission and Exhaust.—The pressure in the cylinder during admission (*ab*, Fig. 48) must always be less than the boiler pressure, because a certain difference of pressure is necessary to ensure a ready flow of steam from the boiler to the engine. In the case of high-speed engines with long steam pipes this difference is often very appreciable, but in no case should it exceed about 10 per cent. of the boiler pressure. The admission pressure also generally falls as the piston moves forward with increasing velocity, the admission line (*ab*, Fig. 48) sloping downwards towards the point of cut-off. This fall of pressure, or wire-drawing, during admission is due to the steam ports being of insufficient area to admit steam fast enough to maintain the full

pressure. With high-speed engines this defect is more marked than with slow speeds, and is always noticeable when the engine is developing its full power. Provided the wire-drawing is not excessive it can hardly be considered a defect, because with high-speed engines the area of the steam ports would have to be excessively large in order to produce a horizontal admission line.

Further wire-drawing will always take place past the steam valve as it closes at cut off, giving a rounded corner as already mentioned in Art. 61. The amount of wire-drawing at cut-off will depend upon the type of valve, being greatest with the ordinary slide valve, and least with that type of valve which closes the quickest.

The apparent loss due to wire-drawing during admission is represented by the shaded area in Fig. 49.

The actual loss, however, is

less than this amount because the effect of wire-drawing is to dry the steam (Art. 38), a portion of this apparently lost work re-appearing as heat in the steam.

Again, during exhaust there must be a difference of pressure between the actual back pressure in the cylinder and the pressure in the condenser, in order that the steam may flow from the cylinder into the condenser. The magnitude of this difference will depend to a certain extent upon the area of the exhaust passages from the cylinder to the condenser; in good practice it will amount to from 2 to 3 pounds per square inch.

In the non-condensing engine the back pressure in the cylinder will, for the same reason, be about the same amount above atmospheric pressure.

On account of the more or less gradual opening of the exhaust the steam is released at *c* (Fig. 48) before the end of the working stroke, in order that the pressure may be as

near as possible the same as the cylinder back pressure when the piston commences its exhaust stroke. This early release and gradual opening to exhaust causes the toe of the diagram to be rounded off as shown in Fig. 50.

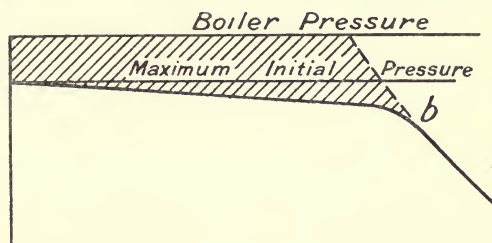

FIG. 49.—Apparent loss due to wire-drawing during admission.

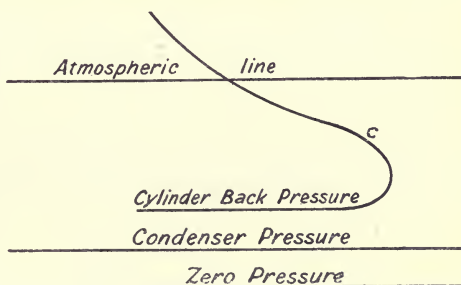

FIG. 50.—Effect of early release.

66. Clearance and Cushioning.—In the theoretical diagram with clearance, shown in Fig. 47, there is no compression of the steam, hence at the end of the exhaust stroke the clearance volume is filled with steam at the low back pressure during exhaust. During the commencement of the next working stroke, sufficient steam will have to be admitted to fill

this clearance space before any work is done on the engine piston, such steam being wasted. If it were not for the fact that the extra clearance steam present in the cylinder during expansion causes a higher mean pressure (Art. 62) than would be obtained with no clearance, the only effect of clearance would be to increase the steam consumption of the engine; actually, the effect of clearance is to raise the mean effective pressure (and therefore increase the work done in the cylinder) but at the same time increases the steam consumption to such an extent that the efficiency is reduced.

By compressing the steam up to some point g , Fig. 48, the waste due to clearance is reduced, since, at the commencement of the next working stroke, the clearance volume is full of steam at the higher pressure at g , and consequently less steam will be required to bring the pressure up to the admission pressure at a before work is done on the piston. If the compression is so great as to raise the pressure in the clearance space, just before admission, to the initial pressure of the steam, the loss due to clearance will be practically *nil*, because no steam will be required to fill the clearance space, and all the steam admitted up to cut-off will be available for doing work on the engine piston. In this case, however, the mean effective pressure on the piston will be greatly reduced, and if this degree of compression be allowed on full load, it will necessitate larger cylinders for a given speed of engine.

On account of the more or less gradual opening of the valve to steam, it is usual to open the valve just before the end of the exhaust stroke; this is known as *pre-admission*, and the valve is said to have a *lead*. In addition to ensuring full pressure of steam on the piston at the commencement of the working stroke, pre-admission helps cushioning and therefore assists in absorbing the inertia forces when bringing the reciprocating parts to rest.

67. Initial Condensation and Re-evaporation during Expansion and Exhaust.—When steam is admitted into an engine cylinder it mixes with the contents of the clearance space, and comes into contact with the cylinder walls; since in almost all engines the temperature of the cylinder walls is below that of the entering steam it follows that some of the steam is condensed. This initial condensation continues up to the point of cut-off, and its amount will depend upon the temperature difference between the steam admitted and the cylinder walls, the nature of the clearance surface, *i.e.* whether dry or wet, and the clearance volume.

The larger the clearance volume the greater will be the clearance surface, and the greater the initial condensation, hence for this reason alone it is desirable to keep down the clearance volume to as low a figure as practicable. With a given clearance, the amount of initial condensation will depend upon the rate of condensation rendered possible by the condition of the clearance surface. The time during which the steam is in contact with the cylinder walls, the temperature and amount of moisture on the walls are all factors which determine how much steam will be condensed.

After cut-off has been reached more steam is condensed as the result of expansion, but a point is soon reached at which the fall of pressure (and therefore of the temperature of saturation of the steam) results in some of the water being re-evaporated, such re-evaporation during expansion being

continued up to the point of release. When the valve opens to exhaust, the pressure is still further reduced and the rate of re-evaporation increased, and during the exhaust stroke it is continued until, when compression commences, the steam is more or less just dry and saturated.

From the above it will be seen that during admission the cylinder walls extract heat from the steam, and by so doing raise their own temperature and produce initial condensation. During expansion and exhaust, some of the heat thus stored in the cylinder walls is given back to the steam, producing thereby re-evaporation and a consequent fall in temperature of the walls.

The amount of condensation also depends upon the *mean* temperature of the cylinder walls, and for the same *range* of temperature will increase as the *mean* temperature decreases.

68. Temperature Range of Cylinder Walls.—If heat is being steadily transmitted through a metal plate of conductivity K and thickness x , whose temperature on one side is T_1 and on the other side T_2 , then it

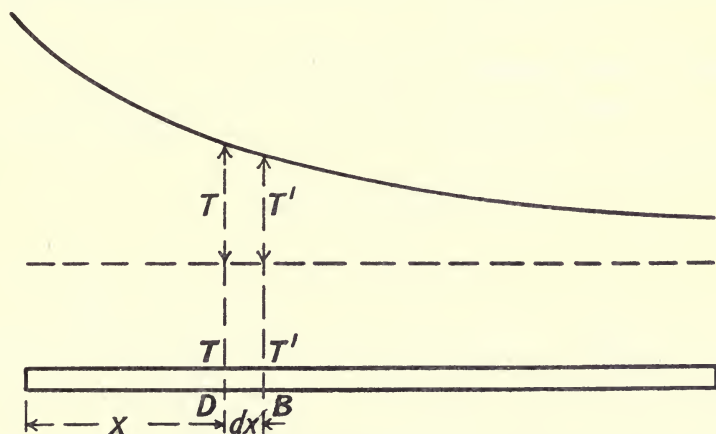

FIG. 51.

is known that the quantity of heat transmitted per second through unit area of the plate is

$$Q = K \cdot \frac{T_1 - T_2}{x}$$

If, however, the flow of heat is not steady the heat transmitted across any unit section will be

$$Q = -K \frac{dT}{dx}$$

where $\frac{dT}{dx}$ is the temperature gradient at that section.

Consider the flow of heat along a bar of uniform cross-section A . Let T be the temperature at a point D distance x from one end, and T' the temperature at a point B , $x + \delta x$ from that end (Fig. 51), then

$$T' = T + \frac{dT}{dx} \cdot \delta x$$

where $\frac{dT}{dx}$ is the mean temperature gradient between the two points.

The flow of heat across the section at B per second will be

$$\begin{aligned}
 & -KA \frac{d}{dx} \left(T + \frac{dT}{dx} \cdot \delta x \right) \\
 & = -KA \left(\frac{dT}{dx} + \frac{d^2T}{dx^2} \cdot \delta x \right)
 \end{aligned}$$

If the flow of heat has attained a steady condition, the difference between the amounts of heat flowing across the sections D and B must be lost in radiation, hence

Heat lost in radiation per second from D to B

$$\begin{aligned}
 & = -KA \frac{dT}{dx} \cdot \delta x - \left\{ -KA \left(\frac{dT}{dx} + \frac{d^2T}{dx^2} \cdot \delta x \right) \right\} \\
 & = KA \frac{d^2T}{dx^2} \cdot \delta x \quad \dots \dots \dots (1)
 \end{aligned}$$

Let e = surface emissivity of the bar, and p its perimeter, then

$$\text{Heat radiated per second from C to B} = e p T \delta x \quad \dots (2)$$

Equating (1) and (2) gives

$$\begin{aligned}
 & KA \frac{d^2T}{dx^2} \delta x = e p T \delta x \\
 & \text{or } KA \frac{d^2T}{dx^2} = e p T \quad \dots \dots \dots (3)
 \end{aligned}$$

Next consider the flow of heat before a steady state has been attained. During this stage the difference between the heat flowing into and that flowing out of the layer DB of thickness δx is expended in raising the temperature of the layer in addition to that lost in radiation.

Let C be the thermal capacity per unit of volume of the material of the bar, and let the mean temperature of the layer DB increase by the amount δT in time δt , then

$$\begin{aligned}
 & \text{Heat expended per second in raising the temperature of the layer} \\
 & = C \cdot A \cdot \delta x \cdot \frac{dT}{dt}
 \end{aligned}$$

and equation (3) becomes

$$K \cdot A \cdot \frac{d^2T}{dx^2} = e p T + C \cdot A \cdot \frac{dT}{dt} \quad \dots \dots \dots (4)$$

If now the bar be assumed covered with a perfect non-conductor of heat, or what amounts to the same thing, consider the heat to be flowing through a plate of infinite area, in which case $e = 0$, equation (4) becomes

$$\begin{aligned}
 & K \cdot A \cdot \frac{d^2T}{dx^2} = 0 + C \cdot A \cdot \frac{dT}{dt} \\
 & \text{or } \frac{K}{C} \cdot \frac{d^2T}{dx^2} = \frac{dT}{dt}
 \end{aligned}$$

which may be written

$$k \frac{d^2T}{dx^2} = \frac{dT}{dt} \dots \dots \dots (5)$$

where $k = \frac{K}{C}$ the diffusivity of the material.

Equation (5) gives the connection between the temperature at different points in the thickness of the metal and the rate of change of temperature.

Assuming a periodic change in temperature of the inside skin of the cylinder walls, the temperature changes at a point in the thickness of the walls will, after a time, attain a fixed character, and the mean temperature will remain steady. Let N be the uniform speed of the crank in revolutions per minute; T the surface temperature of the walls at any instant; T_1 the maximum temperature and $-T_1$ the minimum temperature, *i.e.* the temperature range of the inside skin of the cylinder walls varies from T_1 above to T_1 below the *mean* temperature.

$$\begin{aligned} \text{Then} \quad T &= T_1 \cos \theta \\ &= T_1 \cos 2\pi Nt \dots \dots \dots (6) \end{aligned}$$

where θ is the angle turned through by the crank in t minutes.

From (5) and (6)

$$\begin{aligned} k \cdot \frac{d^2T}{dx^2} &= \frac{dT}{dt} = \frac{d}{dt} \cdot (T_1 \cos 2\pi Nt) \\ \therefore k \cdot \frac{d^2T}{dx^2} &= \frac{dT}{d\theta} \cdot 2\pi N \\ \frac{d^2T}{dx^2} - \frac{2\pi N}{k} \cdot \frac{dT}{d\theta} &= 0 \end{aligned}$$

$$\text{Let} \quad \sqrt{\frac{N\pi}{k}} = \mu$$

$$\text{Then} \quad \frac{d^2T}{dx^2} - 2\mu^2 \frac{dT}{d\theta} = 0 \dots \dots \dots (7)$$

$$\text{The solution of this equation is } T = T_1 e^{-\mu x} \cos(\theta - \mu x) \dots (8)$$

Now the surface temperature at any instant is $T = T_1 \cos \theta$, hence from (8), which gives the temperature at any point within the metal at any time, we see that at any point distant x from the inside skin of the walls, the temperature range is reduced from T_1 to $T_1 e^{-\mu x}$, and that the actual temperature lags behind the surface temperature by the angle μx . Hence, when the temperature waves lag behind by a complete period, *i.e.* when $\mu x = 2\pi$, they agree in phase with those at the surface. To find the depth at which this occurs we have:—

$$\begin{aligned} \mu x = 2\pi \text{ or } x &= \frac{2\pi}{\mu} = \sqrt{\frac{N\pi}{k}} \\ \therefore x &= \sqrt{\frac{4\pi^2 k}{N\pi}} = \sqrt{\frac{4\pi k}{N}} \dots \dots \dots (9) \end{aligned}$$

Substituting for k the values obtained by Messrs. Callendar and Nicolson,¹

$$K = 5.4 \text{ and } C = 4.5 \quad \therefore k = 1.20$$

$$x = \sqrt{\frac{4 \times 3.1416 \times 1.2}{N}} = \sqrt{\frac{15.1}{N}} \dots (10)$$

The variation in temperature above or below the mean temperature at this point is $T = T_1 e^{-\mu x} \cos \theta$ from (8), and the maximum value of $T = T_1 e^{-\mu \pi} = T_1 e^{-2\pi}$.

Substituting for $e = 2.7182$, this becomes—

Maximum value of T at the depth where the temperature waves are in step with those at the surface is

$$T = \frac{T_1}{(2.7182)^{2\pi}} = \frac{T_1}{527}$$

If we assume a speed of, say, 100 revolutions per minute

$$x = \sqrt{\frac{15.1}{100}} = 0.388 \text{ inch}$$

and a thermometer placed in the metal wall at this depth would give practically a steady reading.

Rate of Flow of Heat.—Now $Q = -K \cdot \frac{dT}{dx}$. In order to find

Q at any instant we must find $\frac{dT}{dx}$ at the surface.

From (8) $T = T_1 e^{-\mu x} \cos(\theta - \mu x)$

$$\therefore \frac{dT}{dx} = -\mu T_1 e^{-\mu x} \cos(\theta - \mu x) + \mu T_1 e^{-\mu x} \sin(\theta - \mu x)$$

putting $x = 0$, at the surface

$$\frac{dT}{dx} = \mu T_1 (\sin \theta - \cos \theta)$$

$$\therefore Q = K \mu T_1 (\cos \theta - \sin \theta) \dots (11)$$

Now Q has its maximum positive value when $(\cos \theta - \sin \theta)$ is a maximum.

i.e. when $\frac{d}{d\theta} (\cos \theta - \sin \theta) = 0$

$$-\sin \theta - \cos \theta = 0$$

$$\text{or when } \cos \theta = -\sin \theta$$

This happens when $\theta = -\frac{\pi}{4}$

We next want the values of θ between which heat is flowing into the metal. From (11) $Q = 0$ when $\cos \theta = \sin \theta$, *i.e.* when $\theta = \frac{\pi}{4}$ or $-\frac{3\pi}{4}$

and since Q is a maximum when $\theta = -\frac{\pi}{4}$, it follows that heat must be flowing into the metal whilst θ changes from $-\frac{3\pi}{4}$ to $\frac{\pi}{4}$.

¹ Proc. Inst. C. E., vol. cxxxi. 1898.

Now heat flow per minute $Q = K\mu T_1(\cos \theta - \sin \theta)$ ((11) above)

$$\therefore \text{heat flow per unit angle} = \frac{Q}{2\pi N} = \frac{K}{2\pi N} \cdot \mu T_1 (\cos \theta - \sin \theta)$$

and the heat flowing in per revolution is

$$\begin{aligned} & \int_{-\frac{3\pi}{4}}^{\frac{\pi}{4}} \frac{K}{2\pi N} \cdot \mu T_1 (\cos \theta - \sin \theta) d\theta \\ &= \frac{K\mu T_1}{2\pi N} \int_{-\frac{3\pi}{4}}^{\frac{\pi}{4}} (\cos \theta - \sin \theta) d\theta \\ &= \frac{K\mu T_1}{2\pi N} \left[[\sin \theta]_{-\frac{3\pi}{4}}^{\frac{\pi}{4}} + [\cos \theta]_{-\frac{3\pi}{4}}^{\frac{\pi}{4}} \right] \\ &= \frac{K\mu T_1}{2\pi N} \left[\left(\frac{1}{\sqrt{2}} + \frac{1}{\sqrt{2}} \right) + \left(\frac{1}{\sqrt{2}} + \frac{1}{\sqrt{2}} \right) \right] \\ &= \frac{\sqrt{2} K\mu T_1}{\pi N} \end{aligned}$$

But $\mu = \sqrt{\frac{N\pi}{k}}$ and $K = 5.4$, $k = 1.2$

$$\begin{aligned} \therefore \text{heat flowing in per revolution} &= \frac{K}{\sqrt{k}} \sqrt{\frac{2}{\pi N}} \cdot T_1 \\ &= \frac{5.4 T_1}{\sqrt{1.2}} \sqrt{\frac{2}{3.14 N}} \\ &= \frac{4 T_1}{\sqrt{N}} \text{ B.Th.U. (12)} \end{aligned}$$

From (12) we see that the heat absorbed by the cylinder walls per square foot of surface per revolution of the crank is $\frac{4T_1}{N}$, where T_1 is half the actual temperature range of the metal surface and N the revolutions made by the crank per minute.

The temperature of the cylinder walls does not necessarily follow that of the steam, as may be shown from the following example taken from Professor A. L. Mellanby's paper on the "Effects of Steam-Jacketing upon the Efficiency of a Horizontal Compound Steam-Engine."¹

In one trial (No. 95) the temperature range of the steam was from 357° F. to 247° F., *i.e.* 110° F. or T_1 above = 55° F. The speed of the engine was 60 revolutions per minute, and the surface available for condensation at each end of the cylinder was 6 square feet, hence from (12)—

$$\begin{aligned} \text{Heat absorbed per square foot per revolution} &= \frac{4T_1}{\sqrt{N}} \text{ B.Th.U.} \\ &= \frac{4 \times 55}{\sqrt{60}} \text{ B.Th.U.} \end{aligned}$$

$$\begin{aligned} \text{and heat absorbed at each end per minute} &= \frac{4 \times 55}{\sqrt{60}} \times 60 \times 6 \\ &= 10,200 \text{ B.Th.U.} \end{aligned}$$

¹ *Proc. Inst. Mech. Engrs.*, 1905, p. 544.

Taking the latent heat of steam at 357° F. as 860 B.Th.U. per pound, the steam which would be condensed per minute $= \frac{10,200}{860} = 11.9$ pounds at each end.

Hence the steam condensed per hour at
 both ends if the walls followed the
 same temperature variation as the
 steam $\left. \vphantom{\begin{matrix} \text{Hence the steam condensed per hour at} \\ \text{both ends if the walls followed the} \\ \text{same temperature variation as the} \\ \text{steam} \end{matrix}} \right\} = 11.9 \times 60 \times 2 = 1428$ pounds

In the actual trial the missing quantity (Art. 71) at cut-off was only 753 pounds per hour, so that it is evident that in this case the cylinder walls did *not* have so great a range of temperature as the steam. If we assume that all this missing quantity (753 pounds per hour) was due to initial condensation, it follows that the maximum temperature range of the cylinder walls was

$$110 \times \frac{753}{1428} = 58^{\circ} \text{ F.}$$

whereas the temperature range of the steam was 110° F.

It has been shown above that if the temperature range of the surface is known, the range at any depth within the metal can be found (eq. 8). Conversely, if the range at any depth within the metal can be measured, then, assuming a simple harmonic temperature-range at the surface, the surface range and also the heat absorbed per cycle can be easily calculated. Messrs. Callender and Nicolson¹ found by experiment that the surface temperature, instead of following that of the steam, went only through a very small range. In one particular case, at 70 revolutions per minute, the temperature of the steam varied from 335° F. to 212° F., a range of 123° F., but the temperature range of the inside surface of the cylinder walls was only 7° F.

69. Indicated Weight of Steam.—In order to estimate the steam consumption of an engine from the indicator diagram it is assumed that the steam in the cylinder is dry and saturated. Thus, in Fig. 52 AB represents the stroke volume and OA is made equal to the clearance volume to the same scale. Then at any point *c* after cut-off, the volume of steam in the cylinder as shown by the indicator diagram, *i.e.* the indicated volume, is represented by the length OC, equal to, say, *v* cubic feet. The absolute pressure of the steam at this point (*p*) is represented to scale by the length *cC*. From steam tables the volume of one pound of dry saturated steam at absolute pressure *p* is obtained; suppose this is *V* cubic feet, then assuming dry steam at point *c* it is evident that the weight of steam present in the cylinder is

$$\frac{\text{indicated volume (cubic feet)}}{\text{volume per pound cubic feet}} \text{ pounds} = \frac{OC}{V} \text{ or } \frac{v}{V} \text{ pounds}$$

70. Saturation Curve applied to an Indicator Diagram—Dryness of Steam.—This curve represents the ideal expansion curve to be obtained in a steam-engine cylinder, being the curve that would be obtained if the whole contents of the cylinder were present throughout the stroke as dry saturated steam. In Fig. 53 OA represents the clearance

¹ *Proc. Inst. C. E.*, vol. cxxi, 1898.

volume to the same scale that AB represents the stroke volume. The

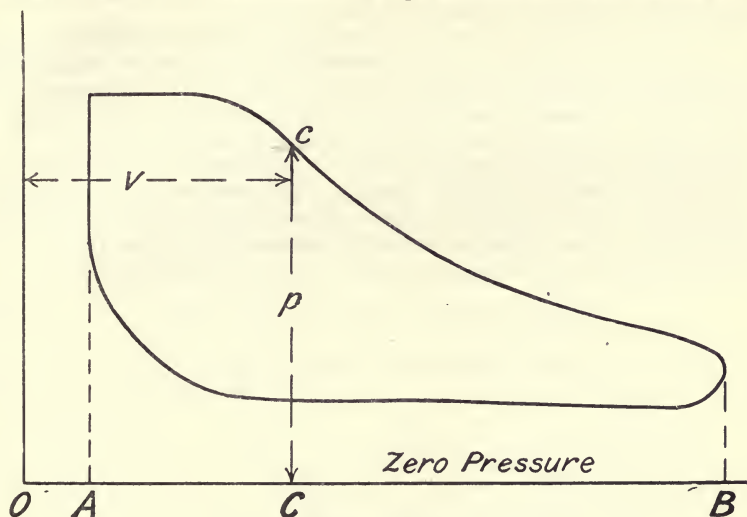

FIG. 52.—Indicated weight of steam.

total steam present in the cylinder during expansion is made up of two

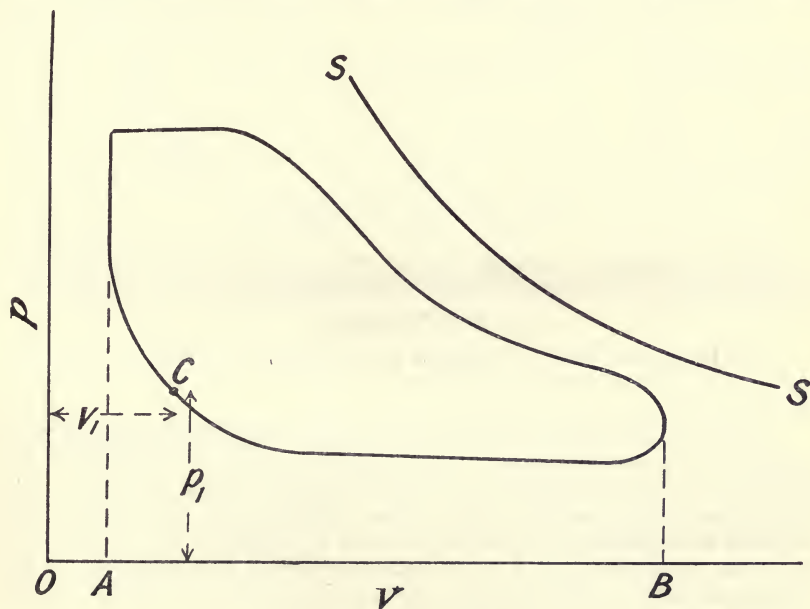

FIG. 53.—Saturation curve.

parts, namely, the weight of steam passing through the engine per stroke

called the *cylinder feed*, and the weight of steam contained in the clearance space before admission, called the *cushion steam*.

The cylinder feed is determined experimentally by running the engine for, say, one hour, condensing and then weighing the exhaust steam; from the measured steam consumption and the number of strokes made, the cylinder feed in pounds per stroke is easily calculated. The weight of cushion steam is found from the indicator diagram as follows:—

Any convenient point such as C, Fig. 53, is selected on the compression curve and the pressure p_1 pounds per square inch absolute, and the indicated volume v_1 cubic feet measured. Let V_1 denote the volume in cubic feet of one pound of dry saturated steam at pressure p_1 , obtained from steam tables, then, assuming the cushion steam to be dry and saturated,

$$\text{weight of cushion steam } w = \frac{v_1}{V_1} \text{ pounds}$$

Let W = measured cylinder feed in pounds per stroke.

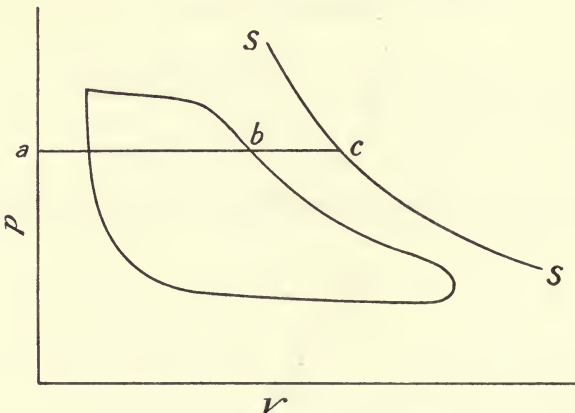

FIG. 54.—Dryness fraction of steam.

Then, assuming no leakage past the valve or piston, the total weight of steam present in the cylinder during expansion will be

$$w + W \text{ pounds}$$

The saturation curve is obtained by plotting on the indicator diagram with the help of steam tables, a curve for $w + W$ pounds of steam as shown by SS in Fig. 53.

Dryness Fraction of the Steam from an Indicator Diagram.—

Having drawn the saturation curve as explained above, the dryness of the steam at any point during the expansion may be found as follows. At any point b (Fig. 54) the actual volume occupied by the steam in the cylinder is represented by the length ab ; the volume which would be occupied by the steam if it were dry and saturated is represented by the length ac , hence, neglecting the volume of the water contained in the cylinder steam its dryness fraction will be represented by

$$\frac{ab}{ac}$$

The dryness fraction may also be expressed as

$$\frac{\text{indicated weight}}{\text{total weight present in the cylinder}} = \frac{\text{indicated volume (} ab \text{ cubic feet)} \times \text{density (in pounds per cubic foot)}}{\text{weight of cushion steam (} w \text{ pounds)} + \text{weight of cylinder feed (} W \text{ pounds)}}$$

71. Missing Quantity.—It will usually be found in practice that the indicated weight of steam after cut-off is less than the measured steam consumption; the difference is known as the missing quantity and is represented on the indicator diagram by the length bc (Fig. 54). Owing to

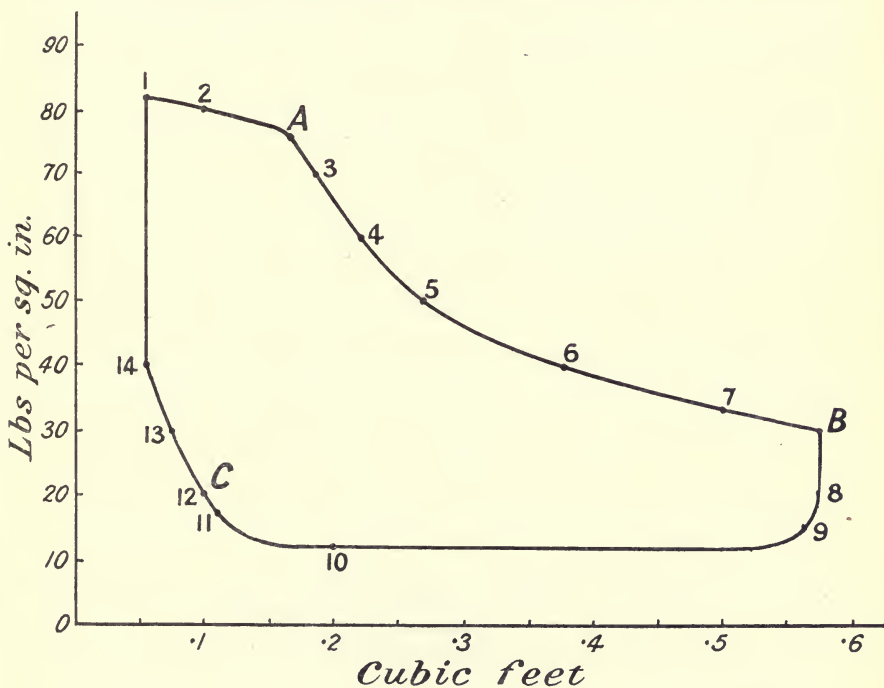

FIG. 55.

re-evaporation during expansion the missing quantity is almost always less at release than at cut-off.

EXAMPLE 1.—A calibrated indicator diagram is shown in Fig. 55. The measured steam consumption was 1344 pounds per hour at a speed of 200 revolutions per minute. The engine is double-acting and the card shown is an average diagram from both sides of the piston. Estimate the dryness fractions and missing quantities at cut-off and release, and deduce the interchange of heat per pound of steam between the steam and cylinder walls.

From the figure we see that at the point C on the compression curve when the pressure is 20 pounds per square inch absolute, the indicated

volume is 0.098 cubic foot. From steam tables the volume of 1 pound of dry saturated steam at this pressure is 20 cubic feet.

$$\text{Hence weight of cushion steam} = \frac{0.098}{20} = 0.0049 \text{ pound}$$

$$\text{Cylinder feed per stroke} = \frac{1344}{200 \times 2 \times 60} = 0.056 \text{ pound.}$$

$$\therefore \text{Total weight of steam present during expansion} = 0.0049 + 0.056 \\ = 0.0609 \text{ pound}$$

At cut-off (point A) the pressure is 76 pounds absolute, the indicated volume is 0.166 cubic foot, and the specific volume (from steam tables) 5.74 cubic feet per pound. If, therefore, the steam were dry and saturated its volume at cut-off would be

$$5.74 \times 0.0609 = 0.349 \text{ cubic foot}$$

$$\text{Hence dryness fraction at cut-off} = \frac{0.166}{0.349} = 0.475 \text{ or } 47.5 \text{ per cent.}$$

$$\text{Indicated weight at cut-off} = \frac{0.166}{5.74} = 0.0289 \text{ pound}$$

$$\therefore \text{missing quantity} = 0.0609 - 0.0289 \\ = 0.032 \text{ pound per stroke} \\ = 0.032 \times 2 \times 200 \times 60 \\ = 768 \text{ pounds per hour}$$

At release (point B) the pressure is 30 pounds absolute, the indicated volume 0.575 cubic feet, and the specific volume (from steam tables) 13.7 cubic feet per pound. The indicated weight at release will therefore be

$$\frac{0.575}{13.7} = 0.042 \text{ pound}$$

$$\text{Hence dryness fraction at release} = \frac{0.042}{0.0609} = 0.690 \text{ or } 69 \text{ per cent.}$$

$$\text{Missing quantity at release} = 0.0609 - 0.0420 \\ = 0.0189 \text{ pound per stroke} \\ = 0.0189 \times 2 \times 200 \times 60 \\ = 453 \text{ pounds per hour}$$

From the diagram the mean effective pressure during expansion from A to B is 36 pounds per square inch, hence the work done by 0.0609 lb. of steam is

$$\text{Mean pressure (lbs. per sq. ft.)} \times \text{change in volume (cub. ft.)} \\ = 36 \times 144 (0.575 - 0.166) \\ = 2128 \text{ foot-pounds}$$

$$\therefore \text{work done per pound of steam} = \frac{2128}{0.0609 \times 778} = 44.9 \text{ B.Th.U.}$$

At cut-off the pressure is 76 pounds absolute ($L = 903$, $t = 308^\circ \text{ F.}$).

$$\therefore \text{heat per pound at cut-off} = 308 - 32 + 0.475 \times 903 \\ = 276 + 429 \\ = 705 \text{ B.Th.U.}$$

At release the pressure is 30 pounds absolute ($L = 945$, $t = 250^\circ \text{ F.}$).

$$\begin{aligned} \therefore \text{heat per pound at cut-off} &= 250 - 32 + 0.690 \times 945 \\ &= 218 + 652 \\ &= 870 \text{ B.Th.U.} \end{aligned}$$

Let H_j = heat received per pound from the cylinder walls between cut-off and release, then assuming no heat losses

$$\begin{aligned} 705 + H_j &= 870 + 44.9 = 914.9 \\ \therefore H_j &= 914.9 - 705 \\ &= 209.9 \text{ B.Th.U.} \end{aligned}$$

EXAMPLE 2.—Dry steam is admitted to an engine cylinder at 84 pounds per square inch absolute ($t = 315^\circ \text{ F.}$, $L = 898 \text{ B.Th.U.}$, specific volume = 5.22 cub. ft.) and the condensation during admission is 25 per cent. of the whole steam supply. During expansion one-half of the heat absorbed by the cylinder walls during admission is returned to the steam at a uniform rate as the temperature falls. If the expansion be complete and the back pressure be 8 pounds per square inch absolute ($t = 183^\circ \text{ F.}$, $L = 988 \text{ B.Th.U.}$, $v = 47.3 \text{ cub. ft.}$), find the dryness fraction at the end of expansion. Also, assuming the exhaust steam homogeneous in quality, find its dryness fraction. Neglect clearance, heat losses due to radiation and conduction, and assume the specific heat of water to be constant and equal to unity.

From steam tables we find the following :—

Pressure.	Temperature, ° F.	Latent heat.	Specific volume.	Entropy.	
				Water.	Evaporation.
84	315	898	5.22	0.4579	1.1581
8	183	988	47.3	0.2673	1.5380

The temperature-entropy diagram is shown in Fig. 56. Since the condensation during admission is 25 per cent., it follows that the dryness fraction of the steam at cut-off is 0.75 or $\frac{BC}{BE}$. The dryness fraction at the end of expansion is represented by $\frac{AD}{AG}$.

The heat absorbed per pound of steam by the cylinder walls during admission is

$$\frac{898}{4} = 224.5 \text{ B.Th.U.}$$

the heat returned during expansion while the temperature falls 132° F.

$$= \frac{224.5}{2} = 112.25 \text{ B.Th.U.}$$

$$\therefore \text{rate of heat return} = \frac{112.25}{132}$$

$$= 0.85 \text{ B.Th.U. per } ^\circ \text{ F. fall in temperature}$$

$$\therefore \delta H = 0.85 \delta T$$

$$\text{or } \frac{\delta H}{T} = \delta \phi = 0.85 \frac{\delta T}{T}$$

absorbed heat to the steam namely 112.25 B.Th.U. Hence the further rise in entropy DK during exhaust will be

$$\frac{112.25}{643} = 0.1745 \text{ units}$$

and the dryness fraction at the end of exhaust will be

$$\begin{aligned} \frac{AK}{AG} &= \frac{1.2091 + 0.1745}{1.538} \\ &= 0.90 \text{ or } 90 \text{ per cent.} \end{aligned}$$

It should be noticed that the shaded area CDF represents the extra work done per pound of steam as the result of re-evaporation during expansion, and that the actual expansion line CD, which may also be called the re-evaporation line, shows at a glance how the expansion deviates from the adiabatic CF.

72. Method of Drawing the Temperature-Entropy from the Indicator Diagram.—The method will be best illustrated by means of an example. Consider the diagram shown in Fig. 55. The maximum steam pressure at admission is 82 pounds per square inch absolute ($t = 313^\circ \text{ F.}$) and the back pressure during exhaust is 12 pounds absolute ($t = 202^\circ \text{ F.}$). The first step consists in finding the dryness fraction of the steam at *any* point on the expansion curve. This has been found to be 0.690 for the point of release B in Example 1 worked out in Art. 71. The point B may therefore be transferred directly on to the temperature-entropy chart. On the indicator diagram at B (Fig. 55) it has already been shown that the cylinder contained 0.0609 pound of steam, of dryness 0.692, and occupying a volume of 0.575 cubic foot. The temperature-entropy diagram, however, is drawn for 1 pound of steam. The actual volume occupied by 1 pound of steam of dryness 0.692 and pressure 30 pounds absolute is, neglecting the volume of water,

$$13.6 \times 0.690 \text{ cubic feet}$$

The $T\phi$ diagram will, therefore, be drawn for an engine which is

$$\frac{13.6 \times 0.690}{0.575} = 16.36 \text{ times larger than the actual engine.}$$

If, now, any point on the indicator diagram be taken and the volume of the steam actually present in the cylinder be measured and then multiplied by 16.36, the corresponding point on the $T\phi$ diagram is completely determined.

A series of points 1, 2, 3, 4, etc., are next taken on the pv diagram at convenient pressures, and the pressure and volume read off for each point. Each volume is then multiplied by the factor 16.36 and the points plotted on the $T\phi$ diagram. The results obtained are shown in the following table.

It should be remembered that in the above method the effect of valve leakage is neglected, and it is assumed that the weight of steam present in the engine cylinder during expansion is a constant quantity. If the amount of leakage is known, an allowance should be made for it. For the method to be followed in such cases see the First Report of the Steam Engine Research Committee of the Institution of Mechanical Engineers.¹

¹ *Proc. I. Mech. E.*, 1905, p. 239.

Point.	Absolute pressure, lbs. per sq. in.	Volumes.	
		pv	$T\phi$.
I	82	0.055	0.90
2	80	0.100	1.64
A	76	0.166	2.71
3	70	0.184	3.01
4	60	0.221	3.61
5	50	0.268	4.38
6	40	0.374	6.12
7	33	0.500	8.18
B	30	0.575	9.40
8	20	0.575	9.40
9	15	0.566	9.27
10	12	0.200	3.27
11	17	0.110	1.80
12	20	0.100	1.64
13	30	0.074	1.21
14	40	0.055	0.90

The temperature-entropy diagram is most conveniently drawn by laying a piece of tracing paper over the $T\phi$ chart and plotting the points directly on it. Thus, the position on the chart corresponding to point 1 is the intersection of the constant-pressure line for 82 pounds per square inch, with the constant volume line for 0.90 cubic foot, and similarly for all the other points. The complete temperature-entropy diagram, corresponding to the indicator diagram shown in Fig. 55 is thus drawn, being shown in Fig. 57.

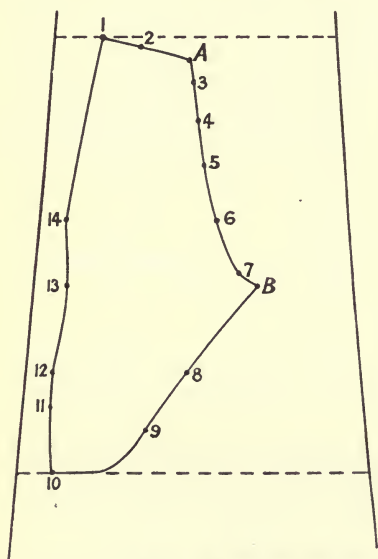

FIG. 57.— $T\phi$ diagram for pv diagram shown in Fig. 55.

When the temperature-entropy diagram is drawn in this, or any other way, the expansion line clearly shows the nature of the interchange of heat between the steam and the cylinder walls. Referring to Fig. 57 it will be seen that throughout the expansion from A to B there is a gain of entropy, and therefore the cylinder walls are restoring heat to the steam, and as re-evaporation continues, the dryness fraction of the steam increases as shown.

73. Boulvin's Method of drawing the Temperature-Entropy Diagram from the Indicator Diagram.—Draw the axes OP , OT , OV , and OE (Fig. 58). Set off along OV

a scale of volumes, in cubic feet for 1 pound of steam, making its length to represent at least the volume of 1 pound of steam at the lowest pressure on the indicator diagram. On OT set off a scale of temperature and along

OP a scale of pressure; then by the aid of steam tables plot the temperature-pressure curve for saturated steam as shown in the quadrant POT.

The indicator diagram is next to be transferred to the quadrant POV. Draw in this quadrant the saturation curve for 1 pound of steam, using steam tables. On the actual indicator diagram draw the saturation curve for the actual weight of steam present during expansion by the method already explained in Art. 70. Next transfer the actual indicator diagram

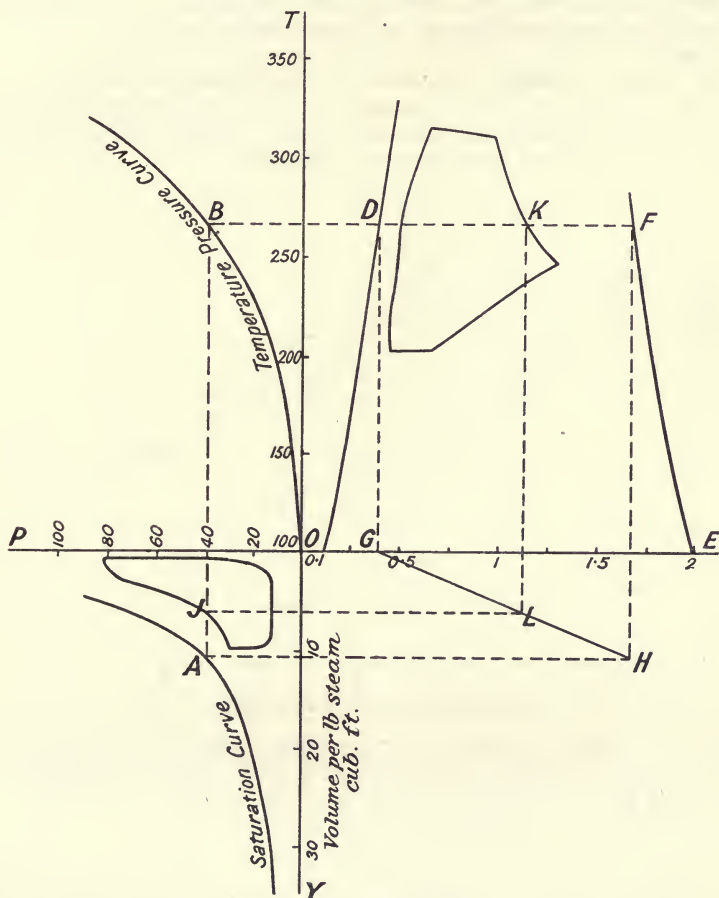

FIG. 58.—Boulvin's method.

(Fig. 59) to the quadrant POV with the same relationship to the saturation curve already drawn therein as it has to its own saturation curve, plotting it directly to the new scale of pressures and volume.

In the quadrant TOE draw the steam and water lines of the temperature-entropy diagram for 1 pound of steam by the method of Art. 42, or transfer these lines directly from a temperature-entropy chart.

Take any convenient point A on the saturation curve and draw the

vertical line AB to the temperature-pressure curve, and the horizontal BF cutting the entropy lines in D and F. Project DG vertically to cut OE in G, and FH to cut the horizontal from A in H. Join HG; from J draw a horizontal to cut HG in L, and from L draw a vertical to cut BC in K. Then K is a point on the $T\phi$ diagram required. Repeat this process for different points on the indicator diagram, and in this manner the indicator diagram is transferred to the temperature-entropy diagram. Fig. 59 shows the actual indicator diagram, already considered by the other method, with its saturation curve, and Fig. 58 is drawn from it by the above graphical method.

74. Valve Leakage.—In order to draw the saturation curve on an indicator diagram one of the assumptions made in Art. 70 was that the engine cylinder contained a constant weight of steam during expansion, namely, the sum of the cushion steam and cylinder feed. On this assump-

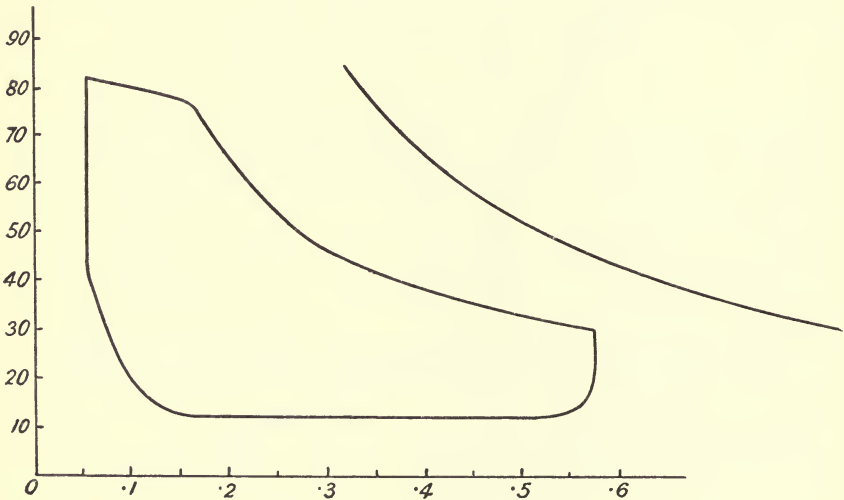

FIG. 59.—Actual indicator diagram.

tion it is obvious that the whole of the missing quantity (Art. 71) is due to condensation. If, however, steam leaks past the valve or engine piston or both, the theory given in Arts. 70 and 72 is not true, since there is no longer a constant weight of steam present in the cylinder after cut-off. Neglecting leakage past the piston and even assuming no leakage past the valve after cut-off, it is evident that, although there will be a constant weight of steam present during expansion, the theory previously given will require modification,¹ and in order to estimate the dryness fraction of the steam at any point on the expansion curve, the total steam present must be made up of cushion steam, cylinder feed, and leakage steam.

If leakage does take place, then the missing quantity will be due both to condensation and leakage. Referring to Fig. 54, which represents an indicator diagram having drawn on it the saturation curve for the cushion

¹ See the First Report of the Steam Engine Research Committee, *Proc. I. Mech. E.*, March, 1905, p. 239.

steam *plus* cylinder feed, *i.e.* when valve leakage is neglected, it will be seen that if leakage occurs the length of *ab* will be unaltered, but the length of *bc*, which represents the missing quantity, will be increased, and, moreover, if leakage continues throughout the expansion, the weight of steam present will be a continuously increasing quantity from cut-off to release.

Great diversity of opinion exists amongst various authorities as to the existence of an appreciable valve leakage in modern steam engines. If it be accepted as true that all valves leak when under working conditions, it is evident that in order to reduce the missing quantity, and therefore obtain greater economy, more attention should be paid to the design of valves instead of endeavouring to reduce the clearance volume to the smallest possible value.

There is a considerable amount of evidence that some valves at any rate do leak, such leakage having been measured by such authorities as Messrs. Callendar and Nicolson, Professor Capper, Captain Sankey and others; a brief review of some of the results obtained will be instructive.

Professor Callendar and Nicolson¹ give their opinion of the way in which leakage takes place through slide valves in the following words:—

“So long as the valve is stationary, the oil film may suffice to make a perfectly tight joint; but as soon as it begins to move, the oil film becomes broken up and partly dissipated. Water is being continually condensed on the colder parts of the surface exposed by the motion of the valve. This water works its way through, and breaks up the oil-film under the combined influence of the pressure and the motion. The continual evaporation taking place in the exhaust tends to maintain the leaking fluid in the state of water. The exhaust steam from the cylinder has the same tendency. . . . It is not improbable that the quantity of water which can leak through a given crack under the given difference of pressure, may be from twenty to fifty times greater than the quantity of steam which can leak under similar conditions. This agrees with well-known facts in regard to leakage, and explains how it is that the leakage in the form of water is so great. . . . An explanation is thus furnished of a possible form of leakage, indirectly due to condensation and re-evaporation, so many times greater than steam leakage, which, alone, engineers have been in the habit of contemplating, that it might well claim attention on its own merits, apart from the very limited number of valves on which it has hitherto been possible to make direct experiments.

“The analysis of a large number of observations, in addition to the few made by the authors, leads to the conclusion that all valves leak more or less when in motion, and that in many cases the greater part of the missing quantity is to be attributed to leakage of this description. Whatever the precise manner in which the leak takes place, it appears to be nearly proportional to the difference of pressure and to be in most cases independent of the speed. In any case it appears probable that the leakage is connected in some way with the condensation taking place on the valve surfaces. If so, it may evidently be greatly reduced, if not entirely cured, by jacketing, or otherwise heating the valve seat, to minimize the condensation.

“These views have an important bearing on the design of valves. For low-speed engines, separate steam and exhaust-valves should possess

¹ See *Proc. Inst. C. E.*, 1897-8, vol. cxxxi. p. 179.

advantages over the ordinary slide valve. The superiority of the compound engine would also appear to be partly due to the great reduction of possible leakage."

From their results with slide valves, Messrs. Callendar and Nicolson state the law of leakage in pounds per hour as

$$\frac{\text{Diff. of press. on the two sides of the valve} \times \text{perim. of steam port}}{\text{Mean overlap}} \times 0.02$$

Professor Capper measured the leakage by blocking up the steam ports of the slide valve, driving the engine at different speeds by external power with steam admitted to the steam chest at varying pressures, and condensing and weighing the steam which leaked past the valve. The conclusions he arrived at may be briefly summed up as follows¹ :—

Effect of Steam Jacket.—The leakage when the barrel of the cylinder was warmed by means of a steam jacket was considerably less than when unjacketed.

Effect of Lubrication.—There is a distinct reduction in leakage when the sliding surfaces are well lubricated over the corresponding leakage with scant lubrication.

Effect of Pressure.—When the valve is stationary, and in mid-position, the leakage is approximately proportional to the steam pressure. When the engine is running, however, the leakage does not increase so rapidly as the pressure, and the higher the speed the larger does this divergence become; hence, much of the leakage must be in the form of moisture condensed on the valve face and re-evaporated as it passes over into the exhaust. It will be noted that this confirms Callendar and Nicolson's conclusions, although they found that the leakage was practically independent of speed.

Effect of Wire-drawing.—The dry steam used was wire-drawn between the main steam pipe and the steam chest, and it was found that in all cases there was a sensible reduction in leakage as a result of superheating the steam and therefore reducing the amount of condensation.

Effect of Speed.—The leakage was consistently less at 250 revolutions per minute than at 50 revolutions per minute. This may be partly due to a more perfect spreading of the oil film at the higher speeds, or it may be due to the reduced time allowed for condensation and re-evaporation, or to a combination of the two. This clearly shows that in these experiments, leakage was not produced by a lifting of the valve from its seat when working, but by a more or less steady flow of moisture or steam between the valve and the slide face.

Effect of Overlap.—The persistent and considerable difference between the leakage when the engine is stationary with the valve in mid-position and when it is running, point strongly to the conclusion that the amount of overlap and its variation has an important effect on the leakage. As already mentioned, Callendar and Nicolson give the mean rate of leakage as

$$\frac{\text{Difference of pressure} \times \text{perimeter}}{\text{Mean overlap}} \times C$$

¹ First Report of the Steam Engine Research Committee, *Proc. Inst. Mech. E.*, March, 1905.

Professor Capper finds that the leakage is not directly proportional to the pressure for *all* speeds, and states that there is reason to doubt whether it is exactly inversely proportional to the overlap; assuming, however, that it is so, then he finds that *C is not constant* although its mean value is 0.02, which is identical with that found by Messrs. Callendar and Nicolson.

Leakage of Piston-Valves and Piston-Rings.¹—Captain H. Riall Sankey measured the leakage past the piston valve and rings of a Willan's engine. He found the above conclusions for a slide valve to be substantially correct for a piston valve, although the value of the constant *C* was 0.003 instead of 0.02.

Warping of the Valve.—A slide valve is a rather intricate casting which when cold may be true and steam-tight, but when heated under working conditions may become distorted and so allow steam to leak past. It is well known that a truly cylindrical shape is the least susceptible to warping, and that therefore the probable warping of a piston valve could be less than that of a slide valve. There is some evidence to show that warping may be wholly or partially the cause of leakage by the fact that the value of *C* found by Captain Sankey was 0.003 as against 0.02 for a flat valve.

From tests on a piston valve Mr. H. Denzil Lobley² found that the leakage was very small, and in the particular valve tested would account for a negligible proportion of the missing quantity.

Professor Mellanby³ also brings forward considerable evidence to show that valve leakage may account for a large proportion of the missing quantity. For instance, in Trial No. 95, which has already been quoted in Art. 68, the highest temperature of the steam was 357° F. and the mean temperature was 284° F. The mean temperature of the cylinder wall was 335° F., hence the maximum temperature range of the walls could not be more than $2(357 - 335) = 44^\circ$ F. Using the method of Art. 68 (p. 111) it would appear that this temperature range at a speed of 60 revolutions per minute would result in 555 pounds being the maximum amount of steam that could be condensed per hour. Now the actual missing quantity near cut-off was, for this trial, 753 pounds, hence it would appear that the remaining 753 - 555 or 198 pounds represents the minimum amount of valve leakage per hour. It will also be noted that in this trial the mean temperature of the cylinder walls (335° F.) is considerably higher than that of the steam (284° F.).

He also found that in all trials, both jacketed and unjacketed, the apparent re-evaporation during expansion in the high-pressure cylinder was less when jacketed than when unjacketed. It is difficult to see how this can be so unless the view be accepted that the missing quantity is largely due to leakage and that the steam in the cylinder is dry before leakage takes place.

The experiments enumerated above have been made on a few valves only; hence one is justified in saying, that before a definite law of valve

¹ See discussion on First Report of Steam Engine Research Committee, *Proc. I. Mech. E.*, March, 1905, p. 275.

² *The Engineer*, Feb. 9, 1912.

³ See "Effect of Steam-Jacketing of a Compound Engine," *Proc. I. Mech. E.*, June, 1905.

leakage can be stated it will be necessary to make numerous tests of different types of valves constructed of cast-iron and other materials under various conditions of working. In a physical sense it is difficult to see how all valves can leak, considering the present state of perfection attained in modern workshop practice, or that valves should leak more than stuffing boxes, etc. The elucidation of the vexed problem of valve leakage is beset with enormous difficulties, and because a certain valve may be found to leak in any particular engine it does not necessarily follow that the same type of valve will leak when fitted to another engine working under similar or under different conditions. For further information on this subject the reader is referred to a paper by Professor A. L. Mellanby on "Surface Condensation in Steam Cylinders," read before the Institution of Engineers and Shipbuilders in Scotland, on December 21, 1911.

75. The most Economical Ratio of Expansion.—Consider first of all the theoretical indicator diagram in which clearance is neglected and the expansion assumed to be hyperbolic (Art. 61). The work done per cubic foot of steam admitted to the engine cylinder is, by Art. 61,

$$W = 144\{p_1(1 + \log_e r) - r \cdot p_b\} \text{ foot-pounds} \dots (1)$$

where p_1 = initial pressure in pounds per square inch, absolute
 p_b = back " " " " "
 r = ratio of expansion

The value of r which makes this a maximum is obtained by putting

$$\frac{dW}{dr} = 0, \text{ hence}$$

$$\frac{dW}{dr} = \frac{p_1}{r} - p_b = 0$$

or
$$r = \frac{p_1}{p_b} \dots (2)$$

The problem is not so simple as this, however, in the actual engine. In the first place, there will be less work done on account of initial condensation. Let w represent this loss due to condensation, then the work done per cubic foot of steam may be written

$$W = 144p_1(1 + \log_e r) - 144r \cdot p_b - w \dots (3)$$

$$\frac{dW}{dr} = 144 \frac{p_1}{r} - 144p_b - \frac{dw}{dr} = 0 \text{ for a maximum}$$

or
$$\frac{dw}{dr} = 144 \left(\frac{p_1}{r} - p_b \right) \dots (4)$$

For non-condensing engines Mr. P. W. Willans finds that the best ratio of expansion is given by $r = \frac{p_1}{25}$ for a simple engine and $r = \frac{p_1 - 10}{25}$ for a compound engine.¹ Taking $r = \frac{p_1}{25}$ and $p_b = 17$ for a non-condensing engine and substituting in (4) we find

$$\frac{dw}{dr} = 144(25 - 17) = 8 \times 144 = 1152$$

¹ Proc. Inst. C. E., 1887-8, vol. xciii.

Integrating we have

$$w = 1152r + a \text{ constant} \dots \dots \dots (5)$$

This is the equation to a straight line, or in other words, on this theory the loss due to condensation is a linear function of the ratio of expansion, the effect of condensation being to increase the back pressure by 8 pounds per square inch.

In addition to the loss due to condensation there will be a further reduction in the work available as a result of engine friction. Suppose friction to be equivalent to a back pressure of f pounds per square inch, and writing c for the equivalent back pressure due to condensation, we have the net work available per cubic foot of steam,

$$W = 144p_1(1 + \log_e r) - 144r(p_b + f) - 144(cr + A) \dots (6)$$

$$\frac{dW}{dr} = \frac{144p_1}{r} - 144(p_b + f) - 144c = 0 \text{ for a maximum}$$

$$\frac{p_1}{r} - (p_b + f) - c = 0$$

or
$$r = \frac{p_1}{p_b + f + c} \dots \dots \dots (7)$$

On the above method of reasoning it would therefore appear that the most economical ratio of expansion to adopt for a non-condensing engine is equal to the initial steam pressure divided by a constant; as already mentioned, Mr. Willans adopted 25 as the value of this constant for the particular engine he experimented on. In the case of a condensing engine, however, he says¹: "It is hardly possible to define, for a condensing engine, the best ratio of expansion. This question must remain one for each particular engine builder to answer. The useful work obtainable from the steam depends so greatly on the condenser back pressure and on the friction of each individual engine that it is impossible to give any general rule."

76. The Steam Jacket.—The theory of the steam engine when the steam is maintained dry and saturated throughout the expansion has already been given in Art. 59; we will now see how close the actual engine, when fitted with steam jacket, approximates to the ideal case there considered.

When dry saturated steam is admitted to an unjacketed cylinder there is always a certain amount of initial condensation (Art. 67) and the steam will be wet at cut-off. In order to prevent initial condensation when using saturated steam, it is essential that the temperature of the cylinder walls should not be below that of the entering steam, and this condition may be obtained by the application of a suitable steam jacket. Let $abcd$ (Fig. 60) represent the temperature-entropy diagram with unjacketed cylinder walls, the dryness fraction at cut-off being $\frac{bc}{be}$ and at release $\frac{ad}{af}$, the expansion cd being adiabatic. If now a steam jacket be fitted to the cylinder and the steam maintained dry up to cut-off after which the expansion is again adiabatic, the heat supplied to the working steam by the jacket will be represented by the area $cekh$, and the extra amount of work

¹ *Proc. Inst. C. E.*, 1892-3, vol. cxiv.

done by the area $cegd$. If the effect of the jacket is such that the steam is maintained dry throughout the expansion, the total heat supplied by the jacket will be represented by the area $cefh$, and the extra work done by the area $cefd$, the result in either case being an increased efficiency (Art. 59). See also Fig. 56, and the example worked out in Art. 71.

From the published results obtained with steam engines working with and without jackets¹ it appears that the increased efficiency resulting from the use of steam jackets varies from 3 per cent. to 25 per cent. depending

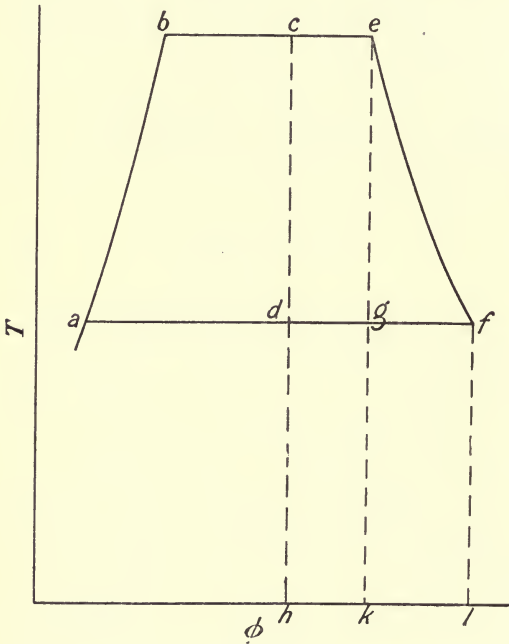

FIG. 60.

on the type of engine. Speaking generally, it appears that jackets are more useful for slow-speed engines than for high-speed engines, and are also useful for simple and compound engines, but their efficiency is doubtful if they are applied to triple or quadruple expansion engines. It has also been found in practice that the more economical an engine is, apart from jacketing, the less advantage is gained by the application of a jacket. If an unjacketed engine uses say 13 pounds of steam per hour per I.H.P. with an initial pressure of about 120 pounds per square inch, the value of a steam jacket will be exceedingly small. By designing an engine

properly, it might be got to such a state of perfection that the economy obtained without a jacket might be so high that the advantage of using a jacket, however perfectly applied, is negligibly small. All conditions which tend to raise the mean temperature of the cylinder walls, and therefore to reduce condensation, such as using superheated steam, employing a late cut-off, working non-condensing, and running the engine at a high speed, diminish the useful effect of a steam jacket.

¹ See the followings papers: Institution of Mechanical Engineers, *Proceedings*. Steam-Jacket Research Committee's Reports: *First Report*, 1889, p. 703; *Second Report*, 1892, p. 418; *Third Report*, 1894, p. 535. Steam-Engine Research Committee's *First Report*, 1905, p. 171. "Effects of Steam-Jacketing upon the Efficiency of a Horizontal Compound Steam Engine," by Prof. A. L. Mellanby, 1905, p. 519. "The Triple Expansion Engine and Engine Trials at the Whitworth Engineering Laboratory, Owens College, Manchester," by Prof. O. Reynolds, *Proceedings of Inst. C. E.*, vol. xcix. p. 152.

Professor A. L. Mellanby obtained the most economical results from his compound engine when the whole of the high-pressure cylinder was jacketed, but only the ends of the low-pressure cylinder.¹ Another important conclusion he arrived at was that one effect of the jacket is to reduce leakage as well as condensation, which agrees with the results obtained by Messrs. Callendar and Nicolson (p. 124). The results obtained with various ratios of expansion both with and without jackets are reproduced in Figs. 61 and 62. In this connection it should be noted

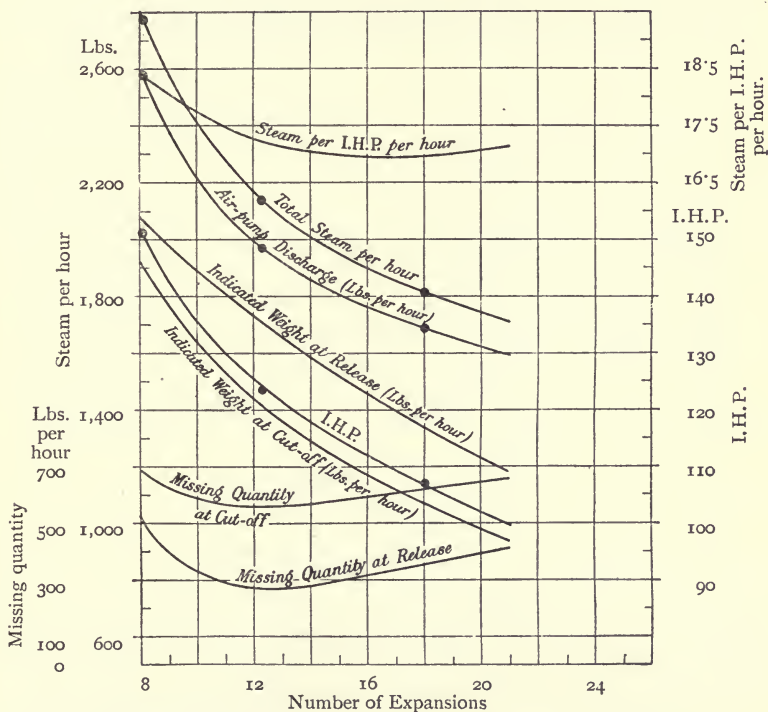

FIG. 61.—Jackets on H.P. cylinder ends and barrel, and on L.P. cylinder ends.

that Professor Mellanby ran the engine at 60 revolutions per minute, *i.e.* at *half* the normal speed for which it was designed, in order that the effect of the jacket should be well defined; this accounts for the steam consumption being fairly high.

77. Effect of Superheating.—The effect of using superheated steam is to reduce condensation, and in this respect the results obtained are much more pronounced than with steam jacketing. Provided that a sufficient degree of superheat is employed, it is practicable to eliminate initial condensation completely, and to ensure dry steam at cut-off,² the

¹ *Proceedings, Inst. M. E.*, 1905, p. 554.

² "Superheated Steam Engine Trials," by Prof. W. Ripper, *Proceedings Inst. C. E.*, vol. cxxviii.

resulting efficiency being very much greater than thermodynamic reasons would imply (Art. 58). If this condition is obtained it will be evident that the steam will be drier at release than if saturated steam is used, hence there will be less heat extracted from the cylinder walls during exhaust, and during compression the temperature will be maintained at a higher value, it being fair to suppose that the cushion steam will be more or less superheated. The net result is, that although the temperature of the walls will be lower than the entering superheated steam, they will be dry; and further, the reduced amount of heat absorbed by the walls during admission will only reduce the temperature of the steam, and condensation

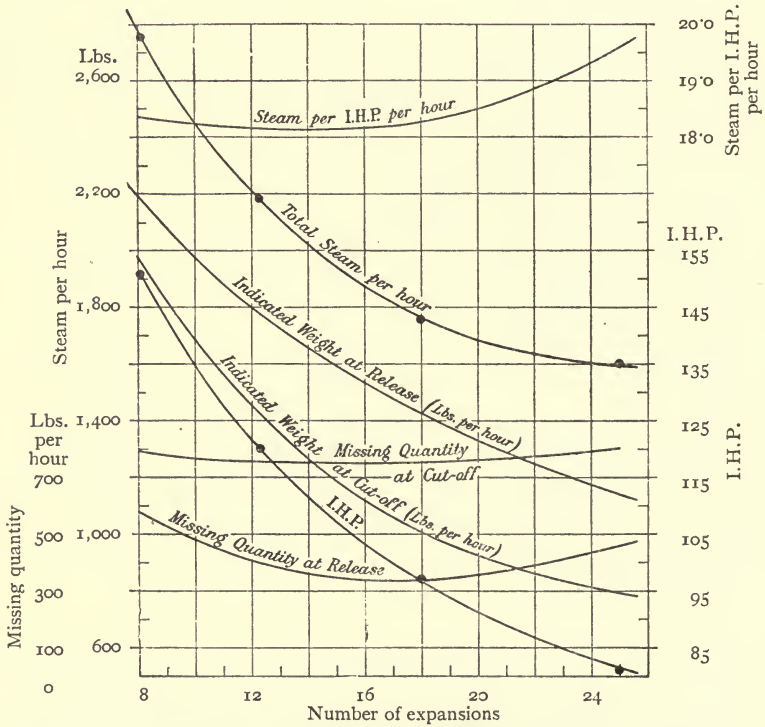

FIG. 62.—No jackets.

will be only possible when the temperature of saturation is reached. It will be evident then, that by using a sufficiently high degree of superheat the walls may be kept dry up to cut-off, and their mean temperature considerably increased. It should be noted that the heat exchanges between dry walls and superheated steam are much less than if moisture is present (Art. 67).

The use of superheated steam also conduces to greater economy, because the valve faces are maintained at a higher temperature, and being dry, there will be less possibility of valve leakage in the form of moisture. If Callendar and Nicolson's suggestion as to the manner in which valve

leakage takes place is correct (Art. 74), it will follow that its magnitude will be greatly reduced when superheated steam is used, and that the reduction of the missing quantity will be due to both the suppression of initial condensation, and to the reduction of valve leakage; but further experiments are necessary before this point can be definitely established.

Some interesting results on the effect of superheating with Belliss and Morcom engines will be found in Mr. R. T. Smith's remarks in the discussion on the First Report of the Steam Engine Research Committee¹ from which the following particulars are taken.

Fig. 63 shows the effect of varying degrees of superheat on the steam consumption per kilowatt hour of seven engines, each coupled to a dynamo, the output ranging from 220 to 1500 kw. They were all non-jacketed condensing engines, and were all tested at full load, one of them (F_2) being also tested at three-quarter load. The interesting result is, that if all the curves are produced sufficiently far, they will be found to meet very nearly in one point, namely 400° of superheat, showing that if one could only use enough superheat all engines of this type, of whatever size, were about equally efficient. From a large number of experiments on the engine marked A in Fig. 63, a series of curves have been drawn in Fig. 64, giving the pounds of steam per B.H.P. hour passing through the engine at all loads up to full load with saturated steam, and also for 50° to 350° F. superheat. These curves get flatter as the superheat increases, showing that, when sufficient superheat is used, an engine of this type tended to become equally efficient at all loads.²

78. Diagram Factors.—The "diagram factor" has been defined in Art. 61, as

$$e = \frac{\text{actual mean effective pressure}}{\frac{p_1}{r}(1 + \log_e r) - p_b}$$

where p_1 = the absolute steam-chest pressure, and p_b the back pressure; in multiple expansion engines the numerator in the above expression will be the mean effective pressure referred to the low-pressure cylinder, *i.e.* the mean pressure on a single piston equal in area to that of the low-pressure cylinder, and which will develop the same power as the several actual cylinders. The diagram-factor may therefore be expressed in terms of the indicated horse power as follows:—

$$e = \frac{\text{I.H.P.} \times 33,000}{\left\{ \frac{p_1}{r}(1 + \log_e r) - p_b \right\} LAN}$$

where L = stroke in feet, A = area of low-pressure cylinder in square inches, and N = number of working strokes per minute.

The value of e depends upon the type of engine, *i.e.* whether simple or

¹ *Proceedings Inst. Mech. E.* 1905, p. 300.

² For further particulars on the use of superheated steam the reader is referred to the following papers:—Institution of Marine Engineers, "Marine Engines and Superheated Steam," by Mr. A. F. White, in the *Marine Engineer and Naval Architect*, Dec. 1909. Institution of Naval Architects, "Superheaters in Marine Boilers," by Mr. Harold E. Yarrow, read March 28, 1912, and reproduced in *Engineering of April 5, 1912. Proceedings Inst. C. E.*, vol. cxxviii., "Superheated Steam Engine Trials," by Prof. W. Ripper.

compound, jacketed or unjacketed, high-speed or low-speed, etc. The

Set.	Kw. output of generator coupled to engine.	Load at test.	Stop valve steam press. Lbs. per sq. inch.	Vacuum at engine. Inches of Mercury.	Date of Test.
A	208	Full	155	26	Jan. 1904.
B	220	"	175	25	Nov. 1902.
C	308	"	190	25	Dec. 1902.
D	362	"	162	25.8	Feb. 1903.
E	500	"	150	26	Mar. 1904.
F ₁	700	"	190	27	Jan. 1905.
F ₂	580	"	192	27	Feb. 1905.
G	1456	Full	183	26	July & Aug. 1903.

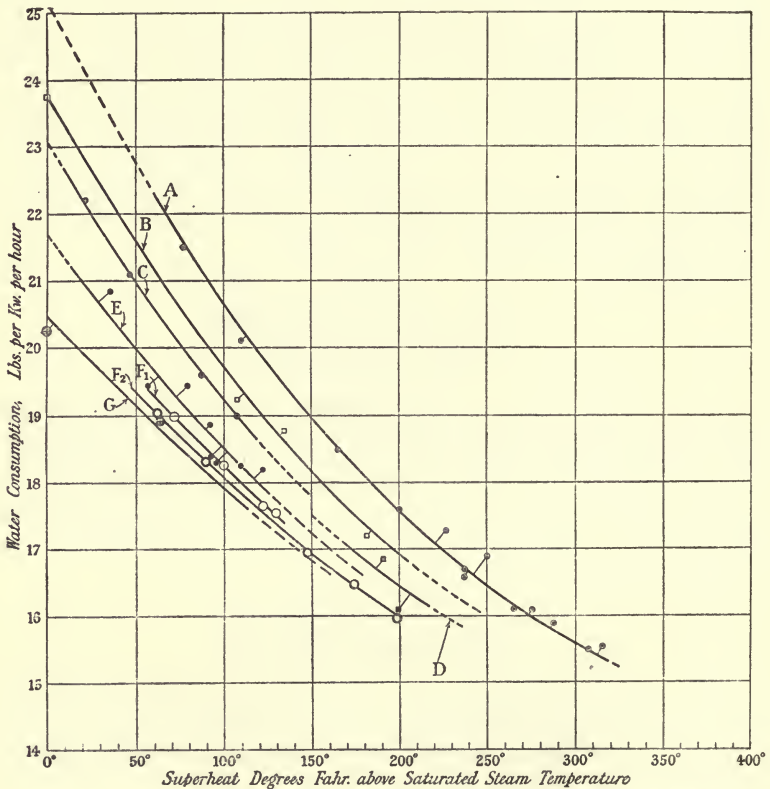

FIG. 63.—Non-jacketed quick-revolution triple-expansion condensing engines, using superheated.

(Experiments on Messrs. Belliss and Morcom's engines.)

difficulty experienced in estimating the diagram factor for a new engine lies in the uncertainty of the probable value of the back pressure. For

the same condenser pressure, the actual back pressure in the engine

(Engine A of Fig. 63), showing effect of superheat on steam-consumption at varying loads.

The percentage figures indicate the increase in lbs. of water per B.H.P.-hour over full load consumption.

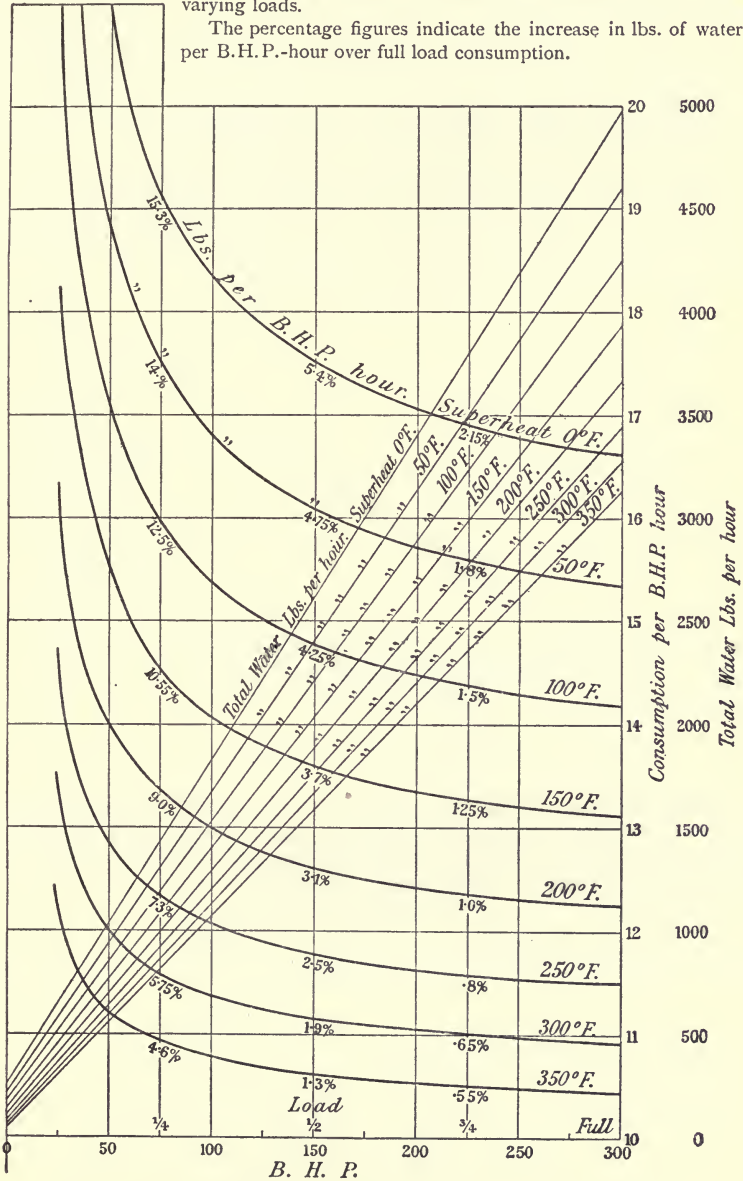

FIG. 64.—Non-jacketed quick-revolution triple-expansion engine.

cylinder will not be a constant quality; it will usually vary with the speed

of the engine, the initial pressure, and the ratio of expansion. If the initial pressure or speed of the engine, or both, be increased, it is evident that more steam will be passed through the engine, the back pressure will usually rise, and e is at once affected.

Mr. C. H. Wingfield¹ has shown that if a quantity which he calls the *virtual* back pressure is substituted for the *actual* back pressure, this virtual back pressure, which can be found from trials of similar engines, is not only independent of the speed and number of expansions, but the diagram factor e is less affected by the expansions, and scarcely at all by the speed. He applies his method to the results obtained by Mr. P. W. Willans in his condensing engine trials.² The virtual back pressure is obtained by plotting the actual mean effective pressure, and the theoretical mean pressure as shown in Fig. 65. The intercept of the resulting straight line on the vertical axis gives this virtual back pressure.

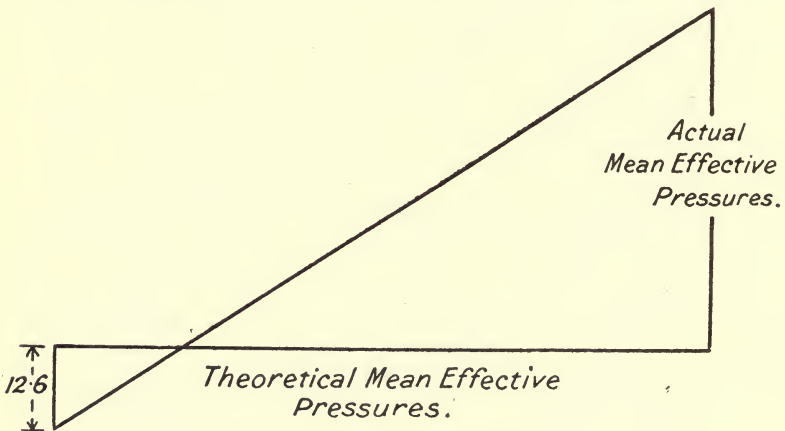

FIG. 65.—Virtual back pressure.

With a constant number of expansions ($r = 4.82$) he finds the virtual back pressure to be 12.6 pounds per square inch, absolute, and the diagram factor e to vary from 0.69 at 400 revolutions per minute to 0.72 at 200 revolutions per minute. The slight reduction of e with increase of speed is in all probability due to the influence of wire-drawing.

With a constant speed of 400 revolutions per minute, the virtual back pressure was 3 lbs. per square inch absolute, and with the expansions used by Mr. Willans the values of the diagram factor are—

Expansions.	e
4.82	0.69
10.00	0.77
15.55	0.83

¹ *Engineering*, Oct. 20, 1893.

² *Proceedings Inst. C. E.*, vol. cxiv. 1892-1893.

The values of the diagram factor obtained by Prof. A. L. Mellanby on a compound engine¹ are shown in Fig. 66 for the engine when both jacketed and unjacketed, together with the actual and theoretical mean effective pressures. This diagram shows very clearly how the diagram factor varies with the number of expansions.

From the results obtained in practice,² it appears that the probable values of e for various engines are: for a compound marine engine, about 0.7; for a triple expansion marine engine about 0.635; for a horizontal Corliss engine without jackets, from 0.76 to 0.86. For a locomotive it is

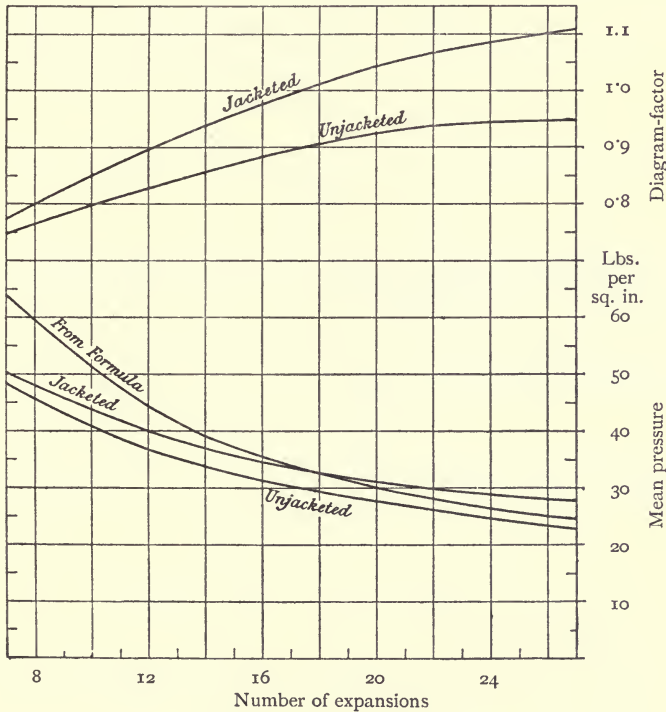

FIG. 66.—Diagram factor.

difficult to fix any value, but at a high piston speed of from 700 to 800 feet per minute, e appears to be about 0.63, and at slow speeds of about 170 feet per minute about 0.8.

In all cases, for a given engine, the lower the speed the greater is the value of the diagram factor; this is no doubt due to there being less wire-drawing and more time for initial condensation to take place, the subsequent re-evaporation during expansion increasing the mean pressure at the lower speeds, and to the lower compression pressure.

79. Steam Consumption—the Willans Law.—It may be shown

¹ *Proceedings Inst. M. E.*, June, 1905, p. 535.

² See a paper by C. H. Innes, M.A., *Practical Engineer*, June 17, 1892.

from theoretical considerations that, provided the ratio of expansion remains constant, *i.e.* if the engine governs by throttling, the steam consumption is a linear function of the indicated horse-power.

Let W = steam consumption in pounds per hour, and P the indicated horse-power, then using the same notation as before—

$$p_m = p_1 \left(\frac{1 + \log_e r}{r} \right) - p_b$$

Since r remains constant, this may be written

$$p_m = C p_1 - p_b$$

$$P = \frac{(C p_1 - p_b) LAN}{33,000}$$

$$\therefore p_1 = \frac{1}{C} \left(\frac{33,000 P}{LAN} + p_b \right) \dots \dots \dots (1)$$

Let w_1 be the weight of 1 cubic foot of steam at absolute pressure p_1

$$\text{then } W = \frac{60ALN}{144r} \cdot w_1 \dots \dots \dots (2)$$

If w_1 and p_1 be plotted on squared paper using steam tables (p. 480), it will be found that approximately

$$w_1 = a + \beta p_1$$

where a and β are constants.

Substituting for w_1 in (2) we get

$$W = \frac{60ALN}{144r} (a + \beta p_1) \dots \dots \dots (3)$$

Putting (1) in (3) gives

$$W = \frac{60ALN}{144r} \left\{ a + \frac{\beta}{C} \left(\frac{33,000P}{LAN} + p_b \right) \right\}$$

$$= \frac{60ALN}{144r} \left(a + \frac{\beta}{C} \cdot p_b \right) + \frac{60ALN}{144r} \cdot \frac{33,000}{CLAN} \cdot P$$

$$\text{or } W = a + bP \dots \dots \dots (4)$$

where a and b are constants having the values $a = \frac{60ALN}{144r} \left(a + \frac{\beta}{C} p_b \right)$ and

$$b = \frac{60ALN}{144r} \cdot \frac{33,000}{CLAN}$$

This equation $W = a + bP$ is known as the Willans' straight line law, and is found to be sensibly true for all actual engines working with a constant ratio of expansion, as will be evident from the curves given in Fig. 64, and in Mr. Willans' papers already referred to.

EXAMPLES V

1. Estimate the work done per cubic foot of steam in the following cases :—

- (a) When there is no clearance and no compression.
- (b) When the clearance is 0.5 cubic foot and with no compression.
- (c) When the clearance is 0.5 cubic foot and the compression pressure 50 pounds per square inch absolute.

(*d*) When the clearance is 0.5 cubic foot and the compression equal to the initial steam pressure.

In each case assume an initial steam pressure of 100 pounds per square inch absolute and a ratio of expansion of 4.

2. The following particulars are obtained from an indicator diagram taken from the high-pressure cylinder of a compound steam engine fitted with Corliss valves:—

Cut off $\frac{1}{2}$ stroke; at a point on the compression curve the pressure was 50 lbs. abs., and indicated volume 4 cubic feet.

Pressure at a point on expansion curve just after cut-off = 155 lbs. abs., and indicated volume = 7.2 cubic feet.

Pressure at $\frac{1}{2}$ stroke on expansion curve = 112 lbs. abs.

Pressure at release = 62 lbs. abs., and indicated volume = 17.5 cubic feet.

The diameter of the cylinder is 28 inches and stroke 4 feet, the clearance volume being 7 per cent. of the stroke volume and the cylinder feed 2.58 pounds per stroke with 150 working strokes per minute. Estimate the dryness fraction and missing quantity in pounds per hour (*a*) at cut off, (*b*) at $\frac{1}{2}$ stroke, (*c*) at release, given—

p	155	112	62	50
v	2.92	3.98	6.95	8.51

3. Dry steam is admitted to an engine cylinder at 60 pounds per square inch absolute, and the condensation during admission is 20 per cent. of the whole steam supply. During expansion three-quarters of the heat absorbed by the cylinder walls during admission is returned to the steam at a uniform rate as the temperature falls. If the expansion be complete and the back pressure be 4 pounds per square inch absolute, find the dryness fraction at the end of expansion, and, assuming the exhaust steam to be homogeneous in quality, find its dryness fraction at the end of the exhaust stroke. Neglect clearance and all heat losses, and assume the specific heat of water to be constant and equal to unity. Use the steam tables given on p. 480.

4. A steam engine cylinder is $33\frac{1}{2}$ inches diameter and the piston has a stroke of 3 feet 3 inches. The engine develops 600 I.H.P. at 100 revolutions per minute. Assuming a diagram factor of 0.82 what is the ratio of expansion if the initial steam pressure is 155 pounds per square inch absolute and the back pressure 2 pounds per square inch absolute?

CHAPTER VI

COMPOUND EXPANSION

80. Advantages of Compound Expansion.—In order to obtain economical results with the high boiler pressures used in modern practice it is necessary to work with a large number of expansions (Art. 75). Several disadvantages attend the use of a single cylinder for this purpose. In the first place, a very early cut-off would be required; and in order to allow for the low release pressure desirable, the volume of the cylinder would have to be large enough to accommodate the large volume occupied by the steam at this pressure. The temperature range of the steam and the loss due to initial condensation would be excessively large (Art. 75). Also since the mean effective pressure on the piston would be a small portion of the initial steam pressure, the diameter of the cylinder would have to be made very large to develop the power required; and further, all the working parts of the engine would have to be made strong enough to withstand the *high initial pressure*. The combined effect would be an engine of excessive size and weight (and therefore cost) which would be uneconomical in working for two reasons, namely, the high steam consumption produced by the excessively large initial condensation, and the comparatively low mechanical efficiency resulting from the large frictional resistance unavoidable with heavy moving parts. In addition to the above disadvantages the variation of the turning movement on the crankshaft would be very great, and in order to reduce the cyclic variation in speed a very heavy fly-wheel would be necessary (Art. 243), which in its turn would again increase the weight of the engine and the frictional resistance at the main bearings and tend to lower the mechanical efficiency still further.

By employing compound or multiple expansion, in which the expansion is carried out successively in two or more cylinders, the initial condensation, and therefore the steam consumption, is reduced, and further, the range of stress on the different pistons is diminished and a more uniform turning moment obtained on the crankshaft.

In the compound engine the expansion takes place in two stages. The high-pressure steam is admitted into the high-pressure cylinder, and after cut-off expands through a certain ratio and is then exhausted from the high-pressure cylinder into the larger low-pressure cylinder in which the expansion is completed. In the triple expansion engine the expansion is carried out in three stages, the successive cylinders being known as the high-pressure, intermediate pressure, and low-pressure cylinders respectively, whilst in the quadruple expansion engines (used in conjunction with the highest boiler pressures) four cylinders are commonly used, the

high-pressure and low-pressure with two intermediate cylinders. In all cases the temperature range of the cylinder walls is reduced, and only the low-pressure cylinder is ever in communication with the low temperature of the condenser.

By employing multiple expansion in this manner the initial condensation is reduced in two ways, the temperature range being reduced to a practical value in each cylinder and also on account of re-evaporation during exhaust, the steam as it enters the successive cylinders is drier than it otherwise would be; further, by a suitable arrangement of crank angles in conjunction with the smaller range of pressure in each cylinder a more even turning moment is obtained on the crankshaft (see Art. 238).

81. Compound Engines without an Intermediate Receiver.

—In this type of engine the steam is exhausted from the high-pressure cylinder directly into the low-pressure cylinder, the two cylinders remaining in communication throughout each stroke, there being continuous

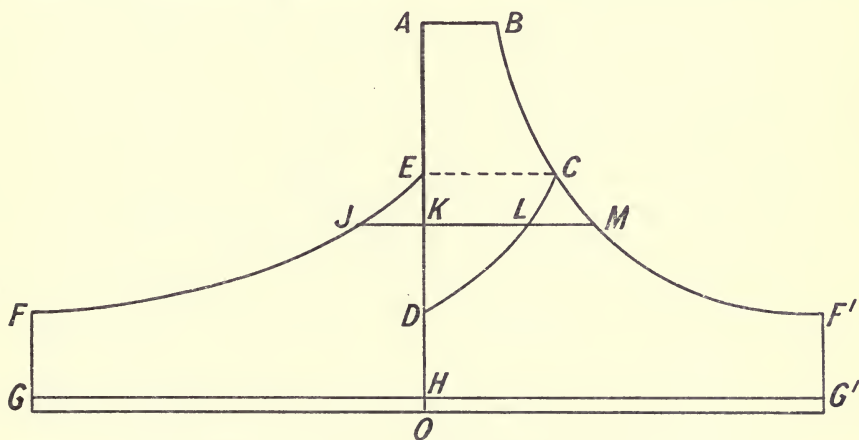

FIG. 67.—Compound diagram without receiver.

expansion in the low-pressure cylinder without an independent cut-off. In this type the cranks must be set either 0° or 180° apart; in the former case both the high-pressure and the low-pressure pistons are attached to a common piston rod and therefore both move together, this type of engine being called the tandem compound. When the cranks are 180° apart the cylinders are arranged side by side, each having its own piston driving a crank. In the case of a vertical engine, when the high-pressure piston is moving downwards, the low-pressure piston is travelling upwards and *vice versa*, and the steam is exhausted from below the high-pressure piston to the under side of the low-pressure piston where the expansion is completed. On the next (upward) stroke of the high-pressure the steam is exhausted from the top of the high-pressure piston to the top of the low-pressure and so on.

The theoretical indicator diagram for this type of engine, commonly called the Woolf type, is shown in Fig. 67. ABCD represents the diagram for the high-pressure cylinder, in which OA is the absolute admission

pressure; cut-off takes place at B and the steam expands down to C followed by exhaust, CD, from the high-pressure cylinder directly into the low-pressure cylinder where the expansion is completed. EFGH represents the diagram for the low-pressure cylinder in which the expansion EF continues down to the required release pressure at F followed by exhaust GH. The release pressure in the high-pressure cylinder, *i.e.* the pressure at C, is the same as the initial pressure (at E) in the low-pressure cylinder and at the end of the exhaust stroke in the high-pressure the pressure is of necessity the same as the release pressure in the low-pressure cylinder, *i.e.* the pressure at D is the same as at F. The two diagrams may be combined by drawing a number of horizontal lines, such as JM between E and D, and making LM equal to JK. The combined diagram ABF'G'H represents the equivalent theoretical indicator diagram which would be obtained by carrying out the expansion in a single cylinder of the same size as the low-pressure cylinder and is equal in area to the sum of the

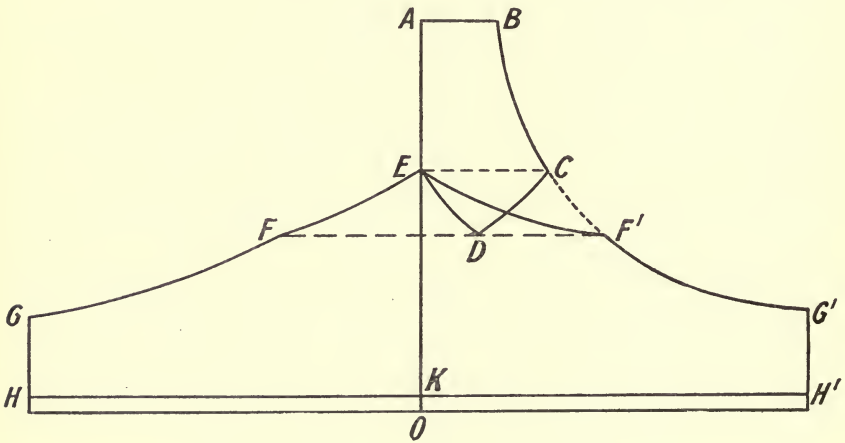

FIG. 68.—Compound diagram with receiver.

areas of the high-pressure and low-pressure diagrams. The mean effective pressure obtained from the combined diagram ABF'G'H is called the mean effective pressure referred to the low-pressure cylinder and in the theoretical diagram shown is equal to

$$\frac{p_1}{r}(1 + \log_e r) - p_b$$

where p_1 is the initial absolute pressure OA, p_b the absolute back pressure OH, and r the ratio of expansion $\frac{HG'}{AB}$ or $\frac{HG}{AB}$.

82. Compound Engines with an Intermediate Receiver.—In this type of engine a receiver is usually fitted between the high-pressure and the low-pressure cylinders. In many cases a separate receiver is not fitted, the steam pipe between the two cylinders answering the same purpose. Fig. 68 shows the compound diagrams of a tandem engine of the receiver type, ABCDE being the high-pressure and EFGHK the low-pressure

diagram. After expansion, BC, in the high-pressure cylinder, the steam is exhausted into the receiver, and during the first portion of the high-pressure exhaust stroke CD, steam is admitted into the low-pressure cylinder from the receiver along the line EF. Steam is then cut-off in the low-pressure cylinder at some point F and the expansion is continued along FG in this cylinder independently of the high-pressure cylinder. After cut-off takes place in the low-pressure cylinder the exhaust stroke in the high-pressure cylinder is completed by compressing the remaining steam into the receiver along DE, until at the end of the stroke the pressure in the receiver (at E) is the same as the release pressure (at C) in the high-pressure cylinder.

In order that the initial pressure (OE) in the low-pressure cylinder may be the same as the release pressure in the high-pressure cylinder, the cut-off in the low-pressure cylinder must occur at a certain fixed point, or in other words, the point D must be so chosen that at the end of compression

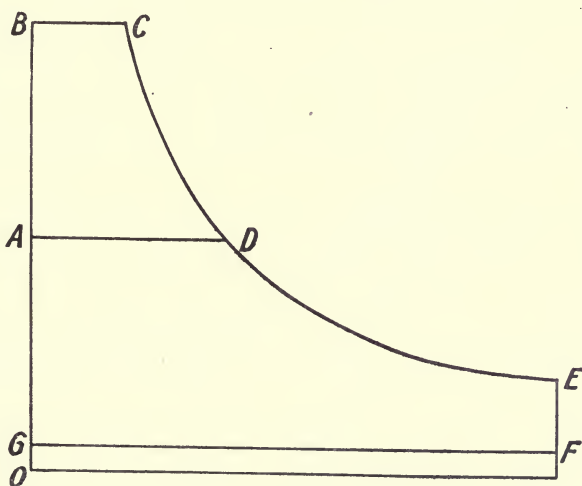

FIG. 69.

into the receiver the pressure is the same as at C; in such cases there is evidently no drop in pressure between release in the high-pressure cylinder and the receiver.

Since the two cylinders are never in direct communication it is evident that the cranks may be set at any required phase angle (usually 90°), and further the temperature range in the high-pressure cylinder, and therefore the initial condensation, are both less than in the case of the Woolf type of engine. The greater the volume of the receiver the less will be the variation in the back pressure of the high-pressure cylinder, *i.e.* the more nearly will CDE approach to a horizontal straight line. In what follows the receiver volume will be assumed infinitely large, in which case the back pressure in the high-pressure and the admission pressure in the low-pressure cylinder will be constant, the combined diagram taking the form shown in Fig. 69, in which ABCD is the high-pressure and ADEFG the low-pressure diagram, the receiver pressure remaining constant and equal to OA.

83. **Ratio of Cylinder Volumes.**—With a given ratio of expansion let ABCDE (Fig. 70) represent the equivalent indicator diagram for one cylinder of the same volume as the low-pressure cylinder; its area will represent the work done by a certain weight of steam and will be equal to the sum of the work done in the high- and low-pressure cylinders. If the total work done is to be equally divided between the two cylinders, the area of the high-pressure diagram ABFG must be made equal to that of the low-pressure diagram GFCDE, and the ratio of cylinder volumes will be

$$\frac{\text{Volume of low-pressure cylinder}}{\text{Volume of high-pressure cylinder}} = \frac{ED}{GF}$$

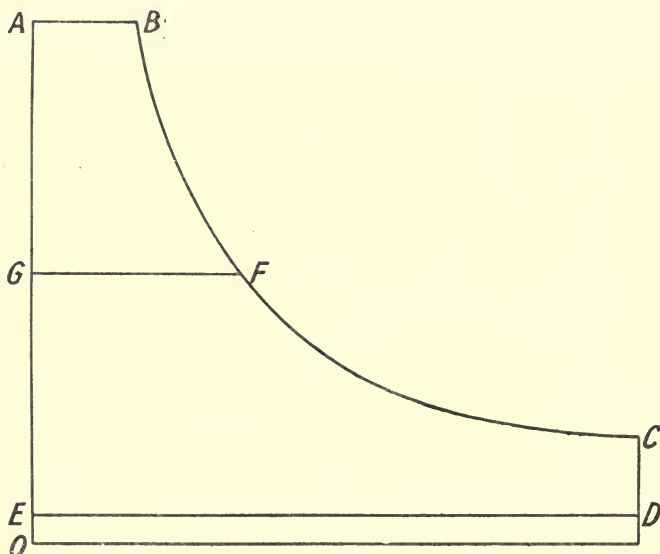

FIG. 70.

If equal distribution of work is not required, it is evident that the ratio may have a large number of values depending upon the position of the line GF.

When designing an engine the size of the low-pressure cylinder is first estimated (Art. 88), and then a suitable volume ratio, obtained from practical experience gained with similar engines, is taken in order to fix the size of the high-pressure cylinder, and the point of cut-off in the high-pressure cylinder is then adjusted in order to obtain the ratio of expansion required.

Let L be the ratio of the low-pressure to the high-pressure cylinder, R the total ratio of expansion required, then the ratio of expansion in the high-pressure cylinder must be

$$r = \frac{R}{L}$$

84. **Effect of varying the Point of Cut-off in the High-**

pressure Cylinder on the Distribution of Work—Cut-off Governing.—The effect of varying the point of cut-off in the high-pressure cylinder and keeping both the cut-off in the low-pressure cylinder and the speed of the engine constant, is to vary the total power developed by the engine. By making the high-pressure cut-off later, more steam is supplied per stroke and the mean effective pressure referred to the low-pressure cylinder is increased, which results in an increased power being developed. The increase of power is not, however, equally distributed between the two cylinders. Neglecting clearance and assuming hyperbolic expansion, the release pressure in the high-pressure cylinder (and therefore the pressure in the receiver for no drop) will be $\frac{p_1}{r}$, where p_1 is the initial pressure and r the ratio of expansion in the high-pressure cylinder. Now as the cut-off is made later, r decreases, hence, the back pressure in the high-pressure cylinder (which is equal to the receiver pressure) increases.

The initial pressure in the low-pressure cylinder is equal to the receiver pressure, and since the number of expansions in this cylinder is not altered, it is evident that the mean effective pressure is largely increased, since its back pressure remains constant and a greater proportion of the increased power will be developed in the low-pressure than in the high-pressure cylinder.

If the engine is governed by varying the point of cut-off in the high-pressure cylinder it will, when running on light load, have an early cut-off, and the number of expansions so obtained in the high-pressure cylinder will be sufficient to ensure a greater proportion of the total power being developed in the high-pressure cylinder; when running light, the power developed in the low-pressure cylinder may be practically nothing.

85. Effect of Throttling the Steam to the High-pressure Cylinder on the Distribution of Work—Throttle Governing.—Consider the combined indicator diagram shown in Fig. 71, in which $abcd$ represents the work done in the high-pressure cylinder and $adefg$ the work done in the low-pressure cylinder. Suppose that in order to meet a reduced load on the engine the steam is throttled down to the pressure oh , the cut-off in each cylinder remaining unaltered. Then $ahkd$ will represent the high-pressure diagram and $adefg$ the low-pressure diagram; the work done in the high-pressure cylinder (area $hkda$) will be less than before, but the work done in the low-pressure cylinder (area $adefg$) will be unaltered.

If, therefore, the engine is governed by throttling the power developed in the low-pressure cylinder will remain practically constant, and when running on light load the power developed in the high-pressure cylinder may be very small. This is the converse to what happens with cut-off governing on the high-pressure cylinder.

86. Effect of varying the Cut-off in the Low-pressure Cylinder on the Distribution of Work.—If the total number of expansions remains the same, *i.e.* with constant cut-off in the high-pressure cylinder, the total amount of work done per pound of steam remains the same, and the effect of varying the point of cut-off in the low-pressure cylinder is merely to alter the distribution of work between the two cylinders. Let $abcde$ (Fig. 72) represent the theoretical indicator diagram referred to the low-pressure cylinder; for any particular cut-off g , in the low-pressure cylinder, the area $afgde$ represents the work done in that

cylinder, and the area $fbcg$ the work done in the high-pressure cylinder.

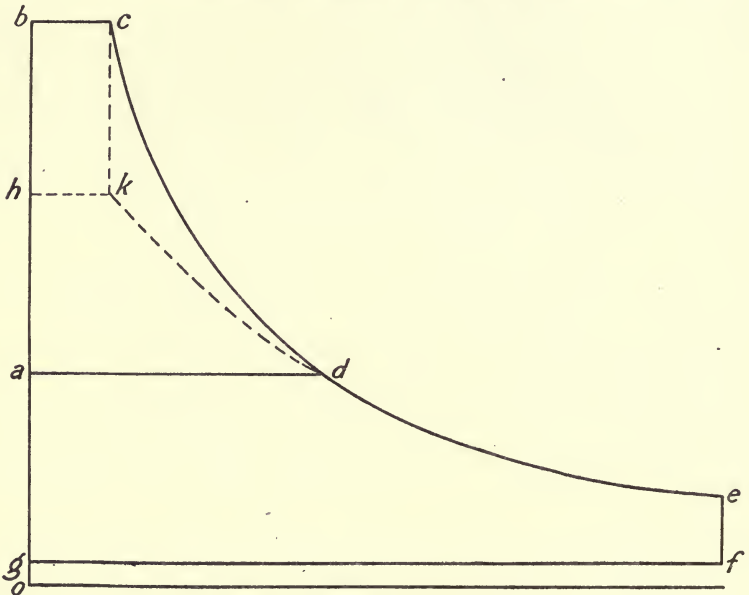

FIG. 71.—Effect of throttling.

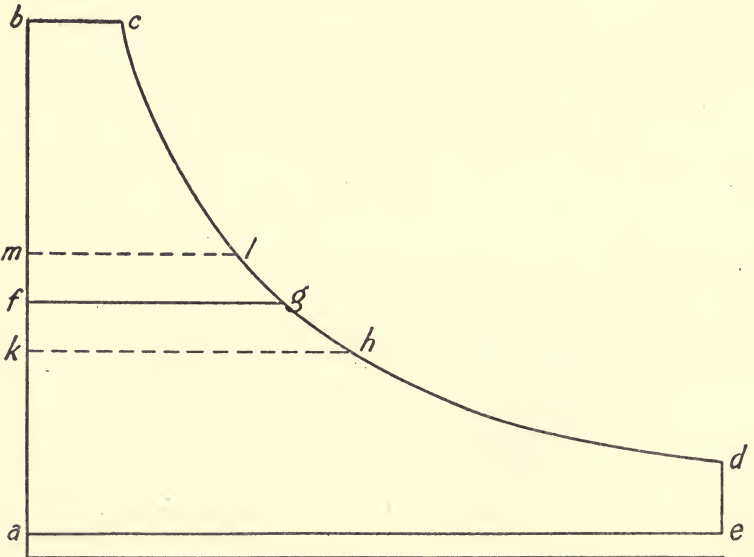

FIG. 72.—Effect of varying the cut-off in low-pressure cylinder.

If now the cut-off in the low-pressure be made later, at h , the work

done in this cylinder will be reduced by the area $fg hk$, and that done in the high-pressure cylinder will be increased by the same amount; $kbch$ will now be the high-pressure diagram and $akhde$ the low-pressure diagram.

Conversely, if the cut-off is made earlier, at l , the work done in the low-pressure cylinder will be increased to the area $amlde$, but the work done in the high-pressure cylinder will be reduced to the area $mbcl$. In order to increase the work done in the low-pressure cylinder, therefore, the cut-off should be made *earlier*, and *vice versa*.

Making the cut-off take place later in the low-pressure cylinder has the effect of increasing the mean pressure in the receiver, and therefore the back pressure in the high-pressure cylinder, which results in less work being done in the high-pressure, and more in the low-pressure cylinder. Further, if there is a drop in pressure between release in the high-pressure cylinder and the receiver, it will be reduced, and there will be some cut-off at which the drop will be entirely eliminated. It will be evident, therefore, that by choosing a suitable ratio of cylinder volumes and cut-off in the low-pressure cylinder, it is possible to have equal distribution of work between the two cylinders and no drop.

87. Initial Loads on the High-pressure and Low-pressure Pistons.—The initial load on the piston is the difference between the total forces exerted by the steam on the two sides of the piston. Thus, on the high-pressure piston the initial load will be (neglecting the area of the piston rod)

Area of high-pressure piston \times (initial steam pressure — receiver pressure)
and on the low-pressure piston

Area of low-pressure piston \times (receiver pressure — back pressure)

It will frequently happen that if equal distribution of work is allowed between the cylinders, the initial loads will be unequal and *vice versa*. When designing an engine it is an advantage to have the initial loads equal, in which case the distribution of work may be unequal, as will be evident from the following example. The ratio of cylinder volumes should be so chosen that both the work done in the two cylinders and the initial loads on the pistons are approximately equal.

Suppose the initial steam pressure in the high-pressure cylinder is 100 pounds per square inch absolute, the total number of expansions 10, back pressure 4 pounds per square inch absolute, and the ratio of cylinder volumes 3.

Let x be the receiver pressure in pounds per square inch absolute. Then, since the area of the low-pressure cylinder will be 3 times that of the high-pressure cylinder for equal strokes, for equal initial loads we have

$$100 - x = 3(x - 4)$$

$$\therefore x = 22 \text{ pounds per square inch absolute}$$

Assuming complete hyperbolic expansion, the ratio of expansion in the high-pressure cylinder will be

$$\frac{100}{22} = 4.55$$

and in the low-pressure cylinder

$$\frac{10}{4.55} = 2.2$$

The mean effective pressure in the high-pressure cylinder will be—

$$\begin{aligned} & \frac{100}{4.55} (1 + \log_e 4.55) - 22 \\ & = 22(1 + 1.5151) - 22 \\ & = 33.33 \text{ pounds per square inch} \end{aligned}$$

The mean effective pressure in the low-pressure cylinder will be—

$$\begin{aligned} & \frac{22}{2.2} (1 + \log_e 2.2) - 4 \\ & = 10(1 + 0.7885) - 4 \\ & = 13.88 \text{ pounds per square inch} \end{aligned}$$

Hence the ratio

$$\frac{\text{Work done in high-pressure cylinder}}{\text{Work done in low-pressure cylinder}} = \frac{33.33}{3 \times 13.88} = \frac{1}{1.24}$$

EXAMPLE 1.—In a two cylinder compound engine, the admission pressure to the high-pressure cylinder is 105 pounds absolute, cut-off 0.6 stroke. The release pressure in the low-pressure cylinder is 12 pounds absolute and the condenser pressure 3 pounds absolute. If the initial loads on the pistons are equal and the curve of expansion is $p v^{1.2} = \text{constant}$, estimate the cylinder volume ratio, the mean pressure in the receiver, the point of cut-off in the low-pressure cylinder, and the ratio of the work done in the two cylinders. (L.U.)

Let R = total ratio of expansion, then, assuming a continuous expansion curve,

$$\begin{aligned} 105 \times 1 &= 12 \times R^{1.2} \\ \text{from which } R &= 6.095 \\ \therefore \text{cylinder ratio} &= 6.095 \times 0.6 = 3.657 \end{aligned}$$

Let x = mean receiver pressure in pounds per square inch absolute. For equal initial loads,

$$\begin{aligned} 105 - x &= 3.657(x - 3) \\ x &= 24.9 \text{ pounds absolute} \end{aligned}$$

Let n = ratio of expansion in low-pressure cylinder, then

$$\begin{aligned} 24.9 \times 1 &= 12 \times n^{1.2} \\ \text{from which } n &= 1.838 \end{aligned}$$

\therefore cut-off in low-pressure cylinder = $\frac{1}{1.838} = 0.544$ of the stroke.

Let p_2 = the absolute release pressure in high-pressure cylinder

$$105 \times 1 = p_2 \times \left(\frac{1}{0.6}\right)^{1.2}$$

from which $p_2 = 56.87$ pounds per square inch absolute

The theoretical indicator diagram is shown in Fig. 73, in which *abcde*

is the high-pressure and $afghk$ the low-pressure diagram. It should be noticed that there is a drop in pressure between the high-pressure release

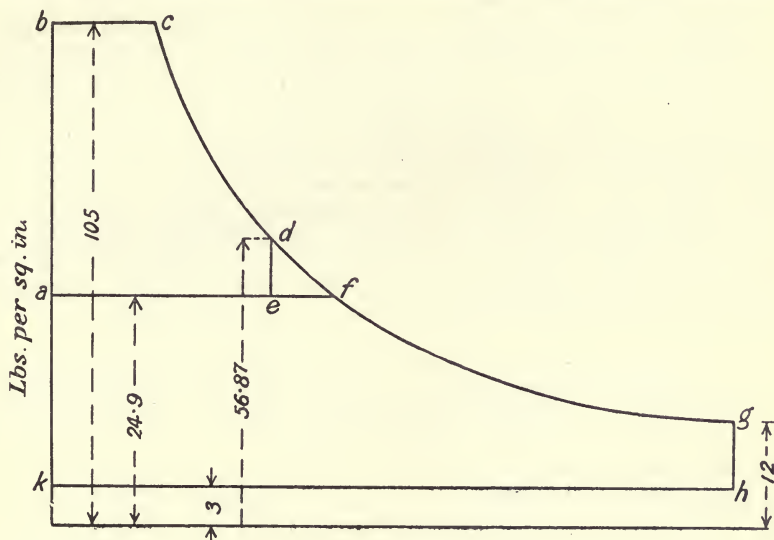

FIG. 73.

and the mean receiver pressure of amount $56.87 - 24.9 = 31.97$ pounds per square inch.

To find the Distribution of Work between the Cylinders.—The mean effective pressure in the high-pressure cylinder is

$$\begin{aligned} & \frac{105 \times 1 + \frac{105 \times 1 - 56.87 \times \frac{1}{0.6}}{1.2 - 1}}{\frac{1}{0.6}} - 24.9 \\ &= \frac{105 + 51}{1.66} - 24.9 \\ &= 68.8 \text{ pounds per square inch} \end{aligned}$$

The mean effective pressure in the low-pressure cylinder is

$$\begin{aligned} & \frac{24.9 \times 1 + \frac{24.9 \times 1 - 12 \times 1.838}{1.2 - 1}}{1.838} - 3 \\ &= \frac{24.9 + 14.2}{1.838} - 3 \\ &= 18.25 \text{ pounds per square inch} \end{aligned}$$

Hence,

$$\frac{\text{work done in high-pressure cylinder}}{\text{work done in low-pressure cylinder}} = \frac{68.8}{3.657 \times 18.25} = 1.03$$

In this example, the approximately equal distribution of work and the equal initial loads are only obtained by the "drop" between the high-pressure release and the receiver.

88. Method of estimating the Cylinder Dimensions in order to develop a Given Power.—The usual method is as follows: The ratio of expansion is first decided, and then, assuming hyperbolic expansion, the mean effective pressure referred to the low-pressure cylinder is calculated, a suitable diagram factor (Art. 78) being employed. The mean piston speed is next decided upon, and the area of the low-pressure piston calculated. A cylinder volume ratio is next selected, and the areas of the high-pressure and intermediate cylinders estimated. The stroke of the several pistons, invariably being equal, is next decided with reference to the mean piston speed and the revolutions per minute at which the engine is to run. The following table gives average values of cylinder ratios, etc. for different types of engines:—

Type of engine.	Initial pressure, lbs. per sq. in. (gauge).	Total number of expansions.	Cut-off in high-pressure cylinder.	Ratio of cylinder volumes, High pressure cylinder = 1.
<i>Compound engines—</i>				
Light engines . . .	100-140	5-7	0.5-0.7	1 : 3.2-3.8
Heavy engines . . .	90-100	5-8	0.5-0.7	4-4.6
Triple expansion . .	150-220	9.5-12	0.6-0.7	1 : 2.6 : 6.8 to 1 : 2.2 : 7.2
Quadruple expansion	190-220	10-13	0.65-0.72	1 : 2 : 4 : 8 to 1 : 2.2 : 4.4 : 9.2

EXAMPLE 1.—Determine the cylinder diameters of a horizontal compound steam engine with trip-gear to develop 600 indicated horse-power under the following conditions: Pressure in steam chest 155 pounds per square inch absolute, vacuum 26 inches, number of expansions 12, diagram factor 0.82, piston speed 650 feet per minute, cut-off in high-pressure cylinder $\frac{1}{3}$ stroke. Determine also the point of cut-off in the low-pressure cylinder, and compare the work done in the two cylinders when the initial loads are approximately equal.

$$\text{The cylinder ratio will be } L = \frac{R}{r} = \frac{12}{3} = 4.$$

Hence if A_2 and A_1 denote the area (in square inches) of the low-pressure and high-pressure cylinders respectively,

$$\frac{A_2}{A_1} = 4 \text{ the strokes being made equal}$$

Referred to the low-pressure cylinder

$$\begin{aligned} p_m &= 0.82 \left\{ \frac{155}{12} (1 + \log_e 12) - 2 \right\} \\ &= 0.82 \left\{ \frac{155}{12} \times 3.48 - 2 \right\} \\ &= 0.82 \times 43 = 35.3 \text{ pounds per square inch} \end{aligned}$$

Hence

$$\frac{A_2 \times 35.3 \times 650}{33,000} = 600$$

$$A_2 = \frac{600 \times 33,000}{35.3 \times 650}$$

$$= 861 \text{ square inches}$$

or

$$d_2 = \sqrt{\frac{861}{0.7854}} = 33 \text{ inches}$$

Since $A_2 = 4A_1$, it follows that $d_2 = 2d_1$, hence the diameter of the high-pressure cylinder will be 16.5 inches.

Let x = mean receiver pressure in pounds per square inch absolute.

$$155 - x = 4(x - 2)$$

$$\therefore x = 32.6 \text{ pounds per square inch.}$$

If n is the number of expansions in the low-pressure cylinder,

$$32.6 \times 1 = \frac{155}{1.2} \times n$$

$$n = 2.5$$

$$\therefore \text{cut-off in low-pressure is } \frac{1}{2.5} \text{ or } 0.4 \text{ of the stroke}$$

The mean effective pressure in the high-pressure cylinder will be—

$$0.82 \left\{ \frac{155}{3} (1 + \log_e 3) - 32.6 \right\}$$

$$= 0.82 \left\{ \frac{155}{3} \times 2.097 - 32.6 \right\}$$

$$= 0.82 \times 75.7$$

$$= 62 \text{ pounds per square inch.}$$

The mean effective pressure in the low-pressure cylinder will be—

$$0.82 \left\{ \frac{32.6}{2.5} (1 + \log_e 2.5) - 4 \right\}$$

$$= 0.82 \left\{ \frac{32.6}{2.5} \times 1.915 \right\}$$

$$= 0.82 \times 21$$

$$= 17.3 \text{ pounds per square inch}$$

Hence,

$$\frac{\text{work done in high-pressure cylinder}}{\text{work done in low-pressure cylinder}} = \frac{62}{4 \times 17.3} = \frac{1}{1.11}$$

EXAMPLE 2.—Estimate the diameters of the cylinders required for a quadruple expansion marine engine to develop 12,000 I.H.P. with a piston speed of 960 feet per minute. Pressure in steam chest 210 pounds per square inch gauge, number of expansions 14. Assume a ratio of low-pressure to high-pressure of 9, and a diagram factor 0.65. Find also the point of cut-off in the high-pressure cylinder.

Assuming a vacuum of 26 inches as in Example 1, *i.e.* a back-pressure

of 2 pounds per square inch absolute, the mean effective pressure referred to the low-pressure cylinder will be

$$\begin{aligned} p_m &= 0.65 \left\{ \frac{22.5}{14} (1 + \log_e 14) - 2 \right\} \\ &= 0.65 \left\{ \frac{22.5}{14} \times 3.639 - 2 \right\} \\ &= 0.65 \{ 58.5 - 2 \} \\ &= 0.65 \times 56.5 \\ &= 36.7 \text{ pounds per square inch} \end{aligned}$$

Hence, if A be the area of the low-pressure cylinder,

$$A \times 36.7 \times 960 = 12,000 \times 33,000$$

$$\begin{aligned} A &= \frac{12,000 \times 33,000}{36.7 \times 960} \\ &= 11,240 \text{ square inches.} \end{aligned}$$

$$\therefore d = \sqrt{\frac{11,240}{0.7854}} = 119.6 \text{ inches}$$

and diameter of high-pressure cylinder

$$= \frac{119.6}{3} = 39.5 \text{ inches}$$

Taking a ratio of cylinder volumes of

$$1 : 2.1 : 4.4 : 9$$

Diameter of 1st intermediate cylinder = $39.5 \times \sqrt{2.1} = 58$ inches.

„ 2nd „ „ = $39.5 \times \sqrt{4.4} = 83$ „

The cut-off in the high-pressure cylinder will be—

$$\frac{\text{ratio of low-pressure to high-pressure}}{\text{total number of expansions}} = \frac{9}{14} \text{ of the stroke}$$

89. The combination of Indicator Diagrams from a Compound Engine.—The indicator diagrams of a large horizontal compound engine developing 1415 I.H.P. are shown in Figs. 74 and 75. In order to combine these diagrams an average indicator diagram must be first constructed for each cylinder. The average diagram shown in Fig. 76 represents the mean diagram for both sides of the high-pressure piston; similarly Fig. 77 represents the mean diagram for both sides of the low-pressure piston. The saturation curves SS and $S'S'$ are then drawn one on each diagram by the method already explained in Art. 70.

Next set off any convenient distance AB , Fig. 78 (say 10 inches), to represent the piston displacement of the low-pressure piston (*i.e.* area of cylinder \times stroke), and oA to represent to the same scale the clearance volume; then choosing a convenient scale of pressures re-plot the mean diagram from the low-pressure cylinder together with its saturation curve $S'S'$, all volumes being plotted from the ordinate through point o . Next, to the same scale of volumes, set off CD to represent the clearance volume of the high-pressure cylinder, and DE the stroke volume of that cylinder; then re-plot the mean diagram from the high-pressure cylinder together with its saturation curve SS as shown in Fig. 78.

In the combined diagram drawn in Fig. 78 the saturation curves SS and $S'S'$ do not form one continuous curve. This is because the total

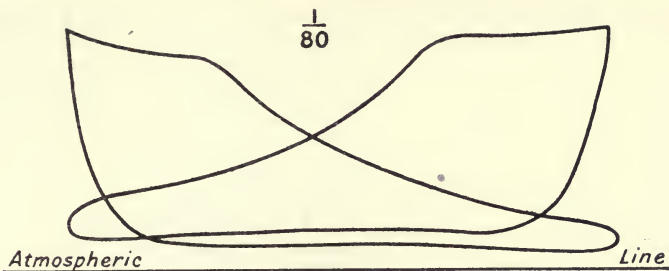

FIG. 74.

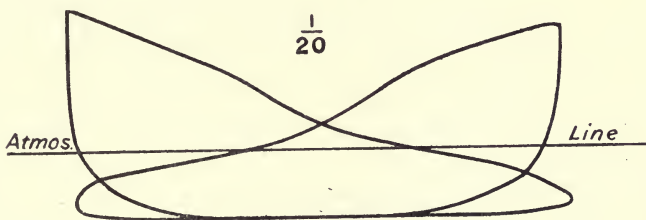

FIG. 75.

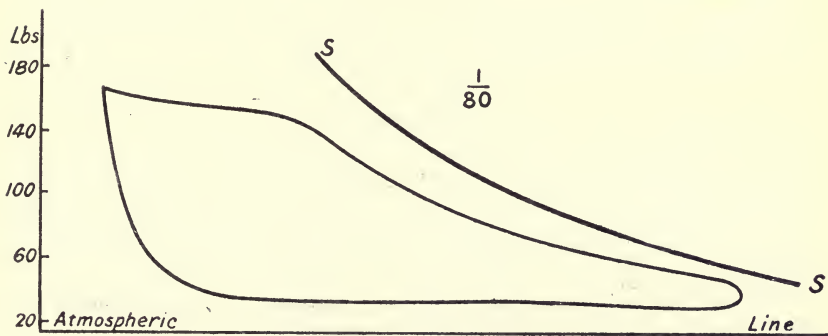

FIG. 76.

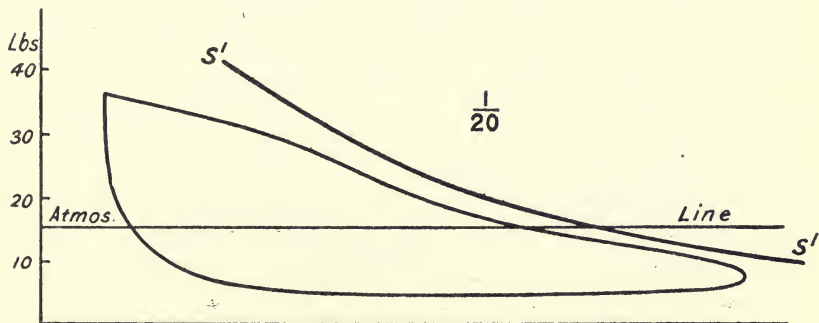

FIG. 77.

weight of steam present in the high-pressure cylinder during expansion is not the same as that in the low-pressure cylinder, the difference being due

to unequal weights of cushion steam in the two cylinders. A single saturation curve can only be drawn on the combined diagram when the same weight of cushion steam is present in each cylinder. As a rule the weight of cushion steam is less in the low-pressure than in the high-pressure cylinder, and this causes the saturation curve of the low-pressure to fall inside that of the high-pressure cylinder, as is shown in Fig. 78.

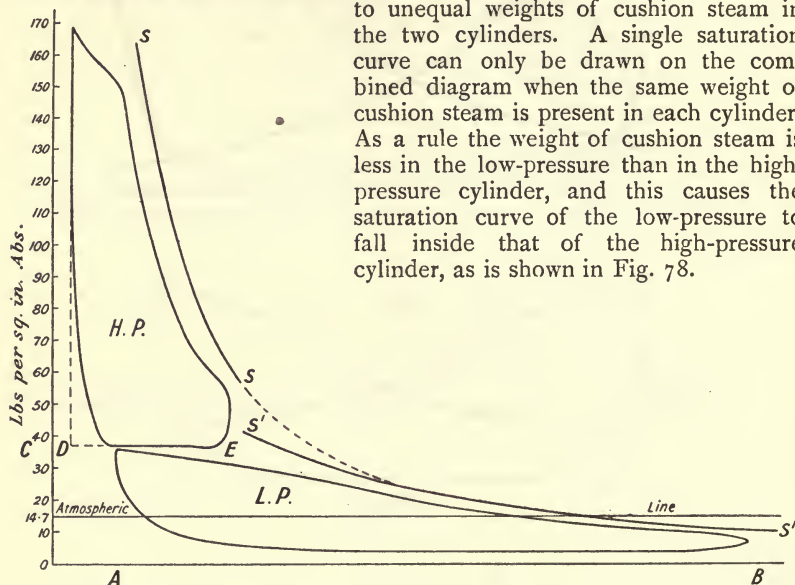

FIG. 78.

EXAMPLES VI

1. In a two-cylinder compound engine, the admission pressure to the high-pressure cylinder is 80 pounds per square inch absolute, cut-off 0.5 stroke. The release pressure in the low-pressure cylinder is 8 pounds per square inch absolute and the condenser pressure 2 pounds absolute. Assuming hyperbolic expansion and equal initial loads on the pistons, estimate the ratio of cylinder volumes, the mean pressure in the receiver, the point of cut-off in the low-pressure cylinder, and the ratio of the work done in the two cylinders.

2. Solve Question 1 if, instead of hyperbolic expansion, the law of expansion is $pv^{1.15} = \text{const.}$

3. Determine the cylinder diameters of a horizontal compound steam engine to develop 500 indicated horse-power under the following conditions: Pressure in steam chest 140 pounds per square inch absolute, vacuum 26 inches, number of expansions 10, diagram factor 0.80, piston speed 600 feet per minute, cut-off in high-pressure cylinder 0.35 stroke. Determine also the point of cut-off in the low-pressure cylinder and compare the work done in the two cylinders when the initial loads are equal.

4. In a two-cylinder compound engine the ratio of cylinder volumes is 5 and the total number of expansions is 10. The initial steam pressure is 100 pounds per square inch absolute and the back pressure 4 pounds per square inch absolute. Assuming continuous hyperbolic expansion and equal distribution of work between the two cylinders, compare the initial loads on the pistons.

5. A three-cylinder triple expansion engine is required to develop 5000 indicated horse-power at 90 revolutions per minute under the following conditions: Pressure in high-pressure steam chest 200 pounds per square inch absolute, cut-off in high-pressure cylinder 0.7 stroke, average piston speed 720 feet per minute, vacuum 28 inches. Using a cylinder ratio of 1 : 3 : 7.5 and a diagram factor 0.63, determine the dimensions of the cylinders.

6. If the initial loads on the pistons are equal estimate the mean receiver pressures for the engine in Question 5.

CHAPTER VII

MECHANICAL REFRIGERATION

90. Types of Mechanical Refrigerating Machines.—The function of a refrigerating machine is to produce and maintain a low temperature. This is done by employing some substance which is capable of absorbing heat, and by a suitable arrangement rendering it possible to continue withdrawing heat from the body to be kept cool as fast as it flows in; the heat which is taken from the cold body is then transferred to another body which is at a higher temperature. This process requires external assistance in the shape of expenditure of heat in the form of mechanical work, since by the second law of thermodynamics it is impossible for a self-acting machine to convey heat from one body to another at a higher temperature (see Art. 25).

Mechanical refrigerating machines may be divided into two classes, namely, (1) those which use *air* as the working substance, and (2) the compression type which employs a *vapour* which in the saturated state exhibits a high pressure at low temperatures.

Cold Air Machines.—In machines of this type, air is compressed to about 50 pounds per square inch and is then passed through a cooler the tubes of which are surrounded by water. In passing through the cooler the heat of compression is removed, after which the air is then passed through an interchanger. This interchanger consists essentially of a series of tubes surrounded by the cold air returning from the cold chamber, and in it the compressed air is further cooled, and any moisture it may contain is deposited as snow. From the interchanger the chilled compressed air passes to an expansion cylinder in which it expands, doing work and helping to drive the machine. The air is still further cooled by the expansion, after which it is exhausted and led away to the cold room.

Vapour Compression Machines.—The vapours used in modern machines of this type are ammonia, carbon-dioxide and occasionally sulphur-dioxide. Wet vapour is drawn into the compressor cylinder and after being compressed, is cooled and condensed, after which it expands (in practice through an expansion valve without doing useful work) to a low temperature and then passes on through a series of pipes immersed in brine. The brine is thereby cooled to a low temperature and is itself used for refrigerating purposes. This type of machine is the one most frequently adopted in practice.

91. Coefficient of Performance.—From what has been said in the previous Art., it is evident that a refrigerating machine is simply a *heat pump* which pumps up heat from a low to a higher temperature and has to be driven by mechanical means. The most economical machine

will be the one which extracts the greatest amount of heat from the cold body for a given expenditure of mechanical work.

The ratio

$$\frac{\text{heat extracted}}{\text{work expended}}$$

is known as the *coefficient of performance*, both quantities being reckoned in the same units.

It was shown in Art. 24 that the ideal heat engine works on a reversible cycle, taking in heat at a temperature T_1 , and rejecting heat at a lower temperature T_2 . If H_1 be the amount of heat taken in at temperature T_1 and H_2 the amount rejected at temperature T_2 , then the work done is $H_1 - H_2$ and the efficiency is

$$\frac{H_1 - H_2}{H_1} \quad \text{or} \quad \frac{T_1 - T_2}{T_1}$$

If now, such an engine be reversed, it would take H_2 units of heat from the cold body at temperature T_2 and $H_1 - H_2$ units of heat being supplied to drive the machine, H_1 units would be delivered from the machine at the higher temperature T_1 . The coefficient of performance would therefore be

$$\frac{\text{heat extracted}}{\text{work expended}} = \frac{H_2}{H_1 - H_2}$$

92. The Cold Air Machine.—Consider an engine working on the ideal Carnot cycle reversed. Starting at point c the cycle is in a clockwise

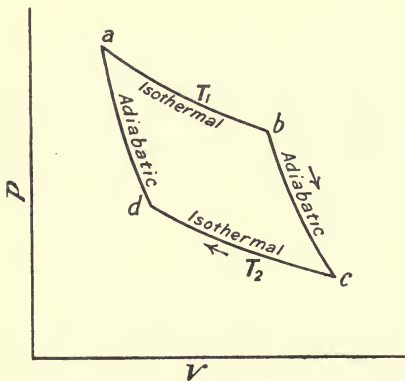

FIG. 79.

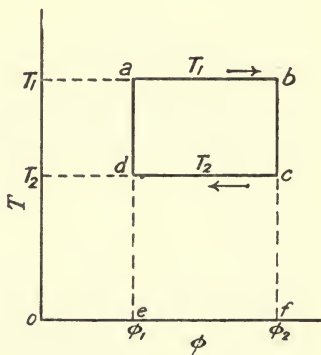

FIG. 80.

direction $cdab$ (Figs. 79 and 80). The engine will take in a quantity of heat H_2 at temperature T_2 and will reject a larger quantity H_1 at temperature T_1 , the work required to drive the machine being represented by the area $cdab$; in fact, the reversed perfect engine will act like a heat pump, withdrawing heat at a temperature T_2 and delivering it at a higher temperature T_1 , the coefficient of performance is—

$$\frac{H_2}{H_1 - H_2}$$

or referring to Fig 80

$$\begin{aligned} & \frac{\text{area } cdef}{\text{area } abfe - \text{area } dcef} \\ &= \frac{T_2(\phi_2 - \phi_1)}{T_1(\phi_2 - \phi_1) - T_2(\phi_2 - \phi_1)} \\ &= \frac{T_2}{T_1 - T_2} \dots \dots \dots (1) \end{aligned}$$

From (1) we see that the smaller the range of temperature ($T_1 - T_2$) the greater will be the co-efficient of performance and the greater the amount of refrigeration for a given expenditure of mechanical work. The

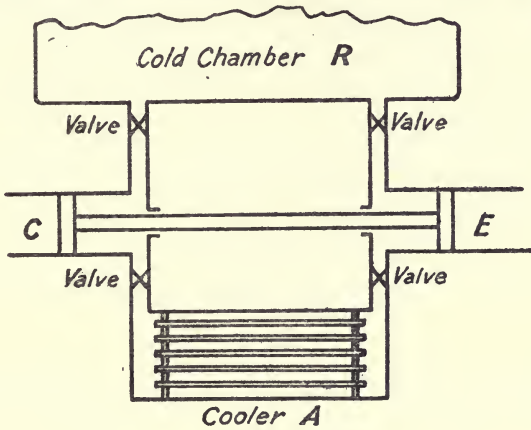

FIG. 81.

above expression only refers to the ideal reversed engine ; no refrigerating machine used in practice works on this cycle, but the commonest cold air machine in use works on the cycle of the reversed Joule engine.

93. The Reversed Joule Engine or the Bell-Coleman Refrigerating Machine.—

The most important development of the Joule hot air engine, described in Art. 29, has been in its reversed form, which has been developed as the Bell-Coleman refrigerating machine. A diagrammatic arrangement of the machine is shown in Fig. 81, whilst Fig. 82 represents the indicator diagram. The cycle is as follows :—

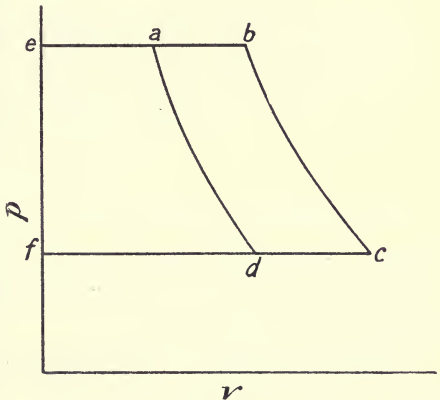

FIG. 82.

(1) The pump cylinder C takes in air from the cold chamber R at the lower temperature T_2 during its suction stroke fc .

(2) During the first portion of the return stroke the air is compressed

adiabatically up to the pressure existing in the cooler A, the temperature rising above that in A. This portion of the cycle is shown by *cb* (Fig. 82).

(3) The pump C then delivers air into A by completing its stroke from *b* to *e*; the temperature falls to that of A and the air rejects to A a quantity of heat H_1 such that

$$H_1 = C_p(T_b - T_a)$$

where T_b and T_a denote the temperatures at *b* and *a* respectively.

While these operations take place in the compressor cylinder C the following take place in the expansion cylinder E:—

During (1) and (2), E takes in an equal quantity of air from A at temperature T_a and expands it adiabatically down to the pressure in R as shown by *ea* and *ad* respectively (Fig. 82). At the end of expansion the temperature T_d is lower than that of the cold chamber R.

During (3). After expansion in E the chilled air is discharged into R during the return stroke *df*.

The work done on the air per cycle in the compressor cylinder is represented by the area *fcbe*, and the work done by the air in the expansion cylinder is represented by the area *eadf*, hence the net amount of work expended in driving the machine is given by

$$\text{area } fcbe - \text{area } eadf = \text{area } dcba$$

The net amount of heat extracted from the cold chamber per pound of air is

$$H_2 = C_p(T_c - T_d)$$

and since the ratio of expansion in E is the same as the ratio of compression in C

$$\frac{T_a}{T_d} = \frac{T_b}{T_c} \dots \dots \dots (1)$$

hence the coefficient of performance is

$$\begin{aligned} \frac{\text{heat extracted}}{\text{work expended}} &= \frac{H_2}{H_1 - H_2} \\ &= \frac{C_p(T_c - T_d)}{C_p(T_b - T_a) - C_p(T_c - T_d)} \\ &= \frac{T_c - T_d}{(T_b - T_a) - (T_c - T_d)} \\ &= \frac{T_d}{T_a - T_d} \text{ by (1) above} \dots \dots (2) \end{aligned}$$

This expression is less than the $\frac{T_2}{T_1 - T_2}$ of equation (1), Art. 92, for the same reason that Joule's engine is less efficient than Carnot's, *i.e.* all the heat is not taken in at the temperature T_2 and all is not rejected at the temperature T_1 ; in other words, $T_a - T_d$ is greater than the difference of temperature $T_1 - T_2$ of Art. 92.

The actual coefficient of performance obtained by this machine is very much lower than that of a vapour compression machine and varies from $\frac{1}{2}$ to $\frac{3}{4}$, this low value being due to

(1) The necessity of working with a wide range of temperature ($T_a - T_d$) since air is a poor conductor and absorber of heat.

(2) The large amount of air friction in the cylinders, particularly with large machines.

A difficulty experienced with this type of machine was the presence of moisture in the air coming from the cold chamber. At the end of expansion this moisture was deposited as snow which had a tendency to choke up the valves. Mr. Lightfoot got over this difficulty by employing compound expansion. In the first expansion cylinder the temperature was reduced to about 35° F. and the moisture deposited and then drained away. The most usual method, however, is to employ an interchanger as mentioned in Art. 90.¹

94. Reversed Heat Engine as a Warming Machine.—A machine of the Bell-Coleman type may be used for this purpose, as was first pointed out by Lord Kelvin in 1852.² The machine would take in air from the atmosphere, expand it down to a lower temperature and pressure and then allow its temperature to rise again by contact with the external air, after which the air would be compressed back again to atmospheric pressure, and its temperature thereby raised preparatory to being delivered into the room to be warmed.

Let H_2 = heat taken from the atmosphere at temperature T_2 ,
 H_1 = heat delivered to the room at temperature T_1 ,
 W = work expended in heat units.

$$\text{Then} \quad \frac{H_1}{W} = \frac{H_1}{H_1 - H_2} = \frac{T_1}{T_1 - T_2} \dots \dots \dots (1)$$

When the range of temperature $T_1 - T_2$ is small, H_1 may be many times greater than W , *i.e.* a large amount of heat may be raised through a small range of temperature with little expenditure of mechanical work.

EXAMPLE I.—If the compression pressure of a reversed Joule heat engine be 45 pounds per square inch gauge and the suction pressure 15 pounds per square inch absolute, find the lowest temperature produced in the engine, the air being cooled at the highest temperature by circulating water at the temperature of the atmosphere, which is 60° F.

The p v diagram is shown in Fig. 82.

$T_a = 460 + 60 = 520^{\circ}$ absolute, and T_d is the lowest temperature.

$$\text{Now} \quad \frac{T_a}{T_d} = \left(\frac{p_a}{p_d} \right)^{\frac{\gamma-1}{\gamma}} \text{ by (6), Art. 11}$$

$$= \left(\frac{45 + 15}{15} \right)^{\frac{1.4-1}{1.4}}$$

$$= 4^{\frac{2}{7}}$$

$$\therefore T_d = \frac{520}{4^{\frac{2}{7}}}$$

$$T_d = 350^{\circ} \text{ absolute or } 350 - 460 = -110^{\circ} \text{ F.}$$

¹ For details of this and other types of refrigerating machines, see "The Mechanical Production of Cold," by Sir J. Ewing, Cambridge University Press.

² *Proc. Phil. Soc. of Glasgow*, vol. iii. p. 269, or *Collected Papers*, vol. i. p. 515.

EXAMPLE 2.—Find the least horse-power of a perfect reversed heat engine that will make 900 lbs. of ice per hour at 27° F. from water at 70° F. Take the latent heat of ice as 142 B.Th.U. per pound and the specific heat as 0.5.

$$\text{Coefficient of performance} = \frac{T_2}{T_1 - T_2} = \frac{460 + 27}{70 - 27} = \frac{487}{43} = 11.33.$$

Heat extracted from 1 pound of water at 70° F. to produce 1 pound of ice at 27° F. will be

$$\begin{aligned} & (70 - 32) + 142 + 0.5(32 - 27) \\ & = 38 + 142 + 2.5 = 182.5 \text{ B.Th.U.} \end{aligned}$$

Hence the least horse-power will be

$$\frac{182.5 \times 900}{2545 \times 11.33} = 5.7.$$

EXAMPLE 3.—An oil engine uses Russolene of calorific value 20,000 B.Th.U. per pound. If it drives a reversed heat engine which takes in air at 40° F. and delivers it at 55° F., how much heat will be given to the air per brake horse-power hour if the reversed heat engine works at 80 per cent. of the ideal performance?

From (1), Art. 94

$$H_1 = W \cdot \frac{T_1}{T_1 - T_2} \times \frac{80}{100}$$

Now

$$W = 1 \text{ B.H.P. hour} = 2545 \text{ B.Th.U.}$$

$$\begin{aligned} \therefore H_1 &= 2545 \times \frac{460 + 55}{55 - 40} \times 0.8 \\ &= 69,900 \text{ B.Th.U.} \end{aligned}$$

A modern oil engine would use, say, 0.5 pound of oil per B.H.P. hour containing about 10,000 B.Th.U. When this oil is used to drive an oil engine which in turn drives a reversed heat engine as above, 69,900 B.Th.U. are given to the air, whilst if it were burned directly to warm the air, only 10,000 B.Th.U. would be available, *i.e.* about one-seventh as much. This does not, of course, mean that 69,900 — 10,000 or 59,900 B.Th.U. are created, but that the horse-power hour (2545 B.Th.U.) is converted into heat in the reversed engine and the remaining 69,900 — 2545 or 67,355 B.Th.U. are merely raised in temperature.

95. The Vapour Compression Machine.—This type of refrigerating machine is shown diagrammatically in Fig. 83 and the indicator diagram is shown in Fig. 84. Starting with volatile liquid in the refrigerator R the cycle is as follows:—

(1) The valve Q is opened and the refrigerant drawn into the cylinder C as a wet vapour at temperature T_2 . This portion of the cycle is represented by *dc* in Fig. 84.

(2) The vapour is compressed adiabatically to temperature T_1 along *cb*. Some of the heat of compression is absorbed in evaporating the liquid and at *b* the vapour should be just dry and saturated.

(3) The vapour is next discharged through the valve U into the condenser A at constant pressure and at constant temperature T_1 . The

vapour is cooled and condensed in A by cooling water and gives up its latent heat. This portion of the cycle is represented by *ba*.

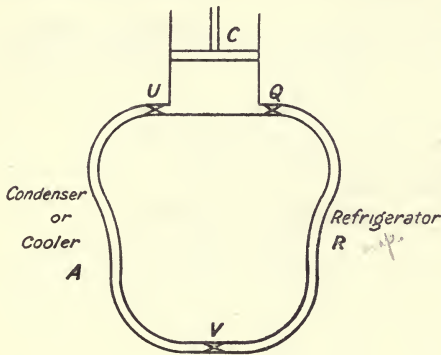

FIG. 83.

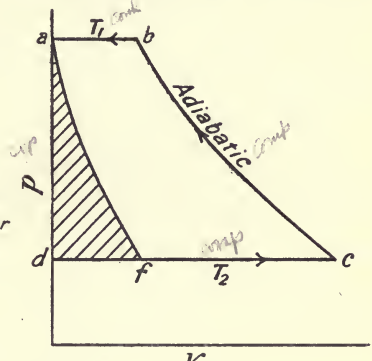

FIG. 84.

(4) In all machines used in practice, the liquid is then expanded freely through the reducing valve V back to its original state in R as represented by *ad* (Fig. 84). It might have been expanded adiabatically in a motor cylinder—and thus help to drive the machine—along *af*, and by so doing save an amount of work represented by the shaded area *afd*.

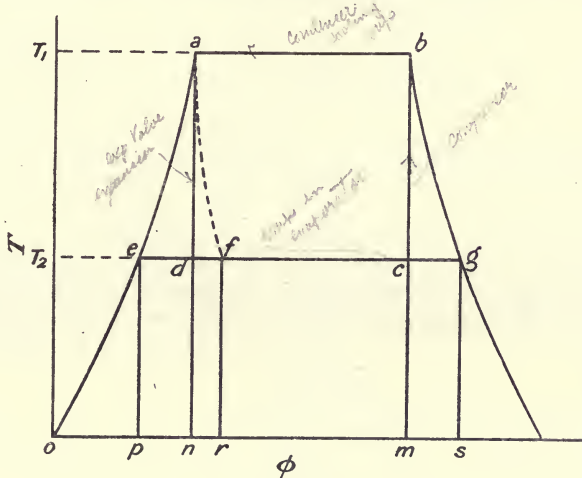

FIG. 85.

The theory of this type of refrigerating machine is more conveniently explained by reference to the temperature-entropy diagram shown in Fig. 85. The adiabatic compression of the wet vapour is shown by *cb*, then follows condensation at temperature T_1 along *ba*; *ae* represents the cooling of the liquid to T_2 in the cooler and *ec* its evaporation in the refrigerator. It is evident that when the expansion valve is used, the cycle is for all practical purposes the Rankine cycle reversed. (Cp. *dcb*

Fig. 84 and *ecba* Fig. 85 with Figs. 30 and 33.) We will now consider the theory of the cycle with both wet and dry compression, with both an expansion valve and an expansion cylinder.

96. Vapour Compression Machine working without Superheating and with an Expansion Cylinder.—Consider the temperature-entropy diagram shown in Fig. 85. The cycle is—

- (1) *dc*, pump suction the vapour taking up its latent heat at T_2 .
- (2) *cb*, adiabatic compression until just dry and saturated at T_1 .
- (3) *ba*, isothermal compression at T_1 the vapour being condensed and giving up its latent heat to the cooling water.
- (4) *ad*, adiabatic expansion doing useful work in a motor cylinder and helping to drive the machine.

The heat extracted from the refrigerant is represented by the area *dcmn*, and the work done in driving the machine by the area *dcba*, hence the coefficient of performance will be—

$$\frac{\text{heat extracted}}{\text{work done}} = \frac{\text{area } dcmn}{\text{area } dcba}$$

This may be put in algebraic form as follows:—

Let s denote the specific heat of the liquid and L_1 its latent heat of evaporation at T_1 , then

$$ed = s \log_e \frac{T_1}{T_2} \quad \text{and} \quad ab = \frac{L_1}{T_1}$$

hence,
$$\text{area } dcmn = \frac{L_1}{T_1} \times T_2'$$

and
$$\text{area } dcba = \frac{L_1}{T_1} (T_1 - T_2)$$

$$\therefore \text{coefficient of performance} = \frac{\frac{L_1 T_2}{T_1}}{\frac{L_1}{T_1} (T_1 - T_2)} = \frac{T_2}{T_1 - T_2} \quad \dots (1)$$

Note that this is the same expression as (1), Art. 92.

Case when the Vapour is Wet at the end of Compression.—In this case compression starts at point *k* (Fig. 86) and finishes at some point *h*, the dryness fraction at the end of compression being—

$$x_1 = \frac{ah}{ab}$$

$$\begin{aligned} \text{Heat extracted per pound} &= \text{area } dklm \\ &= \frac{x_1 L_1}{T_1} \times T_2 \end{aligned}$$

$$\begin{aligned} \text{work done} &= \text{area } dkha \\ &= \frac{x_1 L_1}{T_1} (T_1 - T_2) \end{aligned}$$

$$\text{and coefficient of performance} = \frac{\frac{x_1 L_1}{T_1} \times T_2}{\frac{x_1 L_1}{T_1} (T_1 - T_2)} = \frac{T_2}{T_1 - T_2} \text{ as before}$$

In this case, although the coefficient of performance is the same as

before, there is less refrigeration per pound of the liquid, and therefore more of the liquid will be required for the same amount of refrigeration.

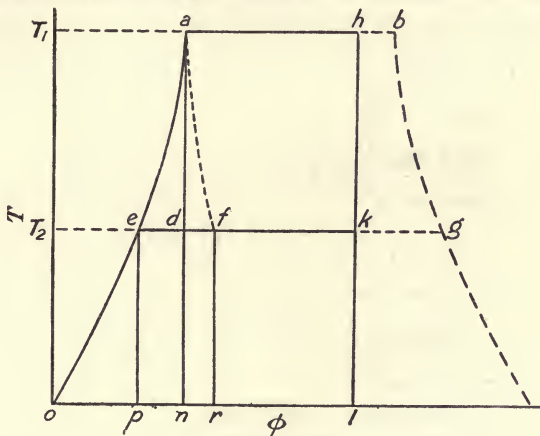

FIG. 86.

97. Vapour Compression Machine working without Superheating and with an Expansion Valve.—This is the usual case in practice, and instead of adiabatic expansion in a motor cylinder we have free, unresisted expansion through the expansion valve, the expansion terminating at some point *f* (Fig. 85). We have here for all practical purposes the Rankine cycle reversed, the indicator diagram being as shown in Fig. 84, namely *dcba*.

Assuming no gain or loss of heat when passing through the expansion valve, the heat contained by 1 pound of the stuff will be the same before and after throttling (*cp.* Arts. 38 and 47). The heat before expansion is represented by the area *eanp* (Fig. 85), and that after expansion by the area *efrp*. Hence these two areas must be equal, or since the area *ednp* is common, the area *ead* must equal the area *dfrn*.

The net amount of refrigeration per pound, *i.e.* the heat extracted, will be represented by the area *fcmr*, and the work done by the area *eabc*, hence the coefficient of performance will be—

$$\frac{\text{area } fcmr}{\text{area } eabc}$$

Suppose that by the use of an expansion *cylinder*, *w* represents the amount of work done per pound in the cylinder. This is represented by the area *ead* in Fig. 85 and *afd* in Fig. 84; and since area *dfrn* (Fig. 85) is equal to area *ead*, it follows that the net amount of refrigeration is less than the area *dcmn* by an amount *w*. Hence if *H* denotes the amount of refrigeration per pound and *W* the work done when an expansion cylinder is employed, the coefficient of performance when using an expansion valve will be—

$$\frac{\text{heat extracted}}{\text{work done}} = \frac{H - w}{W + w} \dots \dots \dots (1)$$

which is obviously less than $\frac{H}{W}$.

Using the same notation as in Art. 96, this result may be expressed algebraically as follows:—

$$\text{Area } eanp = \text{area } efrp = s(T_1 - T_2)$$

$$\therefore ef = \frac{s(T_1 - T_2)}{T_2}$$

$$\begin{aligned} \text{Now } \quad ec &= ed + dc \\ &= s \log_{\epsilon} \frac{T_1}{T_2} + \frac{L_1}{T_1} \end{aligned}$$

$$\begin{aligned} \therefore fc &= ec - ef \\ &= s \log_{\epsilon} \frac{T_1}{T_2} + \frac{L_1}{T_1} - \frac{s(T_1 - T_2)}{T_2} \end{aligned}$$

$$\begin{aligned} \text{Heat extracted} &= \text{area } fcmr = T_2 \times fc \\ &= sT_2 \log_{\epsilon} \frac{T_1}{T_2} + \frac{L_1}{T_1} \cdot T_2 - s(T_1 - T_2) \quad \dots (2) \end{aligned}$$

$$\begin{aligned} \text{Also, work done} &= \text{area } eabc \\ &= \text{area } peabm - \text{area } ecnp \\ &= \text{area } pean + \text{area } abmn - \text{area } edpn - \text{area } dcmm \\ &= s(T_1 - T_2) + \frac{L_1}{T_1} \times T_1 - T_2 \cdot s \log_{\epsilon} \frac{T_1}{T_2} - \frac{L_1}{T_1} \times T_2 \\ &= (T_1 - T_2) \left(s + \frac{L_1}{T_1} \right) - T_2 \cdot s \log_{\epsilon} \frac{T_1}{T_2} \quad \dots (3) \end{aligned}$$

(This is the same as the work done on the Rankine cycle, *cp.* (7), Art. 57, p. 77.)

$$\begin{aligned} \text{Coefficient of performance} &= \frac{\text{heat extracted}}{\text{work done}} \\ &= \frac{sT_2 \log_{\epsilon} \frac{T_1}{T_2} + \frac{L_1}{T_1} \cdot T_2 - s(T_1 - T_2)}{(T_1 - T_2) \left(s + \frac{L_1}{T_1} \right) - T_2 \cdot s \log_{\epsilon} \frac{T_1}{T_2}} \quad (4) \end{aligned}$$

Case when the Vapour is Wet at the end of Compression.—Here the compression commences at point *k* (Fig. 86) and finishes at some point *h*, the dryness fraction at the end of compression being—

$$x_1 = \frac{ah}{ab}$$

$$\begin{aligned} \text{Heat extracted} &= \text{area } fklr \\ &= sT_2 \log_{\epsilon} \frac{T_1}{T_2} + \frac{x_1 L_1}{T_1} \cdot T_2 - s(T_1 - T_2) \quad (5) \end{aligned}$$

$$\begin{aligned} \text{work done} &= \text{area } eahk \\ &= (T_1 - T_2) \left(s + \frac{x_1 L_1}{T_1} \right) - T_2 \cdot s \log_{\epsilon} \frac{T_1}{T_2} \quad (6) \end{aligned}$$

$$\begin{aligned} \text{Coefficient of performance} &= \frac{s \cdot T_2 \log_{\epsilon} \frac{T_1}{T_2} + \frac{x_1 L_1}{T_1} \cdot T_2 - s(T_1 - T_2)}{(T_1 - T_2) \left(s + \frac{x_1 L_1}{T_1} \right) - T_2 \cdot s \log_{\epsilon} \frac{T_1}{T_2}} \quad (7) \end{aligned}$$

98. Vapour Compression Machine working with Superheating and with Expansion Cylinder.—Consider the case in which the compressor draws in dry saturated vapour from the refrigerator. The temperature-entropy diagram is shown in Fig. 87. The compression now commences at point *g* and ends at some point *h*, on the superheat

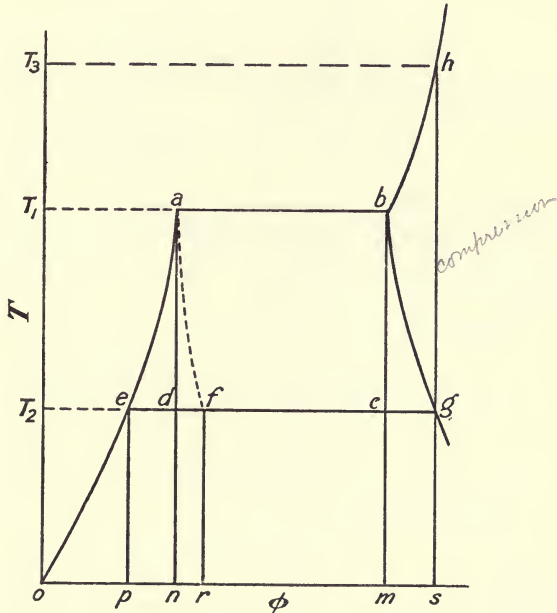

FIG. 87.

curve corresponding to the pressure at saturation temperature T_1 , where the temperature is, say, T_3 .

$$\begin{aligned} \text{Heat extracted} &= \text{area } dgsn \\ &= \text{area } dcmn + \text{area } cgsn \\ &= \frac{L_1}{T_1} \cdot T_2 + T_2 \cdot C_p \log_e \frac{T_3}{T_1} \dots \dots \dots (1) \end{aligned}$$

where C_p is the specific heat of the vapour at constant pressure (assumed constant).

$$\begin{aligned} \text{Work done} &= \text{area } dabhg \\ &= \text{area } dabc + \text{area } bhsn - \text{area } cgsn \\ &= \frac{L_1}{T_1} (T_1 - T_2) + C_p (T_3 - T_1) - T_2 \cdot C_p \log_e \frac{T_3}{T_1} \dots \dots (2) \end{aligned}$$

$$\text{Coefficient of performance} = \frac{T_2 \left(\frac{L_1}{T_1} + C_p \cdot \log_e \frac{T_3}{T_1} \right)}{\frac{L_1}{T_1} (T_1 - T_2) + C_p (T_3 - T_1 - T_2 \log_e \frac{T_3}{T_1})} \dots (3)$$

To calculate T_3 we may proceed as follows :—

In passing along the superheat curve from b to h , the gain of entropy is—

$$eg = C_p \log_{\epsilon} \frac{T_3}{T_1} \dots \dots \dots (4)$$

also

$$\begin{aligned} eg &= eg - ec \\ &= \frac{L_2}{T_2} - s \log_{\epsilon} \frac{T_1}{T_2} - \frac{L_1}{T_1} \dots \dots \dots (5) \end{aligned}$$

Equating (4) and (5) we have

$$C_p \log_{\epsilon} \frac{T_3}{T_1} = \frac{L_2}{T_2} - s \log_{\epsilon} \frac{T_1}{T_2} - \frac{L_1}{T_1} \dots \dots \dots (6)$$

an equation from which T_3 may be calculated.

99. Vapour Compression Machine working with Superheating and with Expansion Valve.—The expansion now ends at some point f (Fig. 87) as in Art. 97.

Heat extracted = area $fgsr$

Now $eg = \frac{L_2}{T_2}$ and $ef = \frac{s(T_1 - T_2)}{T_2}$

hence

$$\begin{aligned} fg &= eg - ef \\ &= \frac{L_2}{T_2} - \frac{s(T_1 - T_2)}{T_2} \end{aligned}$$

hence

heat extracted = $fg \times T_2$
 $= L_2 - s(T_1 - T_2) \dots \dots \dots (1)$

Work done

= area $cabhg$

= area cad + area $dabhg$

$$= s(T_1 - T_2) - T_2 \cdot s \log_{\epsilon} \frac{T_1}{T_2} + \frac{L_1}{T_1}(T_1 - T_2) + C_p(T_3 - T_1) - T_2 \cdot C_p \log_{\epsilon} \frac{T_3}{T_1} \dots \dots \dots (2)$$

$$= (T_1 - T_2) \left(s + \frac{L_1}{T_1} \right) + C_p(T_3 - T_1) - T_2 \left(s \log_{\epsilon} \frac{T_1}{T_2} + C_p \log_{\epsilon} \frac{T_3}{T_1} \right) \dots \dots \dots (3)$$

(Cp. (1), Art. 58)

Coefficient of performance

$$= \frac{L_2 - s(T_1 - T_2)}{(T_1 - T_2) \left(s + \frac{L_1}{T_1} \right) + C_p(T_3 - T_1) - T_2 \left(s \log_{\epsilon} \frac{T_1}{T_2} + C_p \log_{\epsilon} \frac{T_3}{T_1} \right)} \dots \dots \dots (4)$$

EXAMPLE 1.—In an ammonia refrigerating machine the temperature in the refrigerator is 14° F., and after compression 86° F. In the cooler the vapour is condensed at 86° F. and then passes through an expansion valve into the refrigerator. Estimate the coefficient of performance when the vapour at the end of compression is, (a) just dry and saturated, (b) 90 per cent. dry. Take the latent heat of ammonia at 86° F. as 490.5 B.Th.U. per pound and the specific heat of the liquid as 1.12 .

(a) By (2), Art. 97

$$\text{heat extracted per pound} = sT_2 \log_{\epsilon} \frac{T_1}{T_2} + \frac{L_1}{T_1} \cdot T_2 - s(T_1 - T_2)$$

$$\text{here } T_1 = 86 + 460 = 546^{\circ} \text{ absolute}$$

$$T_2 = 14 + 460 = 474^{\circ} \text{ absolute}$$

$$L_1 = 490.5$$

$$\begin{aligned} \therefore \text{heat extracted} &= 1.12 \times 474 \times \log_{\epsilon} \frac{546}{474} + \frac{490.5 \times 474}{546} - 1.12(546 - 474) \\ &= 75.08 + 425.65 - 80.64 \\ &= 420.09 \text{ B.Th.U.} \end{aligned}$$

By (3), Art. 97

$$\begin{aligned} \text{work done} &= (T_1 - T_2) \left(s + \frac{L_1}{T_1} \right) - T_2 \cdot s \log_{\epsilon} \frac{T_1}{T_2} \\ &= (546 - 474) \left(1.12 + \frac{490.5}{546} \right) - 474 \times 1.12 \log_{\epsilon} \frac{546}{474} \\ &= 72 \times 2.02 - 75.08 \\ &= 70.36 \text{ B.Th.U.} \end{aligned}$$

$$\therefore \text{coefficient of performance} = \frac{420.09}{70.36} = 5.97$$

(b) By (5), Art. 97

$$\begin{aligned} \text{heat extracted} &= sT_2 \log_{\epsilon} \frac{T_1}{T_2} + \frac{x_1 L_1}{T_1} \cdot T_2 - s(T_1 - T_2) \\ &= 75.08 + 0.9 \times 425.65 - 80.64 \\ &= 377.52 \text{ B.Th.U.} \end{aligned}$$

By (6), Art. 97

$$\begin{aligned} \text{work done} &= (T_1 - T_2) \left(s + \frac{x_1 L_1}{T_1} \right) - T_2 \cdot s \log_{\epsilon} \frac{T_1}{T_2} \\ &= 72(1.12 + 0.81) - 75.08 \\ &= 63.88 \text{ B.Th.U.} \end{aligned}$$

$$\therefore \text{coefficient of performance} = \frac{377.52}{63.88} = 5.90$$

EXAMPLE 2.—Solve the problem of Example 1 when an expansion cylinder is used instead of an expansion valve.

(a) By Art. 96

$$\text{Heat abstracted} = \frac{L_1 T_2}{T_1} = \frac{490.5 \times 474}{546} = 425.65 \text{ B.Th.U.}$$

$$\text{Work done} = \frac{L_1}{T_1} (T_1 - T_2) = \frac{490.5 \times 72}{546} = 64.69 \text{ B.Th.U.}$$

$$\text{Coefficient of performance} = \frac{425.65}{64.69} = 6.58$$

$$(b) \text{Heat extracted} = 0.9 \times 425.65 = 383.08 \text{ B.Th.U.}$$

$$\text{work done} = 0.9 \times 64.69 = 58.22 \text{ B.Th.U.}$$

$$\text{coefficient of performance} = \frac{383.08}{58.22} = 6.58.$$

Note.—By Art. 96 the coefficient of performance in both cases is simply $\frac{T_2}{T_1 - T_2}$ and there is no necessity to work out separately the heat extracted and the work done in each case. It is done here in order to allow for comparison with the other cases (see p. 167).

EXAMPLE 3.—Consider the machine taken in Examples 1 and 2, but let the vapour be just dry and saturated when compression begins. Estimate the coefficient of performance. (Take $C_p = 0.508$ and $L_2 = 577.4$ B.Th.U. per pound.)

The temperature after compression (T_3) is given by (6), Art. 98.

$$\begin{aligned} C_p \log_e \frac{T_3}{T_1} &= \frac{L_2}{T_2} - s \log_e \frac{T_1}{T_2} - \frac{L_1}{T_1} \\ 0.508 \times \log_e \frac{T_3}{546} &= \frac{577.4}{474} - 1.12 \times \log_e \frac{546}{474} - \frac{490.5}{546} \\ 0.508 \times 2.303 \log_{10} \frac{T_3}{546} &= \frac{577.4}{474} - 1.12 \times 2.303 \log_{10} \frac{546}{474} - \frac{490.5}{546} \\ 1.17 \log_{10} \frac{T_3}{546} &= 1.218 - 0.158 - 0.898 \\ &= 0.162 \\ \therefore \log_{10} T_3 - \log_{10} 546 &= \frac{0.162}{1.17} = 0.1384 \\ \text{from which } T_3 &= 750.9^\circ \text{ absolute.} \end{aligned}$$

With expansion valve—

$$\begin{aligned} \text{heat extracted} &= L_2 - s(T_1 - T_2) \text{ (by (1), Art. 99)} \\ &= 577.4 - 1.12 \times 72 \\ &= 496.76 \text{ B.Th.U.} \end{aligned}$$

work done by (3), Art. 98—

$$\begin{aligned} &= (T_1 - T_2) \left(s + \frac{L_1}{T_1} \right) - T_2 \cdot s \log_e \frac{T_1}{T_2} + C_p (T_3 - T_1 - T_2 \log_e \frac{T_3}{T_1}) \\ &= 70.36 + 0.508 \left(750.9 - 546 - 474 \log_e \frac{750.9}{546} \right) \\ &= 70.36 + 27.33 \\ &= 97.69 \text{ B.Th.U.} \end{aligned}$$

$$\therefore \text{coefficient of performance} = \frac{496.76}{97.69} = 5.08$$

With expansion cylinder—

$$\begin{aligned} \text{heat extracted} &= \frac{L_1 T_2}{T_1} + T_2 \cdot C_p \log_e \frac{T_3}{T_1} \text{ (by (1), Art. 98)} \\ &= \frac{490.5 \times 474}{546} + 474 \times 0.508 \log_e \frac{750.9}{546} \\ &= 425.65 + 76.76 \\ &= 502.41 \text{ B.Th.U.} \end{aligned}$$

work done—

$$\begin{aligned}
 &= \frac{L_1}{T_1}(T_1 - T_2) + C_p(T_3 - T_1) - T_2 \cdot C_p \log_e \frac{T_3}{T_1} \\
 &\quad \text{(by (2), Art. 98)} \\
 &= \frac{490.5 \times 72}{546} + 0.508(780.9 - 546) - 474 \times 0.508 \log_e \frac{750.9}{546} \\
 &= 64.69 + 27.33 \\
 &= 92.02 \text{ B.Th.U.}
 \end{aligned}$$

∴ coefficient of performance = $\frac{502.41}{92.02} = 5.45$

For convenience in comparison the results obtained in the above examples are tabulated below.

	State at end of compression.	Heat abstracted B.Th.U. per pound.	Work done B.Th.U. per pound.	Coefficient of performance.
Expansion valve . .	Dry and saturated	420.09	70.36	5.97
„ „ . .	90 per cent. dry	377.52	63.88	5.90
„ „ . .	Superheated to 750.9° F.	496.76	97.69	5.08
Expansion cylinder .	Dry and saturated	425.65	64.69	6.58
„ „ .	90 per cent. dry	383.08	58.22	6.58
„ „ .	Superheated to 750.9° F.	502.41	92.02	5.45

It will be seen that the coefficient of performance is greatest when the refrigerating agent used is just dry and saturated at the end of compression. The effect of allowing superheating to take place during compression increases the amount of refrigeration at the expense of a greatly increased amount of work done in driving the compression, the result being a reduced coefficient of performance. The heat of compression also raises the temperature of the compressor walls, and on the entrance of the next charge of cold vapour, heat is absorbed by it and the vapour expands. The result is that a smaller charge is taken in and there is less refrigeration per cycle, although, as shown in the table, the refrigeration per pound is greater.

EXAMPLE 4.—An ammonia compression refrigerating machine has to do an amount of refrigeration equal to the production of 25 tons of ice per 24 hours from and at 32° F. If the temperature limits in the compressor are 75° F. and — 5° F., calculate the horse-power of the compressor on the assumption that the cycle is a perfect one.

The coefficient of performance of a perfect machine = $\frac{T_2}{T_1 - T_2}$
 $= \frac{455}{80} = 5.687$

Taking the latent heat of ice as 142 B.Th.U. per pound, we have—

$$\text{Heat to be extracted per minute} = \frac{25 \times 2240 \times 142}{24 \times 60} = 5560 \text{ B.Th.U.}$$

$$\text{Now} \quad \frac{H}{W} = 5.687$$

$$\therefore \text{work done per minute, } W = \frac{5560}{5.687} \times 778 \text{ foot-pounds}$$

$$\text{and horse-power} = \frac{5560 \times 778}{5.687 \times 33,000} = 22.4 \text{ H.P.}$$

Note.—An actual machine will have a coefficient of performance of from 60 to 70 per cent. of the ideal. Hence the B.H.P. of the engine driving the above compression would have to be about $\frac{22.4}{0.6} = 37$ B.H.P.

100. Choice of a Refrigerating Agent.—In deciding upon the liquid to use in a vapour compression machine the most important properties to be considered are, the specific volume of the vapour, the latent heat of evaporation, and the specific heat of the liquid. The ideal liquid will have a very high latent heat and a low specific heat, whilst the vapour will have a low specific volume at a moderately low pressure. None of the liquids in use possess all these properties, and in practice the number is restricted to one of three, viz. carbon dioxide (CO₂), ammonia (NH₃), and sulphur dioxide (SO₂).

The accompanying table shows a comparison between these three agents taken for a lower temperature limit of 5° F.¹

Agent.	Pressure, lbs. per sq. in. abs. at 5° F.	Latent heat, B.Th.U. per lb. at 5° F.	Specific vol. cu. ft. per lb. at 5° F.	Possible refrigeration per cubic foot,	Relative size of compression, a to L
	$\frac{p}{L}$	$\frac{L}{V}$	$\frac{V}{L}$	$\frac{L}{V}$	$\frac{V}{L}$
CO ₂	334	115.25	0.267	431.6 (best)	1 (best)
NH ₃	33.67	582.10 (best)	8.39	69.3	6.26
SO ₂	11.76	169.74	6.49	26.1	16.60

From the above table it is evident that SO₂ is inferior to both CO₂ and NH₃, and that the CO₂ machine is the smallest and has a much greater possible refrigeration per cubic foot of vapour. Further comparisons, however, are necessary. If the higher temperature limit be taken as 86°F. reference to tables will show that at this temperature the pressure of CO₂ vapour is 1040 pounds per square inch, of NH₃ 180 pounds per square inch, and of SO₂ 67 pounds per square inch; hence, although the CO₂ machine is the smallest, its compression pressure is very high (particularly in the tropics, where the maximum temperature may exceed 86° F.), and this necessitates greater attention to mechanical details. In the case of NH₃, the range of pressure (from 33.67 to 180) is moderate and more convenient for general use, but at the same time its use precludes the employment of brass and copper for any of the working parts of the machine;

¹ The values of p , L , and V are taken from the tables given in "Technical Thermodynamics," by Dr. Zeuner, A. Constable & Co.

fortunately, however, this agent has no action on iron. CO_2 , on the other hand, has no chemical action upon either iron, copper or brass.

As already mentioned in Art. 97, practically all vapour compression machines use an expansion valve *not* an expansion cylinder. The resulting loss of refrigeration consists in the amount of heat carried with the liquid into the refrigerator as it flows through the valve. This, as shown in Art. 98, is represented by the area *canp* of Fig. 85, being equal to $s(T_1 - T_2)$; the greater the specific heat of the liquid the greater will be this loss. The following table shows this loss for the three agents under discussion, the temperature limits being taken for this purpose as 86°F. and 14°F. :—

Agent.	Heat carried over in liquid ($h_1 - h_2$)	Latent heat at 86°F. L	Possible refrigeration, $L - (h_1 - h_2)$	Proportionate loss, $\frac{h_1 - h_2}{L}$
CO_2	54'45	110'65	56'20	0'49
NH_3	79'56	577'4	487'94	0'137
SO_2	23'23	168'18	145'95	0'138

From this table it will be seen that the proportionate loss in the case of CO_2 is very much greater than with the other two agents, and of the three substances ammonia is the best. It should also be pointed out that leakages are more easily detected in the case of NH_3 and SO_2 on account of their smell.

EXAMPLES VII

1. By means of a reversed perfect heat engine, ice at 32°F. is to be made from water at 67°F. , the temperature of the brine or freezing mixture being 12°F. How many pounds of ice at 32°F. can be made per I.H.P. hour? (Latent heat of ice 142 B.Th.U. per pound.)

2. If the compression pressure in a Bell-Coleman refrigerating machine is 60 pounds per square inch gauge and the suction pressure 15 pounds absolute, find the lowest temperature produced in the machine if the air after compression is cooled to 60°F. What is the coefficient of performance, and how much ice can be made from and at 32°F. per I.H.P. hour?

3. Find the least horse-power of a perfect reversed heat engine that will make 1200 pounds of ice per hour at 25°F. from water at 60°F. (Take specific heat of ice as 0'5 and latent heat 142 B.Th.U. per pound.)

4. In an ammonia refrigerating machine the temperature in the refrigerator is 15°F. and after compression 90°F. In the cooler the vapour is condensed at 90°F. and then passes through an expansion valve. Calculate the coefficient of performance when the vapour at the end of adiabatic compression is (a) just dry and saturated; (b) 85 per cent. dry. Take the specific heat of liquid ammonia as 1'1, and the latent heat of vaporisation as $566 - 0'8t^\circ \text{F.}$

5. Solve Problem 4 when an expansion cylinder is used instead of an expansion valve.

6. If in Problem 4 the ammonia is just dry and saturated at the beginning of compression, estimate the coefficient of performance (a) when an expansion valve is used, and (b) when an expansion cylinder is used. (Assume $C_p = 0'508$.)

7. A vapour compression machine has to produce 50 tons of ice per day of 24 hours at 28°F. from water at 50°F. If the temperature limits in the compressor are 80°F. and 10°F. , calculate the horse-power of the compressor on the assumption that the cycle is a perfect one.

8. The following are approximate expressions for the entropy of ammonia liquid and

dry saturated vapour : liquid, $0.00184(t - 32)$; vapour, $1.158 - 0.00192(t - 32)$, t being the temperature on the Fahrenheit scale : obtain corresponding expressions of the form $a + bt_c$, t_c being the temperature on the Centigrade scale. Draw the $\theta - \phi$ chart between temperatures of 14° F. and 77° F. (-10° C. and 25° C.). Find the coefficient of performance of a refrigerator working on a reversed Rankine cycle between these limits, the vapour being 5 per cent. wet at the end of compression. If the actual performance is 0.6 of the amount in the above ideal case, calculate the pounds of ice produced per horsepower hour from water at the freezing-point. Latent heat of ice, 144 B.Th.U. (80 C.H.U.). (L.U.)

CHAPTER VIII

FLOW OF STEAM THROUGH ORIFICES AND NOZZLES

101. Adiabatic Flow through an Orifice.—Assume that the orifice has well-rounded edges so that the least cross-sectional area of the jet of steam is the same as the area of the orifice, and further, that there is no frictional resistance offered to the flow. Let p_1 and p_2 denote the pressure on the two sides of the orifice, *i.e.* let the steam flow from rest, through the orifice from a vessel in which the pressure is maintained at p_1 into a vessel where the pressure is maintained at p_2 . Instead of the steam doing work on, say, an engine piston, it does work on itself in generating kinetic energy; the kinetic energy per pound of steam issuing from the orifice will, in heat units, be equal to the difference between the heat contents before and after expansion to the lower pressure p_2 .

Let V be the velocity of the steam jet in feet per second, then

$$\text{kinetic energy} = \frac{V^2}{2gJ} = h_1 + x_1L_1 - (h_2 + x_2L_2) \quad \dots (1)$$

where x_1 and x_2 are the initial and final dryness fractions respectively.

Now
$$x_2 = \frac{T_2}{L_2} \left(\frac{x_1L_1}{T_1} + \log_{\epsilon} \frac{T_1}{T_2} \right) \dots (3), \text{ Art. 46,}$$

and assuming the specific heat of water to be constant and equal to unity, we have—

$$\begin{aligned} \frac{V^2}{2gJ} &= h_1 - h_2 + x_1L_1 - x_2L_2 \\ &= T_1 - T_2 + x_1L_1 - L_2 \cdot \frac{T_2}{L_2} \left(\frac{x_1L_1}{T_1} + \log_{\epsilon} \frac{T_1}{T_2} \right) \\ &= (T_1 - T_2) \left(1 + \frac{x_1L_1}{T_1} \right) - T_2 \log_{\epsilon} \frac{T_1}{T_2} \quad \dots (2) \end{aligned}$$

hence the kinetic energy is the same as the work done on the Rankine cycle, and the velocity of the steam is—

$$V = \sqrt{2gJ \left\{ (T_1 - T_2) \left(1 + \frac{x_1L_1}{T_1} \right) - T_2 \log_{\epsilon} \frac{T_1}{T_2} \right\}} \quad \dots (3)$$

The velocity may also be expressed in terms of pressures, since approximately

$$\frac{V^2}{2g} = \frac{n}{n-1} (p_1v_1 - p_2v_2) \quad \dots (\text{see (6), Art. 53})$$

Now the expansion follows the law $p v^n = \text{constant}$, hence by Art. 12

$$\frac{V^2}{2g} = \frac{n}{n-1} \cdot p_1 v_1 \left\{ 1 - \left(\frac{p_2}{p_1} \right)^{\frac{n-1}{n}} \right\} \dots \dots \dots (4)$$

$$V = \sqrt{2g \cdot \frac{n}{n-1} \cdot p_1 v_1 \left\{ 1 - \left(\frac{p_2}{p_1} \right)^{\frac{n-1}{n}} \right\}} \dots \dots \dots (5)$$

In (5) p_1 and p_2 denote the initial and final pressures respectively in pounds per square foot, and v_1 the specific volume of the steam in cubic feet at pressure p_1 . If the steam be initially dry saturated the value of n for adiabatic expansion is 1.135 (Art. 50).

102. Weight of Steam discharged per Second.—Let A be the area of the orifice in square feet and v_2 the volume per pound at pressure p_2 , then the weight discharged per second will be

$$W = \frac{AV}{v_2} \dots \dots \dots (1)$$

Now $v_2 = v_1 \cdot \left(\frac{p_1}{p_2} \right)^{\frac{1}{n}}$

hence
$$W = \frac{A}{v_1 \cdot \left(\frac{p_1}{p_2} \right)^{\frac{1}{n}}} \sqrt{2g \cdot \frac{n}{n-1} \cdot p_1 v_1 \left\{ 1 - \left(\frac{p_2}{p_1} \right)^{\frac{n-1}{n}} \right\}}$$

$$= A \sqrt{2g \cdot \frac{n}{n-1} \cdot \frac{p_1 v_1 \left\{ 1 - \left(\frac{p_2}{p_1} \right)^{\frac{n-1}{n}} \right\}}{v_1^2 \cdot \left(\frac{p_1}{p_2} \right)^{\frac{2}{n}}}}$$

$$= A \sqrt{2g \cdot \frac{n}{n-1} \cdot \frac{p_1}{v_1} \left\{ \left(\frac{p_2}{p_1} \right)^{\frac{2}{n}} - \left(\frac{p_2}{p_1} \right)^{1+\frac{1}{n}} \right\}} \dots \dots (2)$$

Eq. (2) will give the number of pounds of steam discharged per second through an orifice A square feet in area when the fall in pressure is from any given value from p_1 to p_2 pounds per square foot.

Maximum Discharge.—The discharge will be a maximum when the expression in (2) under the root sign is a maximum, *i.e.* when

$$\left(\frac{p_2}{p_1} \right)^{\frac{2}{n}} - \left(\frac{p_2}{p_1} \right)^{1+\frac{1}{n}} \text{ is a maximum}$$

This occurs when
$$\frac{d}{d\alpha} \left(\alpha^{\frac{2}{n}} - \alpha^{1+\frac{1}{n}} \right) = 0, \text{ where } \alpha = \frac{p_2}{p_1}$$

i.e. when
$$\frac{2}{n} a^{\frac{2}{n}-1} - \left(1 + \frac{1}{n}\right) a^{\frac{1}{n}} = 0$$

or when
$$a = \left(\frac{2}{n+1}\right)^{\frac{n}{n-1}} \quad (3)$$

Inserting (3) in (2) we have for maximum discharge

$$W = A \sqrt{2g \cdot \frac{n}{n-1} \cdot \frac{p_1}{v_1} \left\{ \left(\frac{2}{n+1}\right)^{\frac{n}{n-1} \cdot \frac{2}{n}} - \left(\frac{2}{n+1}\right)^{\frac{n+1}{n} \cdot \frac{n}{n-1}} \right\}} \quad (4)$$

Substituting

$n = 1.135$ gives $\frac{p_2}{p_1} = 0.577$ from (3) and taking g as 32.2

$$W = 3.60A \sqrt{\frac{p_1}{v_1}} \quad (5)$$

or
$$W = 43.2A \sqrt{\frac{P_1}{v_1}} \quad (6)$$

where P_1 is the initial pressure in *pounds per square inch*.

The above value of $\frac{p_2}{p_1}$, namely, 0.577 , is for steam which is initially dry and saturated. In any other case the value to take for n may be estimated from Zeuner's equation (Art. 50). If this be done for a number of initial dryness fractions, varying from 1 to 0.75 , it will be found that the ratio $\frac{p_2}{p_1}$ will not differ materially from 0.58 , and that therefore this ratio may be taken for all cases of saturated steam likely to be used in practice.

When $\frac{p_2}{p_1} = \left(\frac{2}{n+1}\right)^{\frac{n}{n-1}}$ the maximum velocity will be, from (5) Art. 101,

$$\begin{aligned} V &= \sqrt{2g \frac{n}{n-1} \cdot p_1 v_1 \left\{ 1 - \left(\frac{p_2}{p_1}\right)^{\frac{n-1}{n}} \right\}} \\ &= \sqrt{2g \cdot p_1 v_1 \cdot \frac{n}{n-1} \left\{ 1 - \frac{2}{n+1} \right\}} \\ &= \sqrt{2g \cdot \frac{n}{n+1} \cdot p_1 v_1} \quad (7) \end{aligned}$$

For steam initially dry $n = 1.135$, and taking g as 32.2 this reduces to

$$V = 5.85 \sqrt{p_1 v_1} \quad (8)$$

or if P_1 is the initial pressure in *pounds per square inch*

$$V = 70.2 \sqrt{P_1 v_1} \quad (9)$$

The expression for maximum flow given in (5) may also be deduced from (8) as follows:—

$$\begin{aligned}
 W &= \frac{AV}{v_2} \\
 &= \frac{A \cdot 5 \cdot 85 \sqrt{p_1 v_1}}{v_1 \cdot \left(\frac{p_1}{p_2}\right)^{\frac{1}{n}}} \\
 &= A \cdot 5 \cdot 85 \sqrt{\frac{p_1}{v_1} \cdot \left(\frac{p_2}{p_1}\right)^{\frac{2}{n}}} \\
 &= A \cdot 5 \cdot 85 \sqrt{\frac{p_1}{v_1} \cdot \left(\frac{2}{n+1}\right)^{\frac{2}{n-1}}} \\
 &= A \cdot 5 \cdot 85 \sqrt{\frac{p_1}{v_1} \times 0 \cdot 380} \\
 &= A \cdot 5 \cdot 85 \times 0 \cdot 615 \sqrt{\frac{p_1}{v_1}} \\
 &= 3 \cdot 60 A \sqrt{\frac{p_1}{v_1}}
 \end{aligned}$$

103. Flow of Superheated Steam.—The Mollier diagram affords the most convenient means of estimating the velocity of flow, but in its absence the velocity may be calculated by the same method as Art. 102, using equation (4) in which $n = 1 \cdot 3$ for superheated steam. Since the kinetic energy per pound of steam is the same as the work done on the Rankine cycle, equation (1), Art. 58, may be used for estimating the velocity, in which case

$$\frac{V^2}{2gJ} = (T_1 - T_2) \left(1 + \frac{L_1}{T_1}\right) + C_p(T_3 - T_1) - T_2 \left(\log_e \frac{T_1}{T_2} + C_p \log_e \frac{T_3}{T_1}\right). \quad (1)$$

For a maximum discharge $\frac{p_2}{p_1} = \left(\frac{2}{n+1}\right)^{\frac{n}{n-1}}$

Substituting $n = 1 \cdot 3$ for superheated steam, we have

$$\frac{p_2}{p_1} = \left(\frac{2}{2 \cdot 3}\right)^{\frac{1 \cdot 3}{0 \cdot 3}} = 0 \cdot 545 \quad \dots \quad (2)$$

The maximum velocity will be the same as that given by (7), Art. 102, viz.—

$$V = \sqrt{2g \cdot \frac{n}{n+1} p_1 v_1}$$

Substituting $n = 1 \cdot 3$ and taking g as $32 \cdot 2$, this becomes

$$V = 60 \cdot 3 \sqrt{p_1 v_1} \quad \dots \quad (3)$$

where p_1 is the initial pressure in pounds per square foot, or if P_1 is the initial pressure in *pounds per square inch*,

$$V = 72 \cdot 36 \sqrt{P_1 v_1} \quad \dots \quad (4)$$

The maximum flow will be given by

$$\begin{aligned}
 W &= \frac{AV}{v_2} \\
 &= \frac{A \times 6.03 \sqrt{p_1 v_1}}{v_1 \left(\frac{p_1}{p_2}\right)^{\frac{1}{n}}} \\
 &= 6.03A \sqrt{\frac{p_1}{v_1} \cdot \left(\frac{p_2}{p_1}\right)^{\frac{2}{n}}} \\
 &= 6.03A \sqrt{\frac{p_1}{v_1} \cdot \left(\frac{2}{n+1}\right)^{\frac{2}{n-1}}}
 \end{aligned}$$

Substituting $n = 1.3$ for superheated steam this reduces to

$$\begin{aligned}
 W &= 6.03A \times 0.627 \sqrt{\frac{p_1}{v_1}} \\
 &= 3.786A \sqrt{\frac{p_1}{v_1}} \dots \dots \dots (5)
 \end{aligned}$$

where p_1 is in pounds per square foot,

or
$$W = 45.43 \sqrt{\frac{P_1}{v_1}} \dots \dots \dots (6)$$

where P_1 is in *pounds per square inch*.

104. Flow through Nozzles.—In the case of an orifice, when p_2 is greater than $0.58p_1$, the velocity of the issuing steam jet may be computed from either (3) or (5), Art. 101, and the discharge per second from (2), Art. 102. If the discharge takes place into a chamber in which the pressure is less than $0.58p_1$, the jet of steam will have to expand further until its pressure is reduced to that of the receiving chamber; the pressure in the jet itself, however, as it issues from the orifice will be for all practical purposes equal to $0.58p_1$. This further expansion results in a gain of velocity and therefore of kinetic energy, provided the jet is allowed to assume its natural shape. In turbine work the steam is usually allowed to expand through a larger range of pressure than is given by the ratio

$\frac{p_2}{p_1} = 0.58$, and in order that the gain of velocity may be continuous down to the final back pressure the nozzle is made divergent, as shown in Fig. 88. The inlet end of the nozzle, known as the throat, has rounded

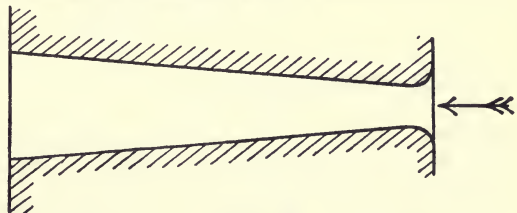

FIG. 88.

edges, and from the throat to the discharge end the nozzle is made conical. The length of the nozzle should be such that for given inlet and outlet pressures the steam completely fills it, no energy being wasted by means

of eddies. If the nozzle is made too short, eddies will be formed; if, on the other hand, it is too long, the frictional resistance becomes too large. The best length is decided upon as the result of practical experience. The diameters of the throat and discharge end are first decided, and a taper of from 1 in 20 to about 1 in 12 allowed in order to fix up the length of the nozzle.

105. Design of Nozzles.—In order to design a nozzle to pass a given weight of steam per second with given inlet and outlet pressures the first thing to do is to find the area of the throat of the nozzle, using (5) or (6), Art. 102, namely—

$$A_1 = \frac{W}{3.6} \sqrt{\frac{v_1}{p_1}} \dots \dots \dots (1)$$

The area of the discharge end (A_2) of the nozzle must next be found. This may be done by using (2), Art. 102, which gives—

$$A_2 = \frac{W}{\sqrt{2g \cdot \frac{n}{n-1} \cdot \frac{p_1}{v_1} \left\{ \left(\frac{p_2}{p_1} \right)^{\frac{2}{n}} - \left(\frac{p_2}{p_1} \right)^{1+\frac{1}{n}} \right\}}} \dots \dots (2)$$

or the velocity at discharge may be found by either of the methods given above and then the area estimated by using (1), Art. 102.

Choosing a suitable taper, say 1 in 12, the length of the nozzle from the throat to the discharge end is

$$6(d_1 - d_2)$$

The ratio between the two areas is, from (1) and (2)—

$$\begin{aligned} \frac{A_2}{A_1} &= \frac{3.6}{\sqrt{64.4 \times \frac{1.135}{0.135} \left\{ \left(\frac{p_2}{p_1} \right)^{\frac{2}{n}} - \left(\frac{p_2}{p_1} \right)^{1+\frac{1}{n}} \right\}}} \\ &= \frac{3.6}{23.2 \sqrt{\left\{ \left(\frac{p_2}{p_1} \right)^{\frac{2}{n}} - \left(\frac{p_2}{p_1} \right)^{1+\frac{1}{n}} \right\}}} \\ \therefore \frac{A_2}{A_1} &= \frac{0.155}{\sqrt{\left(\frac{p_2}{p_1} \right)^{\frac{2}{n}} - \left(\frac{p_2}{p_1} \right)^{1+\frac{1}{n}}}} \dots \dots \dots (3) \end{aligned}$$

After A_1 has been calculated the use of (3) is less laborious than (2) for estimating the value of A_2 .

106. Use of the Mollier Diagram.—The Mollier Diagram, described in Art. 48, forms a very simple and convenient means of estimating the velocity on the assumption that the flow is frictionless and adiabatic. The “heat drop,” or kinetic energy, and the velocity can be read off directly on the vertical scales arranged on the left-hand side of the diagram. The use of the diagram for this purpose will be best illustrated by means of the following examples.

EXAMPLE 1.—Dry steam in a vessel expands through a nozzle from a pressure of 200 pounds down to 140 pounds per square inch absolute.

Assuming the flow to be frictionless and adiabatic, estimate the velocity of the steam jet.

By (1), Art. 101

$$\text{kinetic energy } \frac{V^2}{2gJ} = (h_1 + L_1) - (h_2 + x_2 L_2)$$

The dryness fraction x_2 will be found to be 0.974, and using steam tables,

$$\begin{aligned} \therefore \frac{V^2}{2gJ} &= (1198.1) - (324.6 + 0.974 \times 867.6) \\ &= 1198.1 - 1168.6 \\ &= 29.5 \text{ B.Th.U.} \\ \therefore V &= \sqrt{64.4 \times 1.778 \times 29.5} \\ &= 1215 \text{ feet per second} \end{aligned}$$

Using (2), Art. 101, we have

$$\begin{aligned} \frac{V^2}{2gJ} &= (842 - 813) \left(1 + \frac{843}{842} \right) - 813 \log_e \frac{842}{813} \\ &= 29 \times 2 - 28.45 \\ &= 29.55 \text{ B.Th.U.} \end{aligned}$$

which agrees very closely with the value obtained above.

Using (5), Art. 101, we have (since p_2 is greater than $0.58p_1$)

$$\begin{aligned} V &= \sqrt{64.4 \times \frac{1.135}{1.135 - 1} \cdot 200 \times 144 \times 2.29 \left\{ 1 - \left(\frac{140}{200} \right)^{\frac{0.135}{1.135}} \right\}} \\ &= \sqrt{64.4 \times \frac{1.135}{0.135} \times 28,800 \times 2.29 \{ 1 - 0.960 \}} \\ &= 1207 \text{ feet per second} \end{aligned}$$

By means of the Mollier Diagram the velocity is read off directly and found to be 1200 feet per second.

EXAMPLE 2.—Dry steam at a pressure of 200 pounds per square inch absolute is to expand down to 5 pounds absolute. Determine the principal dimensions of the nozzle if the discharge is 60 pounds per minute.

By (6), Art. 102, the area of the throat

$$\begin{aligned} A_1 &= \frac{1}{43.2} \times \sqrt{\frac{2.29}{200}} \\ &= 0.00247 \text{ square foot or } 0.355 \text{ square inch} \end{aligned}$$

By (3), Art. 105,

$$\begin{aligned} \frac{A_2}{A_1} &= \frac{0.155}{\sqrt{\left(\frac{5}{200} \right)^{\frac{2}{1.135}} - \left(\frac{5}{200} \right)^{\frac{2.135}{1.135}}}} \\ &= \frac{0.155}{\sqrt{(0.025)^{1.762} - (0.025)^{1.881}}} = 6.81 \end{aligned}$$

hence $A_2 = 6.81 \times 0.355 = 2.417$ square inches

Alternative Solution.—From the Mollier Diagram we find the heat drop to be 253 B.Th.U., the velocity at discharge to be 3560 feet per second, and the dryness fraction 0·815. From steam tables the volume of 1 pound of dry steam at 5 pounds absolute is 73·33 cubic feet, hence the volume per pound of steam as discharged is (neglecting the volume of the water)—

$$0\cdot815 \times 73\cdot33 \text{ cubic feet}$$

$$\text{hence } 3560 A_2 = 0\cdot815 \times 73\cdot33$$

$$A_2 = \frac{0\cdot815 \times 73\cdot33}{3560}$$

$$= 0\cdot01678 \text{ square foot or } 2\cdot416 \text{ square inches}$$

107. Effect of Friction on the Flow of Steam.—In the preceding Articles it has been assumed that the flow is frictionless as well as adiabatic. Actually, there is a frictional resistance between the steam and the sides of the nozzle and also an internal resistance between the particles of steam themselves. In the theory already considered, the kinetic energy of the steam is represented by the area $abcd$ on the temperature-entropy diagram (Fig. 89). The actual kinetic energy is less than this amount because of the energy wasted in overcoming frictional resistance. The energy so lost is absorbed, as heat, by the steam, with the result that the steam is drier on leaving the nozzle than it would have been if the flow were frictionless; or expressed in other words, the steam contains more heat on leaving the nozzle and less kinetic energy than in the ideal case when the frictional resistance is nil.

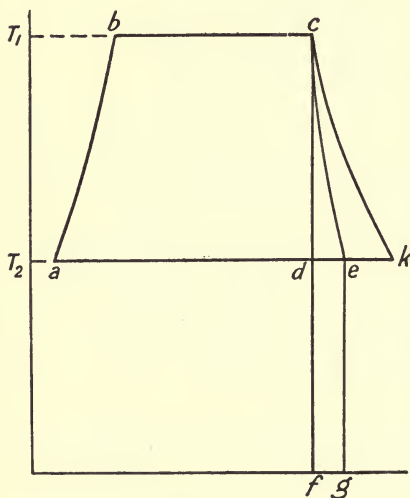

FIG. 89.

At the end of expansion the steam is in the condition represented by the point e (Fig. 89), the expansion being represented by some such approximately straight line as ce . The total kinetic energy generated (including that utilised in overcoming friction) is represented by the area $abce$, the amount lost in friction by the area $fceg$, hence the net amount of kinetic energy available is equal to

$$\begin{aligned} & \text{area } abce - \text{area } fceg \\ &= \text{area } abcd - \text{area } fdeg \end{aligned}$$

The actual position of the point e is difficult to decide, and in practice when allowing for frictional resistance de is usually made equal to about $\frac{1}{3} dk$.

EXAMPLE.—An impulse turbine of the de Laval type is to develop 250 H.P. with a probable consumption of 15·5 pounds of steam per H.P. hour, the initial pressure being 180 pounds and the exhaust 2 pounds per

square inch absolute. Taking the diameter at the throat of each nozzle as $\frac{1}{4}$ inch, find the number of nozzles required. Assuming that 12 per cent. of the heat drop is lost in the diverging part of the nozzle, find the diameter at the exit of the nozzle and the quality of the steam, which is to be fully expanded as it leaves the nozzle. (L.U.)

By (6), Art. 102, the weight discharged per second from each nozzle will be

$$W = 43.2A \sqrt{\frac{P_1}{v_1}}$$

$$W = \frac{43.2}{144} \times \frac{\pi}{4} \times \left(\frac{1}{4}\right)^2 \sqrt{\frac{180}{2.53}} = 0.1213 \text{ pound}$$

$$\text{Total steam required per second} = \frac{250 \times 15.5}{60 \times 60} = 1.076 \text{ pounds}$$

$$\text{Number of nozzles} = \frac{1.076}{0.1213} = 8.8, \text{ say } 9 \text{ nozzles}$$

If the expansion were frictionless and adiabatic from 180 pounds to 2 pounds absolute, the kinetic energy of the jet at exit from the nozzle would be

$$\frac{V^2}{2g} = \frac{n}{n-1} \cdot p_1 v_1 \left\{ 1 - \left(\frac{p_2}{p_1}\right)^{\frac{n-1}{n}} \right\} \quad (5), \text{ Art. 101}$$

Since 12 per cent. of this heat drop is lost, the kinetic energy will be 88 per cent. of the above, namely—

$$\begin{aligned} \frac{V^2}{2g} &= 0.88 \times \frac{1.13}{0.13} \times 144 \times 180 \times 2.53 \left\{ 1 - \left(\frac{2}{180}\right)^{\frac{0.13}{1.13}} \right\} \\ &= 202,700 \text{ foot-pounds, or } 260 \text{ B.Th.U.} \end{aligned}$$

and the velocity

$$V = \sqrt{64.4 \times 202,700} = 3610 \text{ feet per second}$$

From steam tables (p. 480) we find the total heat of dry saturated steam at 180 pounds absolute is

$$1196.4 \text{ B.Th.U.}$$

Hence the total heat per pound after expansion to 2 pounds absolute is

$$h_2 + x_2 L_2 = 1196.4 - 260 = 936.4$$

Substituting for h_2 and L_2 from steam tables

$$\begin{aligned} 94 + x_2 \times 1021 &= 936.4 \\ x_2 &= 0.825 \end{aligned}$$

$$\text{Volume per pound} = 0.825 \times 173.5 \text{ cubic feet}$$

$$\therefore \text{ area of nozzle at exit} = \frac{0.1213 \times 0.825 \times 173.5}{3610}$$

$$= 0.00481 \text{ square foot}$$

$$= 0.693 \text{ square inch}$$

$$\therefore \text{ diameter of nozzle at exit} = \sqrt{\frac{0.693}{0.7854}} = 0.939 \text{ inch}$$

108. Theory of the Injector.—The action of an injector will be understood by reference to Fig. 90. The steam used for working the injector expands through the conical nozzle A, issuing therefrom with a high velocity, and coming into contact with cold water flowing in from the feed tank E, is condensed in the convergent combining tube or cone B. The resulting jet of water enters the divergent delivery tube or cone C, and at its smallest cross-section is moving with its maximum velocity. The kinetic energy of the jet of water is then converted into pressure energy in its passage along the delivery tube, its pressure increasing as its velocity decreases, until on leaving the tube the pressure is greater than the boiler pressure and the water enters the boiler. An outlet is provided at D through which any excess of water may overflow when starting.

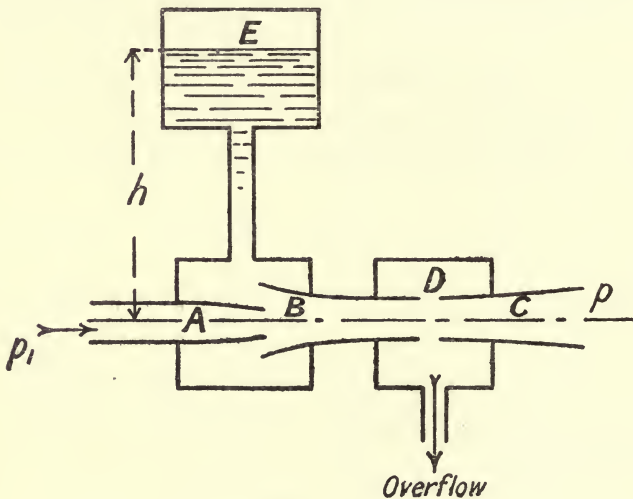

FIG. 90.

The velocity of the issuing steam jet may be estimated by either of the methods already given. Let V be the velocity of the steam jet in feet per second, p_1 the initial steam pressure, and p_2 the pressure in the jet just outside the steam nozzle where contact occurs between the steam and the entering water, then V may be calculated from either of the following equations:—

$$V = \sqrt{2gJ\left\{(T_1 - T_2)\left(1 + \frac{x_1 L_1}{T_1}\right) - T_2 \log_e \frac{T_1}{T_2}\right\}} \quad (\text{see (3), Art. 101})$$

$$\text{or } V = \sqrt{2g \cdot \frac{n}{n-1} \cdot p_1 v_1 \left\{1 - \left(\frac{p_2}{p_1}\right)^{\frac{n-1}{n}}\right\}} \quad (\text{see Art. 101})$$

It is usual to assume $p_2 = 0.6p_1$, or if the ratio for maximum discharge be assumed, namely $p_2 = 0.577p_1$, then

$$V = 5.85 \sqrt{p_1 v_1} \quad (\text{see (8), Art. 102})$$

or

$$V = 70.2 \sqrt{P_1 v_1}$$

where P_1 is the initial pressure in pounds per square inch.

Weight of Water per Pound of Steam.—Let W be the number of pounds of water drawn from the feed tank per pound of steam, h the head of water in feet on the injector (see Fig. 90), p the boiler pressure in pounds per square foot, and H the height, in feet, of the boiler feed check valve above the delivery cone of the injector, then neglecting losses the least velocity of the jet V_j entering the delivery cone will be given by

$$\frac{V_j^2}{2g} = \frac{p}{62.4} + H. \dots \dots \dots (1)$$

In actual practice p in (1) should be taken about 20 per cent. greater than the absolute boiler pressure to ensure that the injector works properly.

The velocity with which the water will flow into the injector under the head of h feet will be

$$\sqrt{2gh}$$

the momentum of W pounds of this water will be

$$\frac{W}{g} \sqrt{2gh}$$

the momentum of 1 pound of steam moving with velocity V will be

$$\frac{V}{g}$$

and the momentum of the resulting jet

$$\frac{(W + 1)V_j}{g}$$

Hence, equating the momentum before to that after combining we have

$$\frac{(W + 1)V_j}{g} = \frac{V}{g} + \frac{W}{g} \sqrt{2gh}$$

or

$$V_j = \frac{V}{W + 1} + \frac{W}{W + 1} \sqrt{2gh} \dots \dots \dots (2)$$

If the water is not supplied under pressure to the injector but the feed tank is h feet below the injector, as is the case of injectors of the lifting type, equation (2) becomes

$$V_j = \frac{V}{W + 1} - \frac{W}{W + 1} \sqrt{2gh} \dots \dots \dots (2A)$$

In most cases the term $\frac{W}{W + 1} \sqrt{2gh}$ is so small that it may be neglected.

By substituting the value of V_j obtained from (1) in (2) the value of W may be found.

Estimation of the Feed Temperature.—Let t be the temperature of the water in the feed tank and t_3 the temperature of the delivery from the injector, *i.e.* the feed temperature to the boiler. Then per pound of steam used

$$\text{Kinetic energy of the jet} = \frac{(W + 1)}{2g} \cdot \frac{V_j^2}{J} \text{ in heat units}$$

$$\text{heat gained by } W \text{ pounds of water} = W(t_3 - t)$$

$$\text{heat lost by 1 pound of steam} = x_1 L_1 + (t_1 - t_3)$$

equating the heat lost by the steam to the heat gained by the water, we get

$$x_1 L_1 + (t_1 - t_3) = W(t_3 - t) + \frac{(W + 1) \cdot V_j^2}{2g \cdot J} \quad \dots (3)$$

from which t_3 may be estimated.

The kinetic energy of the jet is usually so small in comparison with the other items in (3) that for practical purposes it may be neglected.

Area of Steam Nozzle.—The dryness fraction, x_2 , of the steam at pressure p_2 (or $0.6 p_1$) is found from a temperature-entropy diagram, or by calculation from

$$x_2 = \frac{T_2}{L_2} \left(\frac{x_1 L_1}{T_1} + \log_e \frac{T_1}{T_2} \right) \text{ (see (3), Art. 46)}$$

Let w pounds be the weight of steam used per second and v_2 the specific volume at pressure p_2 , then, neglecting the volume of the water it contains, its volume will be

$$w \times x_2 v_2$$

$$\text{and the area of the steam nozzle} = \frac{w \times x_2 v_2}{V} \quad \dots (4)$$

Area of Water-discharge Orifice.—The quantity of water drawn from the feed tank per second will be $w \times W$ pounds, or

$$\frac{w \cdot W}{62.4} \text{ cubic feet}$$

hence,

$$\text{area of the discharge end of the combining nozzle} = \frac{w \cdot W + w}{62.4 V_j} \quad (5)$$

109. Types of Injectors.—Injectors may be divided into two classes, “non-automatic” and “automatic,” or self-acting injectors.

Non-automatic injectors do not restart automatically if for any reason the discharge is interrupted; and further, both the steam and water must be independently regulated by hand when starting in the first instance, or when restarting in the event of any discontinuity in the discharge.

Non-automatic Injectors are further divided into two classes, namely—

(a) *Non-automatic Lifting Injectors* which lift their feed water and usually have adjustable cones, that is to say, their cones can be adjusted to suit a great variety of conditions and a wider range of steam pressures than non-adjusting injectors.

(b) *Non-automatic Non-lifting Injectors* which do not lift, but require their feed water to flow to them under pressure.

Automatic or Self-acting Injectors, on the other hand, lift their feed water if required, and start working as soon as steam and water are turned on, without any manipulation. They will also restart instantaneously and automatically should the jet be accidentally broken.¹

EXAMPLE I.—Calculate the area of the orifices of a live steam injector to take 1000 gallons of water per hour from the feed tank to a boiler, the absolute steam pressure being 165 pounds per square inch. The steam supplied to the injector may be assumed dry, the pressure in the steam

¹ For the description of various types of injectors, see the author’s “Steam Boilers” (Edward Arnold).

orifice 0.6 of the boiler pressure, and the temperature of the water in the feed or suction tank 60° F.

The pressure in the steam jet = 0.6 × 165 = 99 pounds absolute.

From steam tables we find—

p	t	v	L	H	T
165	366	2.753	856.8	1195.0	826
99	327	4.47	886.6	1186.2	787

From (3), Art. 101,

$$V = \sqrt{64.4 \times 778 \left\{ (826 - 787) \left(1 + \frac{856.8}{826} \right) - 787 \log_e \frac{826}{787} \right\}}$$

$$= 1420 \text{ feet per second}$$

The dryness fraction $x_2 = \frac{787}{886.6} \left(\frac{856.8}{826} + \log_e \frac{826}{787} \right)$

$$= 0.963$$

(Note.—Both V and x_2 could be obtained directly from a Mollier Diagram.)

From (1), Art. 108, we have, neglecting H

$$\frac{V_j^2}{64.4} = \frac{1.2 \times 165 \times 144}{62.4}$$

from which $V_j = 171$ feet per second

Neglecting the second term on the right-hand side of (2), Art. 108, we have

$$171 = \frac{1420}{W + 1}$$

$$W = \frac{1420 - 171}{171} = 7.30 \text{ pounds}$$

The feed water drawn from the feed tank per hour is 10,000 pounds = $\frac{10,000}{3600}$ pounds per second, hence the weight of steam used per second is

$$\frac{10,000}{3600 \times 7.30} \text{ pounds}$$

and by (4), Art. 108, the area of the steam nozzle will be

$$\frac{10,000}{3600 \times 7.30} \times \frac{0.963 \times 4.47}{1420}$$

$$= 0.00115 \text{ square feet}$$

$$= 0.00115 \times 144 = 0.166 \text{ square inch}$$

The discharge from the injector per hour will be

$$10,000 + \frac{10,000}{7.3}$$

$$= 11,700 \text{ pounds}$$

$$= \frac{11,700}{3600} \text{ pounds per second}$$

and by (5), Art. 108, the area of the water discharge orifice will be

$$\begin{aligned} & \frac{11,700}{3600 \times 62.4 \times 171} \\ &= 0.000304 \text{ square foot} \\ &= 0.0438 \text{ square inch} \end{aligned}$$

The feed temperature will be by (3), Art. 108

$$856.8 + (366 - t_3) = 7.30 (t_3 - 60) + \frac{8.30}{64.4} \cdot \frac{171 \times 171}{778}$$

from which $t_3 = 199^\circ \text{F}$.

EXAMPLE 2.—Calculate the diameter of the orifices for an injector to deliver 1200 gallons of water per hour into a boiler containing steam at 60 pounds per square inch absolute. The steam supplied to the injector may be assumed dry, the pressure in the steam orifice 0.6 of the absolute boiler pressure, the temperature of water in the suction tank 100°F ., and the temperature of the feed water 180°F . (L.U.)

Taking the necessary data from steam tables we have

$$\begin{aligned} V &= \sqrt{64.4 \times 778 \left\{ (753 - 721) \left(1 + \frac{914.9}{753} \right) - 721 \log_e \frac{753}{721} \right\}} \\ &= 1400 \text{ feet per second} \end{aligned}$$

$$\begin{aligned} \text{The dryness fraction } x_2 &= \frac{721}{937.7} \left(\frac{914.9}{753} + \log_e \frac{753}{721} \right) \\ &= 0.970 \end{aligned}$$

The feed temperature is here given as 180°F ., the weight of water per pound of steam may therefore be estimated as follows.

From (3), Art 108, we have (neglecting the kinetic energy of the jet)

$$\begin{aligned} 914.9 + 293 - 180 &= W(180 - 100) \\ W &= 12.84 \text{ pounds} \end{aligned}$$

The velocity of the jet, neglecting the second term on the right-hand side of (2), Art. 108, is

$$V_j = \frac{1400}{13.84} = 101 \text{ feet per second}$$

Assuming that the water drawn from the suction feed tank is 12,000 pounds per hour, the weight of steam used per second is

$$\frac{12,000}{12.84 \times 3600} \text{ pounds}$$

and by (4), Art. 108, the area of the steam orifice will be

$$\begin{aligned} & \frac{12,000}{12.84 \times 3600} \times \frac{0.970 \times 11.58}{1400} \times 144 \\ &= 0.295 \text{ square inch} \end{aligned}$$

$$\text{hence the diameter} = \sqrt{\frac{0.295}{0.7854}} = 0.613 \text{ inch}$$

The discharge from the injector per hour will be

$$\begin{aligned} 12,000 \times \frac{12,000}{12.84} \\ = 12,934 \text{ pounds} \\ = \frac{12,934}{3600} \text{ pounds per second} \end{aligned}$$

and by (5), Art. 108, the area of the water discharge orifice will be

$$\begin{aligned} \frac{12,934}{3600 \times 62.4 \times 101} \times 144 \\ = 0.0821 \text{ square inch} \end{aligned}$$

$$\text{hence the diameter} = \sqrt{\frac{0.0821}{0.7854}} = 0.323 \text{ inch}$$

The above areas have been designed for a given feed-water temperature and the injector may or may not work. The pressure of the water at the feed check valve will be from (1), Art. 108,

$$\frac{101 \times 101}{64.4} = \frac{p \times 144}{62.4}$$

$$p = \frac{101 \times 101 \times 62.4}{144 \times 64.4} = 68.6 \text{ pounds per square inch absolute}$$

Since the absolute boiler pressure is 60 pounds per square inch it is evident that the injector will work against this pressure.

EXAMPLES VIII

1. Boiler steam of dryness fraction 0.98 and pressure 150 pounds per square inch absolute expands through a nozzle down to a pressure of 100 pounds absolute. Assuming the flow to be frictionless and adiabatic, estimate the velocity and dryness fraction of the steam jet.

2. Dry steam at a pressure of 180 pounds per square inch absolute expands through a properly designed nozzle down to a pressure of 3 pounds absolute. Determine the areas of the throat and discharge end of the nozzle to discharge 3000 pounds per hour, and state the dryness fraction at these places on the assumption that the flow is frictionless and adiabatic.

3. Superheated steam at a pressure of 200 pounds absolute and with 100° F. superheat (volume per pound = 2.68 cubic feet) expands through a nozzle down to 15 pounds absolute. Determine the principal dimensions of the nozzle to discharge 3600 pounds per hour, and state the condition of the steam in the throat and at the discharge end. Assume frictionless and adiabatic flow.

4. An exhaust steam injector is to be used for feeding a locomotive boiler in which the steam pressure is 200 pounds absolute. If the pressure of the exhaust steam for working the injector is 17 pounds absolute and its dryness fraction is 0.85, estimate the weight of water that can be pumped per pound of steam, the area of the steam and of the water discharge orifice, and the feed temperature, if the weight of water taken from the feed tank is 10,000 pounds per hour at a temperature of 50° F.

CHAPTER IX

THEORY OF THE STEAM TURBINE

110. Function of a Steam Turbine.—The steam turbine is a machine which converts heat energy into kinetic energy, and the kinetic energy into a form in which it can do mechanical work. Kinetic energy is generated in a series of nozzles or vanes, and the steam, issuing therefrom at a high velocity, impinges on another series of moving vanes or buckets and gives up some of its kinetic energy to them. In the ideal turbine the steam would leave the moving vanes with zero velocity

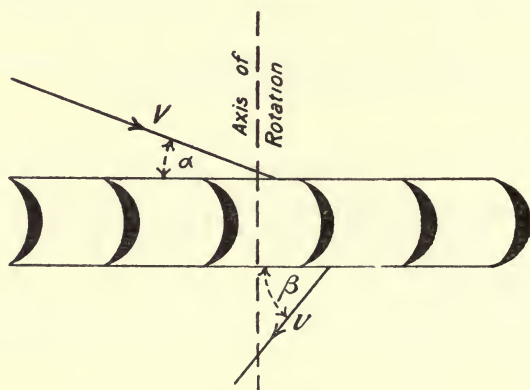

FIG. 91.

(relative to the turbine casing) and all its kinetic energy would be changed into work done on the rotating vanes. The turbine is enabled to do this by changing the momentum of the steam in its passage through the moving vanes, the change of momentum per second constituting the driving force on these vanes.

Let V be the absolute velocity of the steam as it impinges on the moving blades, and v the absolute velocity as it leaves them, then the change of momentum per second of 1 pound of steam in the direction of motion of the blades is

$$\frac{V \cos \alpha + v \cos \beta}{g} \text{ (see Fig. 91)}$$

If W pounds of steam are supplied per second the driving force on the vanes will be

$$\frac{W}{g}(V \cos \alpha + v \cos \beta)$$

And if V_b be the velocity of the vanes, the work done per second by W pounds of steam will be

$$\frac{W}{g}(V \cos \alpha + v \cos \beta) \cdot V_b \dots \dots \dots (1)$$

or, the work done per pound of steam per second will be

$$U = \frac{V_b}{g}(V \cos \alpha + v \cos \beta) \dots \dots \dots (2)$$

The velocity diagram is shown in Fig. 92. AB represents the absolute velocity V at an angle α with the direction of motion of the vanes, and V_b

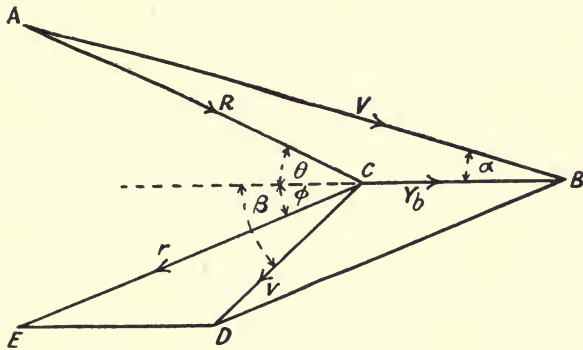

FIG. 92.

the velocity of the blades. AC will therefore represent the velocity of the steam (R) at entrance *relative to the blades*; let its direction be inclined θ to V_b , as shown.

The absolute velocity v of the steam leaving the blades is represented by CD at angle β , whilst CE will represent the velocity of the steam (r) *relative to the blades* at exit; let it be inclined ϕ to V_b , as shown.

Now the work done per pound of steam per second is

$$U = \frac{V_b}{g}(V \cos \alpha + v \cos \beta)$$

and since BD is equal and parallel to CE ,

$$CD \cos \beta + CB = CE \cos \phi$$

$$\therefore CD \cos \beta = CE \cos \phi - CB$$

But
 hence $AB \cos \alpha + CD \cos \beta = AC \cos \theta + CE \cos \phi$
 or, $V \cos \alpha + v \cos \beta = R \cos \theta + r \cos \phi$

Hence (2) may be written—

$$U = \frac{V_b}{g}(R \cos \theta + r \cos \phi) \dots \dots \dots (3)$$

III. Impulse and Reaction Turbines.—In impulse turbines the fall of pressure and generation of kinetic energy takes place in a set, or sets, of fixed nozzles or blades only. In reaction turbines the fall of pressure and generation of kinetic energy takes place partly in the fixed and partly in the moving blades. During the first portion of its motion through the moving blades kinetic energy is taken from the steam, and consequently its velocity is reduced; but in the latter portion the velocity is increased by a suitable arrangement of the blades, and therefore generation of kinetic energy takes place whilst work is being done on the moving blades. A hard-and-fast line of distinction cannot be drawn between the two types, and many modern turbines are a combination of both the purely impulse and the purely reaction types.

III. Single Stage Turbines.—The De Laval turbine is the best

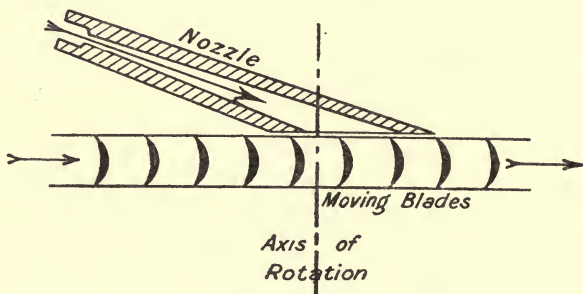

FIG. 93.

known and most extensively used single-stage turbine. It is a pure impulse turbine, and in it the steam is expanded in nozzles from the initial down to the exhaust pressure before being directed on to a ring of moving blades fixed on the circumference of a rotating wheel, as shown diagrammatically in Fig. 93. The velocity diagram is shown in Fig. 94. Neglecting all losses, the work done on the moving blades per pound of steam will be equal to the difference between the initial and final kinetic energy of the steam, viz.

$$\frac{V^2}{2g} - \frac{v^2}{2g}$$

and the efficiency of the blades or turbine wheel will be

$$E = \frac{V^2 - v^2}{V^2} \dots \dots \dots (1)$$

The Speed of the Wheel to give Maximum Efficiency.—**Case I.** Suppose V and α to be fixed and $\theta = \phi$, then using the same notation as in Art. 110, we have, since $r = R$,

$$CD^2 = CB^2 + CE^2 - 2 \cdot CB \cdot CE \cos \phi$$

$$= CB^2 + AC^2 - 2 \cdot CB \cdot AC \cos \theta \dots (2)$$

or,

$$v^2 = V_b^2 + R^2 - 2 \cdot V_b \cdot R \cos \theta \dots (3)$$

$$= V_b^2 + r^2 - 2V_b r \cos \theta$$

Since $AC \cos \theta = FC$ (2) may be written

$$CD^2 = CB^2 + AC^2 - 2 \cdot CB \cdot FC$$

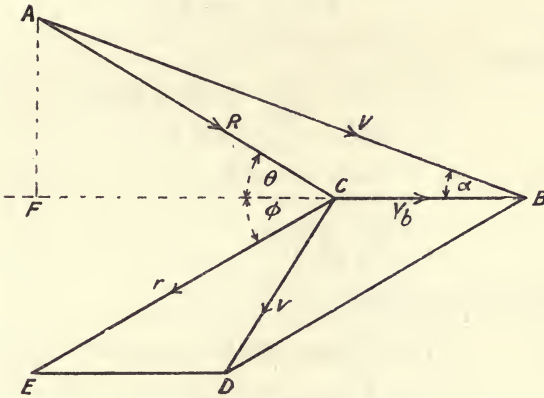

FIG. 94.

The efficiency will be a maximum when CD or v is a minimum, *i.e.* when $CB \cdot FC$ is a maximum. This occurs when $CB = FC$, or when

$$V_b = R \cos \theta \dots (3A)$$

Also since

$$CB = FC$$

$$FB = 2CB = V \cos \alpha$$

$$\therefore CB = V_b = \frac{V}{2} \cos \alpha$$

Hence v is a minimum when

$$V_b = R \cos \theta = \frac{V}{2} \cos \alpha \dots (4)$$

and since

$$FB = 2FC$$

$$\tan \theta = 2 \tan \alpha \dots (5)$$

In practice α is small (in the De Laval turbine it is about 20°), and therefore $\cos \alpha$ will be very nearly equal to unity, hence the maximum efficiency will be obtained when the velocity of the blades is approximately equal to *half* the velocity of the steam jet.

Efficiency of the Blades—The work done per pound of steam per second is by (3), Art. 110

$$V = \frac{V_b}{g} (R \cos \theta + r \cos \phi)$$

$$= \frac{V_b}{g} (R \cos \theta + R \cos \theta)$$

$$= \frac{2 V_b \cdot R \cos \theta}{g} \dots (6)$$

Substituting for R from (3A)

$$U = \frac{2V_b^2}{g}$$

and since by (4)

$$V_b = \frac{V}{2} \cos \alpha$$

$$U = \frac{1}{2} \frac{V^2}{g} \cos^2 \alpha \dots \dots \dots (7)$$

By (3) above

$$v^2 = V_b^2 + R^2 - 2 \cdot V_b \cdot R \cos \theta$$

hence

$$v^2 = V_b^2 + \frac{V_b^2}{\cos^2 \theta} - 2 \cdot V_b^2$$

$$= V_b^2(1 + \sec^2 \theta - 2)$$

$$= V_b^2(\sec^2 \theta - 1)$$

$$= V_b^2 \cdot \tan^2 \theta$$

$$\therefore v = V_b \tan \theta \dots \dots \dots (8)$$

From (4) and (5) we have

$$V_b = \frac{V}{2} \cos \alpha, \tan \theta = 2 \tan \alpha$$

Hence

$$v = \frac{V}{2} \cos \alpha \cdot 2 \tan \alpha$$

$$= V \sin \alpha \dots \dots \dots (9)$$

Neglecting all losses, the efficiency is

$$E = \frac{V^2 - v^2}{V^2}$$

$$= \frac{V^2 - V^2 \sin^2 \alpha}{V^2}$$

$$= 1 - \sin^2 \alpha$$

$$\therefore E = \cos^2 \alpha \dots \dots \dots (10)$$

The efficiency might also be deduced as follows ; it will be

$$E = \frac{\text{work done on the blades}}{\text{initial kinetic energy of the steam}}$$

$$= \frac{V}{\frac{1}{2}v^2} \cdot g = \cos^2 \alpha \text{ from (7)}$$

Effect of Friction.—Frictional and eddy losses will tend to make r less than R. On the other hand, any kinetic energy that may be developed by the steam in its passage through the moving blades will tend to make r greater than R. Hence r may be either less than R, equal to R, or greater than R.

In general terms, therefore, we may assume that in actual practice $r = kR$, where k is a constant.

Equation (3) will therefore become

$$v^2 = V_b^2 + k^2R^2 - 2V_bk \cdot R \cos \theta \dots \dots \dots (11)$$

As before, this will be a minimum when

$$V_b = R \cos \theta = \frac{V}{2} \cos \alpha$$

Equation (3), Art. 110, will become

$$\begin{aligned} U &= \frac{V_b}{g} (R \cos \theta + kR \cos \theta) \\ &= \frac{V_b}{g} \cdot R \cos \theta (1 + k) \\ &= \frac{V_b^2}{g} (1 + k) \\ \therefore U &= \frac{1}{4} V^2 \cos^2 \alpha (1 + k) \quad \dots \dots \dots (12) \end{aligned}$$

Equation (11) becomes, since $V_b = R \cos \theta$

$$\begin{aligned} v^2 &= V_b^2 + k^2 \cdot \frac{V_b^2}{\cos^2 \theta} - 2V_b^2 \cdot k \\ &= V_b^2 (1 + k^2 \sec^2 \theta - 2k) \\ &= V_b^2 (k^2 + k^2 \tan^2 \theta + 1 - 2k) \\ &= V_b^2 \{ k^2 \tan^2 \theta + (k - 1)^2 \} \quad \dots \dots \dots (13) \end{aligned}$$

Substituting for V_b in (13), from (4) and (5)

$$\begin{aligned} v^2 &= \frac{1}{4} V^2 \cdot \cos^2 \alpha \{ k^2 4 \tan^2 \alpha + (k - 1)^2 \} \\ &= k^2 V^2 \sin^2 \alpha + \frac{1}{4} V^2 \cos^2 \alpha (k - 1)^2 \quad \dots \dots \dots (14) \end{aligned}$$

The efficiency of the blades will now be

$$E = \frac{U}{\frac{1}{2} V^2 \cdot g} = \frac{1}{2} \cos^2 \alpha (1 + k) \quad \dots \dots \dots (15)$$

When $k = 1$, equations (12), (14), and (15), reduce to (7), (9), and (10) respectively.

Case II. Suppose V is fixed in magnitude only, θ and ϕ being fixed but not equal. Then neglecting frictional resistance

$$\begin{aligned} CD^2 &= CB^2 + AC^2 - 2 \cdot CB \cdot AC \cos \phi \\ v^2 &= V_b^2 + R^2 - 2 \cdot V_b \cdot R \cos \phi \quad \dots \dots \dots (16) \end{aligned}$$

In this case v will be a minimum when $CB \cdot AC$ is a maximum, *i.e.* when $AC = CB$, and the triangle ABC is isosceles.

Hence

$$\theta = 2\alpha$$

$$\therefore AC = CB = \frac{AB}{2 \cos \alpha} = \frac{AB}{2 \cos \frac{\theta}{2}}$$

or,

$$R = V_b = \frac{V}{2} \sec \alpha = \frac{V}{2} \sec \frac{\theta}{2} \quad \dots \dots \dots (17)$$

And from (16) and (17) we have

$$\begin{aligned} v^2 &= 2 \cdot \frac{V^2}{4} \sec^2 \frac{\theta}{2} - 2 \cdot \frac{V^2}{4} \sec^2 \frac{\theta}{2} \cdot \cos \phi \\ &= \frac{V^2}{4} \sec^2 \frac{\theta}{2} (2 - 2 \cos \phi) \quad \dots \dots \dots (18) \end{aligned}$$

Now the work done per pound of steam per second is

$$U = \frac{V_b}{g}(R \cos \theta + r \cos \phi)$$

Substituting for V_b and R from (17)

$$U = \frac{V^2}{4g} \sec^2 \frac{\theta}{2} (\cos \theta + \cos \phi) \dots \dots \dots (19)$$

The efficiency of the blades will be

$$\begin{aligned} E &= \frac{U}{\frac{1}{2}V^2} \cdot g \\ &= \frac{1}{2} \sec^2 \frac{\theta}{2} (\cos \theta + \cos \phi) \\ &= \frac{\cos \theta + \cos \phi}{2 \cos^2 \frac{\theta}{2}} \\ &= \frac{\cos \theta + \cos \phi}{1 + \cos \theta} \dots \dots \dots (20) \end{aligned}$$

Hence in this case for maximum efficiency we must have

$$V_b = \frac{V}{2} \sec \frac{\theta}{2} \dots \dots \dots (17 \text{ above})$$

$$V = \frac{V^2}{4g} \cdot \sec^2 \frac{\theta}{2} (\cos \theta + \cos \theta) \dots \dots (19 \text{ above})$$

$$E = \frac{\cos \theta + \cos \theta}{1 + \cos \theta} \dots \dots \dots (20 \text{ above})$$

Effect of Friction.—Writing $r = kR$ the above expressions will be found to reduce to

$$V_b = \frac{V}{2} \sec \frac{\theta}{2} \text{ as before, see (17)}$$

$$U = \frac{V^2}{4g} \cdot \sec^2 \frac{\theta}{2} (\cos \theta + k \cos \phi) \dots \dots \dots (21)$$

$$E = \frac{\cos \theta + k \cos \phi}{1 + \cos \theta} \dots \dots \dots (22)$$

Effect of Vane Speed on the Efficiency.—Assuming that $r = R$, we have from Fig. 94

$$v^2 = R^2 + V_b^2 - 2RV_b \cos \phi \dots \dots \dots (23)$$

and $R^2 = V^2 + V_b^2 - 2VV_b \cos \alpha \dots \dots \dots (24)$

(24) in (23) gives

$$\begin{aligned} v^2 &= V^2 + V_b^2 - 2VV_b \cos \alpha + V_b^2 - 2V_b \cos \phi \sqrt{V^2 + V_b^2} - 2VV_b \cos \alpha \\ &= V^2 + 2V_b^2 - 2VV_b \cos \alpha - 2V_b \cos \phi \sqrt{V^2 + V_b^2} - 2VV_b \cos \alpha \end{aligned}$$

$$\therefore E = \frac{V^2 - v^2}{V^2}$$

$$= -2 \frac{\{V_b^2 - VV_b \cos \alpha - V_b \cos \phi \sqrt{V^2 + V_b^2} - 2VV_b \cos \alpha\}}{V^2}$$

Writing $V_b = nV$ where $n < 1$, we have

$$E = -2 \frac{\{n^2 V^2 - nV^2 \cos \alpha - nV \cos \phi \sqrt{V^2 + n^2 V^2 - 2nV^2 \cos \alpha}\}}{V^2}$$

$$= -2n \{n - \cos \alpha - \cos \phi \sqrt{1 - 2n \cos \alpha + n^2}\}$$

or $E = 2n \{ \cos \alpha + \cos \phi \sqrt{1 - 2n \cos \alpha + n^2} - n \}$ (25)

Taking $\alpha = \phi = 20^\circ$ the following table shows the value of E for various values of n :—

n	E
0.2	0.604
0.3	0.789
0.4	0.913
0.5	0.966
0.6	0.949
0.7	0.880
0.8	0.784
0.9	0.666
1.0	0.540

The above values of n and E are shown plotted in Fig. 94A, from which it will be seen that the maximum efficiency (neglecting friction) of

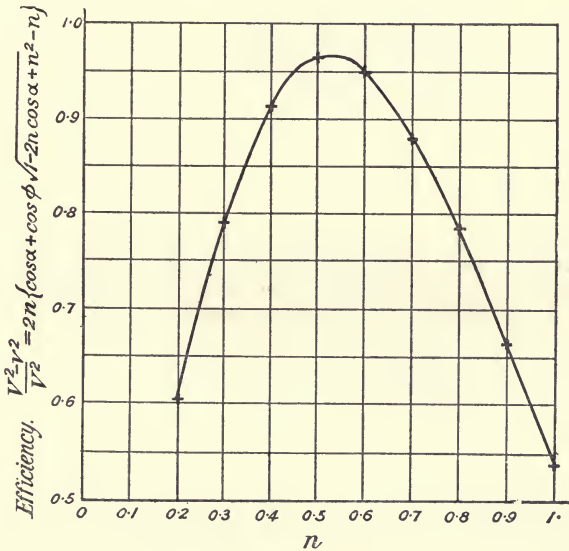

FIG. 94A.

the blades occurs when n is approximately equal to 0.5, i.e. when the vane speed is approximately equal to half the initial speed of the steam.

In the special case when $\theta = \phi = 0$ the running speed of the wheel

blades (V_b) is $\frac{V}{2}$ for the maximum efficiency of unity. This is the case of the Pelton wheel type of blades. In all other cases considered above V_b is approximately equal to $\frac{V}{2}$, since θ being fairly small, both $\cos \theta$ and $\sec \frac{\theta}{2}$ will be approximately equal to unity.

In the De Laval turbine the initial velocity of the steam is very high (see Ex. 2, p. 177), hence the running speed of the blades would be excessively high if the above value be taken. The inclination of the nozzle to the plane of the wheel (α) is usually made about 20° , and on account of the enormous value of the centrifugal force, the wheel is run at a lower speed with a reduction in blade efficiency. The blade speed varies in practice from about 500 feet per second in the small sizes to about 1400 feet per second in the largest sizes.

113. Multi-Stage Turbines.—The Rateau and the Zoelly are the best known turbines of this type. The principle of these turbines will be understood after reference to Fig. 95. The total expansion from the initial to the exhaust pressure is divided up into a number of stages, each of which is made up of a ring of nozzles and a ring of moving blades, being essentially a De Laval turbine with a small drop in pressure. Each ring of moving wheels is mounted on a separate wheel, which is

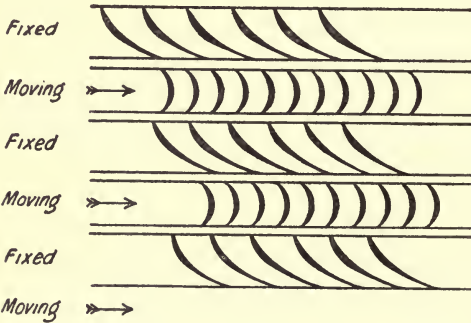

FIG. 95.—Rateau blading.

keyed to the rotor shaft, and the steam only exerts one effort on the moving blades in each stage. By this means the speed of the turbine is reduced, there being from twenty to thirty stages in the Rateau and about ten in the Zoelly turbine. For a given range of steam pressure, therefore, the Rateau runs at a lower speed than the Zoelly turbine.

The number of stages is decided with reference to the total pressure drop in such a manner that the necessary velocity of the steam is obtained, which, with a reasonable speed of wheel, will give a satisfactory blade efficiency. M. Zoelly¹ selects a ratio of pressure fall per stage of $\frac{p_1}{p_2} = 1.73$ as giving the best combination of efficiency and practical constructional economy, where p_1 = the initial steam-pressure, and p_2 the final steam-pressure in the same stage. With an initial steam-pressure of 10 atmospheres absolute and an exhaust pressure of 0.1 atmosphere absolute this pressure ratio per stage requires nine stages, giving a steam velocity of about 1600 feet per second, and requiring a peripheral speed of the blades of about 700 feet per second.

¹ See *Proc. Inst. Mech. E.*, p. 686, July, 1911.

By using from twenty to thirty stages in the Rateau turbine, depending upon the total pressure drop, the speed of the moving blades is reduced to about 350 feet per second.¹

The velocity diagram for both the Rateau and the Zoelly turbines is shown in Fig. 96. It consists of a series of diagrams, each similar to that

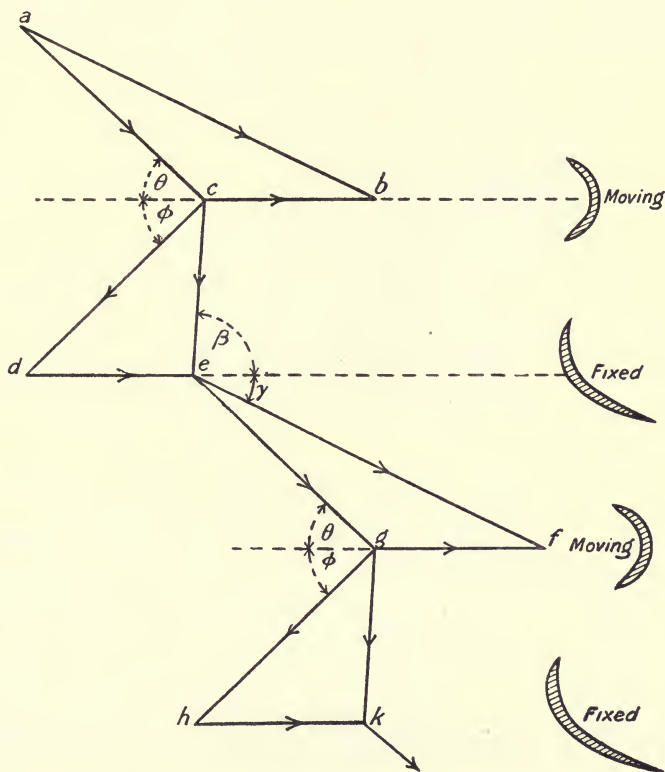

FIG. 96.—Velocity diagram for the Rateau turbine.

of the De Laval type; *ab* represents the absolute velocity of the steam leaving the first set of fixed vanes or nozzles, *cb* the velocity of the tips of the first set of moving blades, and *ac* the velocity of the steam relative to the moving blades. The angle (θ) of the blades at inlet must therefore be parallel to *ac*, in order that the steam may enter them without shock. The velocity of the steam relative to the moving blades at exit is represented by *cd*, and the absolute velocity leaving the moving blades by *ce*, ϕ being the angle of the moving blades at exit.

The steam leaving the first set of moving blades with absolute velocity *ce* next impinges on the second set of fixed blades, and is guided by them in the direction *ef*, the fall of pressure being such that the absolute velocity *ef* entering the second set of moving blades is the same as *ab*. The same

¹ See *Proc. Inst. Mech. Eng.*, June, 1904, p. 737.

action is now repeated, and efg is the triangle of velocities at entrance to the second set of moving blades, and ghk the triangle of velocities at exit. The entrance angle of the second set of fixed blades is β , the exit angle being γ .

114. Turbines with one or more Stages, each compounded for Velocity.—The Curtis turbine is the best known example of this type, a diagrammatic sketch of the arrangement of nozzles and blades being shown in Fig. 97. In the example illustrated two stages are shown, in each

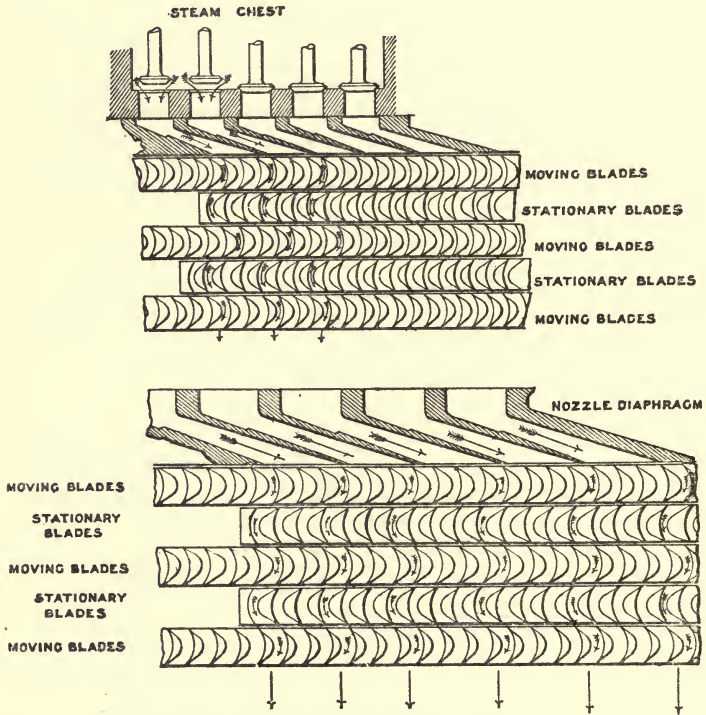

FIG. 97.—Arrangement of nozzles and blades of Curtis turbine.

of which there are one ring of nozzles, three rings of moving and two rings of stationary blades. The velocity diagram for one stage is shown in Fig. 98. Using the same notation as before, θ and ϕ denote the angles of the moving blades at entrance and exit respectively, whilst β and γ denote the corresponding angles for the fixed blades. Fig. 98 has been drawn on the assumption that the relative velocity of the steam at entrance and exit of each ring of blades is the same, *i.e.* $r = R$ (see Art. 112), and also that the velocity of the tips of all the moving blades is equal, *i.e.*

$$cb = dc = gf = hk = ml$$

If the absolute velocity of the steam entering the first set of moving blades be denoted by V , and the absolute velocity on leaving the last set

of moving blades* by v , then, as in Art. 112, the efficiency of the stage will be (neglecting losses)

$$\frac{V^2 - v^2}{V^2}$$

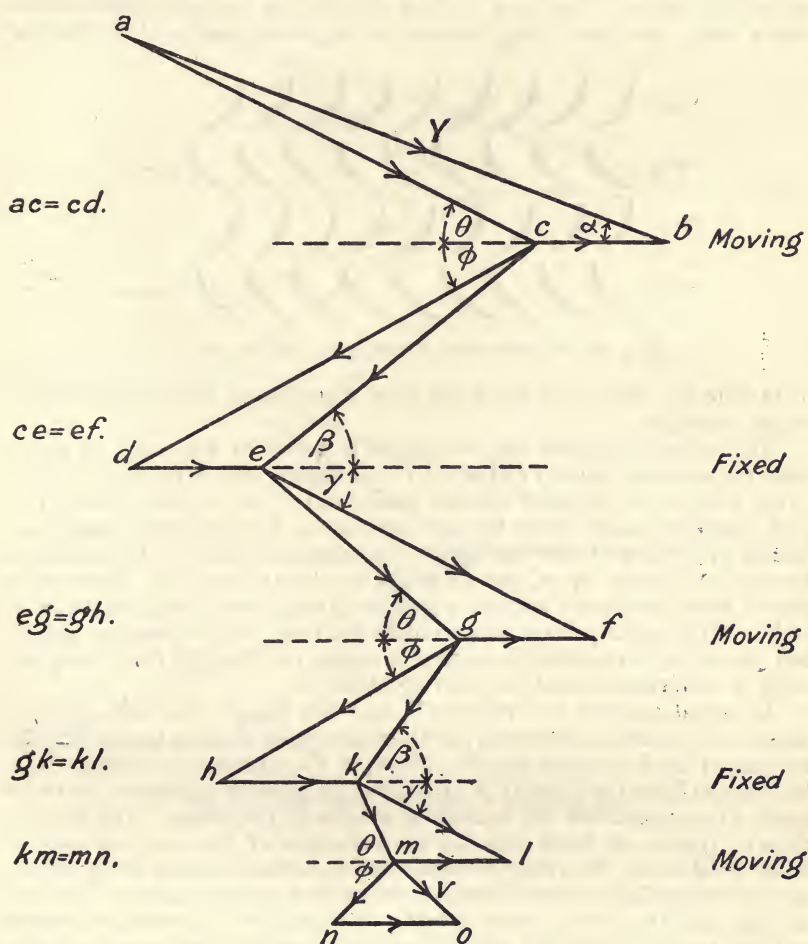

FIG. 98.—Velocity diagram for one stage of Curtis turbine.

115. Multi-Stage Reaction Turbines—The Parsons Turbine.¹—Although commonly called a reaction turbine, this turbine works partly by impulse and partly by reaction. The arrangement of blading is shown diagrammatically in Fig. 99. The steam expands through the first ring of fixed blades, from which it is directed on to a ring of moving blades,

¹ For a detailed description of this and other types of turbines see "The Steam Turbine," by R. N. Neilson. Longmans.

then through another ring of fixed blades and another of moving blades, and so on alternately right along from the high-pressure to the exhaust end of the turbine. Kinetic energy is developed in the fixed blades and also in the moving blades whilst energy is being taken up by them from the expanding steam. Each pair of fixed and moving rings of blades constitute a stage, and since a large number of stages are employed in this type



FIG. 99.—Arrangement of blading for Parsons turbine.

of turbine the velocity of the steam (and therefore of the moving blades) is not very high.

The velocity diagram for two stages is shown in Fig. 100; ab represents the absolute velocity (V) of the steam leaving one of the fixed blades, cb the velocity of the next moving blade, and ac the relative velocity (R) with which the steam enters the moving blades. The expansion being continued in the ring of moving blades the relative velocity of the steam on leaving (r) is given by cd , and its absolute velocity (v) by ce . In the next ring of fixed blades the velocity is increased to ef , which is the same as ab or V . With velocity V the steam enters the next ring of moving blades, and the action is repeated in successive stages, the pressure drop being the same in each ring of fixed and moving blades.

In actual practice the velocity V does not remain the same in each stage, but increases continuously as the steam flows through the turbine, on account of the increasing specific volume of the steam as its pressure falls. In order to keep the velocity V as uniform as possible provision has to be made to accommodate the increasing volume of the steam. The moving rings of blades are fixed into the circumference of the rotor and project radially outwards. The rings of fixed blades are fixed into the outer casing, and project radially inwards between the rings of moving blades. The area through which the steam passes is that of the annular ring between the rotor and outer casing, minus the area of cross section of the blades, and in order to increase this area the length of the blade is increased at certain points along the length of the rotor and casing, the diameter increasing in steps towards the exhaust end, the lengths of the blades in the several rings of blades in each step being the same.

The angle of the blades at exit is of very great importance. Referring to Fig. 100, it will be seen that the smaller the exit angle from the fixed blades (γ), the greater will be the velocity of the steam (V) as it leaves; also, the smaller the exit angle of the moving blades (ϕ), the smaller is the absolute velocity of the steam (v) leaving them, and consequently the less is the kinetic energy remaining in the steam as it leaves the moving blades.

It would appear, therefore, that the smaller these angles are made the better, but a limit is imposed by practical considerations. The smaller the angle the less is the width ab (Fig. 101) of the steam passage between adjacent

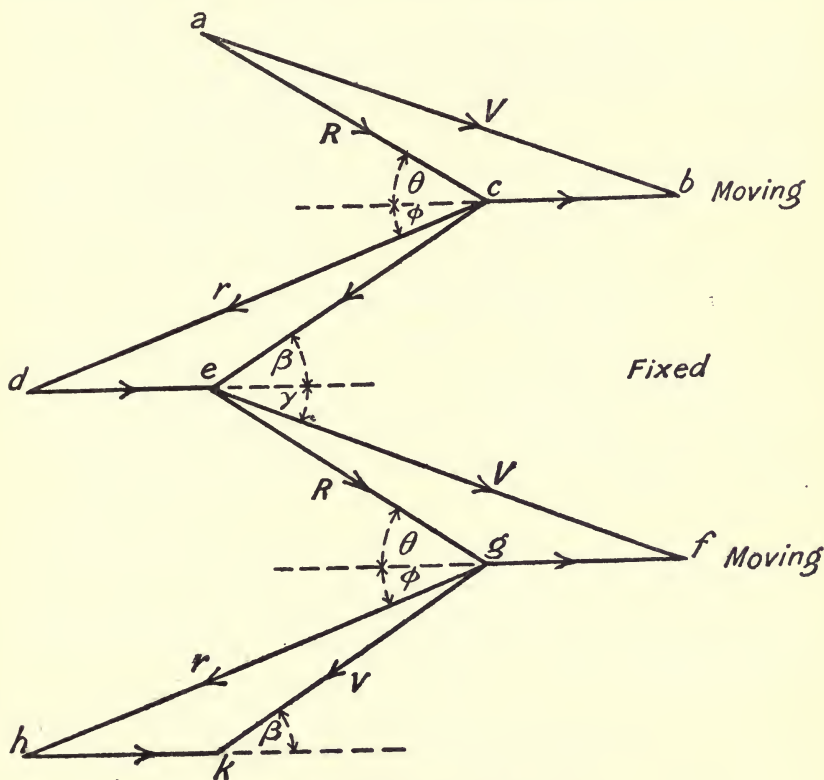

FIG. 100.—Velocity diagram for Parsons turbine.

blades which makes the thickness of the blade t greater in proportion to ab , resulting in an increased tendency to form eddies and a consequent reduction in the available energy of the steam. In addition, very small exit angles have the defect of increasing the length of the blade passages, and therefore the frictional resistance.

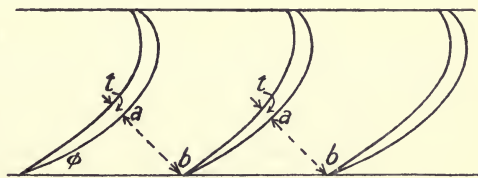

FIG. 101.

In turbines of this type it is usual to make the exit angle about 20° and to make the moving and fixed blades exactly alike. At the low-pressure end of the turbine, the exit angles of the last few rings of blades is generally

increased in order to provide for an increase in the steam area without the use of excessively long blades. Such blades are called "semi-wing" or "full-wing," depending upon the outlet angle.¹

EXAMPLE 1.—The steam chest pressure in a De Laval turbine is 200 pounds per square inch absolute, and the exhaust pressure 5 pounds per square inch absolute, the steam being initially dry and saturated. The peripheral speed of the blades is 1200 feet per second, and the nozzle is inclined 20° to the direction of motion of the blades. Estimate the angles of the blades, the work done on the blades per second per pound of steam, the absolute velocity of the steam at discharge from the blades, and the efficiency of the turbine. Neglect frictional resistances and assume adiabatic flow.

From the Mollier Diagram we find the heat drop in the nozzle to be 253 B.Th.U. and the velocity at entrance to the wheel

$$\sqrt{778 \times 253 \times 64.4} = 3560 \text{ feet per second}$$

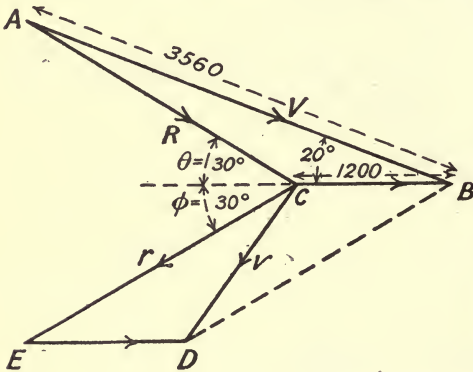

FIG. 102.

The velocity diagram is shown in Fig. 102. On setting this out to scale, θ is found to be 30°, and $AC = 2470$ feet per second. The De Laval blades are made symmetrical with equal inlet and outlet angles, hence, making $\theta = \phi$ and $CE = AC$, the absolute velocity at discharge is found to be 1530 feet per second.

The work done per second per pound of steam is by (3), Art. 110,

$$\begin{aligned} U &= \frac{1200}{32.2} (2470 \cos 30^\circ + 2470 \cos 30^\circ) \\ &= \frac{2400 \times 2470 \times 0.866}{32.2} \\ &= 159,400 \text{ foot-pounds} \end{aligned}$$

The efficiency will be

$$\frac{(3560)^2 - (1530)^2}{(3560)^2} = 0.815$$

The value of the inlet and outlet angles and the absolute velocity at discharge may be obtained by calculation as follows:—

$$\begin{aligned} R^2 &= (1200)^2 + (3560)^2 - 2 \times 1200 \times 3560 \cos 20^\circ \\ &= 10^6(1.44 + 12.6736 - 8.0288) \\ &= 10^6 \times 6.0848 \end{aligned}$$

$\therefore R = 2466$ feet per second, which agrees with the result found above.

¹ For a detailed discussion of blade angles see "Steam Turbine Design," by J. Morrow. Edward Arnold.

Also

$$\frac{\sin \theta}{3560} = \frac{\sin 20^\circ}{2466}$$

$$\sin \theta = \frac{0.342 \times 3560}{2466} = 0.4935$$

$$\therefore \theta = \sin^{-1} 0.4935 = 29.6^\circ$$

and

$$v^2 = (1200)^2 + (2466)^2 - 2 \times 1200 \times 2466 \cos 29.6^\circ$$

$$= 10^6(1.44 + 6.0848 - 5.1486)$$

$$= 10^6 \times 2.3562$$

$$\therefore v = 1535 \text{ feet per second as above}$$

EXAMPLE 2.—If the steam consumption of the above turbine is 3600 pounds per hour, estimate the horse-power of the turbine.

From the above Example 1, the work done per second is

$$\frac{3600}{60 \times 60} \times 159,400 \text{ foot-pounds}$$

$$\text{and the horse-power} = \frac{159,400}{550} = 290 \text{ H.P.}$$

EXAMPLE 3.—In the turbine given in Example 1, find the blade angles work done per second per pound of steam, the speed of the wheel, and the efficiency, if the efficiency is to be the greatest possible.

This is an example on Case 1, Art. 112. Here $\alpha = 20^\circ$, $V = 3560$ feet per second, and $\theta = \phi$.

$$\text{By (4), Art. 112, } V_b = \frac{3560}{2} \cos 20^\circ$$

$$= 1780 \times 0.9397$$

$$= 1673 \text{ feet per second}$$

$$\text{By (5), Art. 112, } \tan \theta = 2 \tan 20^\circ$$

$$= 2 \times 0.364$$

$$= 0.728$$

$$\therefore \theta = \tan^{-1} 0.728 = 36^\circ \text{ nearly}$$

$$\text{By (7), Art. 112, } U = \frac{1}{2} \times \frac{(3560 \times 0.9397)^2}{32.2}$$

$$= 173,800 \text{ foot-pounds}$$

$$\text{By (10), Art. 112, the efficiency} = (\cos 20^\circ)^2$$

$$= (0.9397)^2$$

$$= 0.883$$

EXAMPLE 4.—An impulse turbine of the Curtis type has two stages with one set of nozzles and three rotating and two stationary sets of blades. Superheated steam is expanded adiabatically in the first set of nozzles from a pressure of 180 pounds per square inch absolute and temperature 473°F. to 24 pounds per square inch absolute. The nozzles are inclined at an angle of 20° to the plane of rotation of the running blades, which have a peripheral speed of 450 feet per second. Determine the angles of the three moving and two stationary sets of blades in the first stage, and give the absolute velocity of the steam as it leaves the last set of running blades.

Referring to steam tables (p. 480), we find that the temperature of saturation at 180 pounds absolute is 373°F. Hence, the steam is superheated, $473 - 373 = 100^\circ \text{F.}$

By means of the Mollier Diagram, the velocity of the steam issuing from the nozzles is found to be 2840 feet per second.

The velocity diagram has been drawn for three different conditions, in

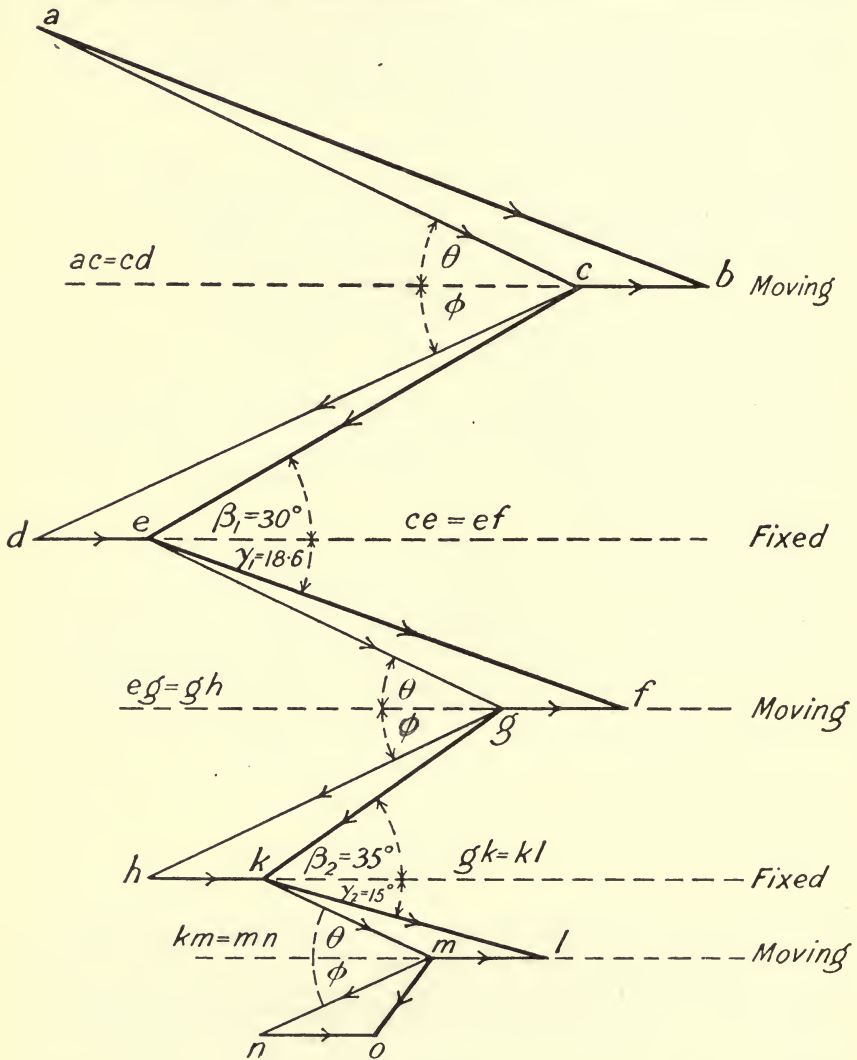

FIG. 103.

each of which the effect of friction has been neglected. In the first case taken (Fig. 103), the moving blades have all been made symmetrical, the inlet and outlet angles being the same for each ring. In Fig. 103, which is self-explanatory, the angle at inlet (θ) has been made equal to the angle

at exit (ϕ), and all the absolute velocities are represented by means of a thick line. The results obtained are as follows:—

Moving blades	$\theta = \phi = 24^\circ$ for each ring.	
	1st ring.	2nd ring.
Fixed blades . .	Inlet angle $\beta_1 = 30^\circ$ Outlet angle $\gamma_1 = 18.6^\circ$	Inlet angle $\beta_2 = 35^\circ$ Outlet angle $\beta_2 = 15^\circ$

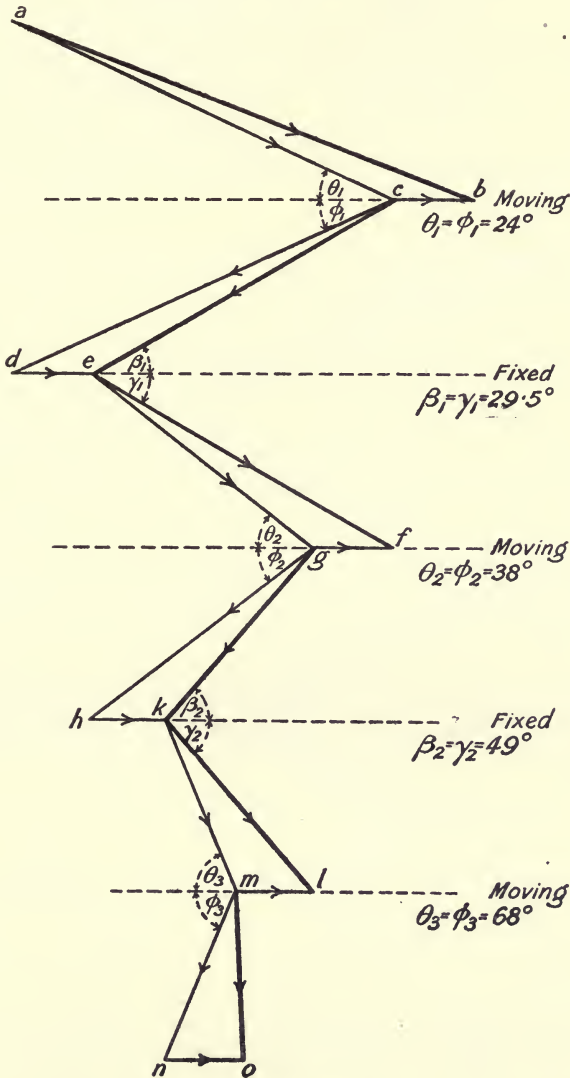

FIG. 104.

The absolute velocity of the steam leaving the last ring of moving blades is $m_o = 375$ feet per second.

Second Case.—In this case θ has been made equal to ϕ in the same ring of moving blades, and β equal to γ in the same ring of fixed blades, but the angles in one ring differ from those in another (see Fig. 104). The results obtained are—

	1st ring.	2nd ring.	3rd ring.
Moving blades . . .	$\theta_1 = \phi_1 = 24^\circ$	$\theta_2 = \phi_2 = 38^\circ$	$\theta_3 = \phi_3 = 68^\circ$
Fixed blades . . .	$\beta_1 = \gamma_1 = 29.5^\circ$	$\beta_2 = \gamma_2 = 49^\circ$	

The absolute velocity of the steam leaving the last ring of moving blades is $m_o = 1000$ feet per second.

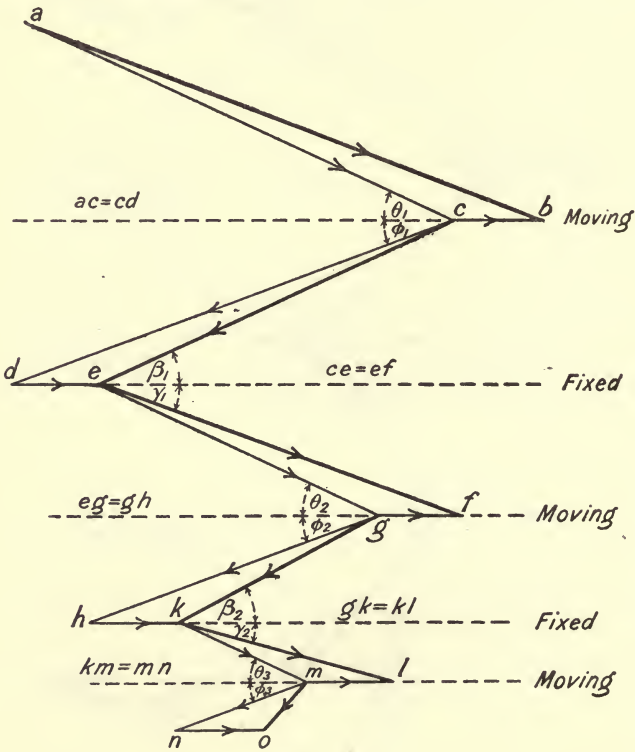

FIG. 105.

Third Case.—In this case θ and ϕ have been made the same for all rings of moving blades, but θ is not equal to ϕ , i.e. the blades in the three rings of moving blades are symmetrical, but the entrance and exit angles are different. The magnitude of the outlet angle ϕ has been fixed at 20° ,

and the velocity diagram drawn accordingly (see Fig. 105). The results obtained are :—

	1st ring.	2nd ring.	3rd ring.
Moving blades . .	Inlet angle $\theta_1 = 24^\circ$ Outlet angle $\phi_1 = 20^\circ$	$\theta_2 = 24^\circ$ $\phi_2 = 20^\circ$	$\theta_3 = 24^\circ$ $\phi_3 = 20^\circ$
Fixed blades . .	Inlet angle $\beta_1 = 24^\circ$ Outlet angle $\gamma_1 = 19^\circ$	$\beta_2 = 27.5^\circ$ $\gamma_2 = 24^\circ$	— —

The absolute velocity of the steam leaving the last ring of moving blades is $m_0 = 340$ feet per second.

116. Losses in Steam Turbines.—The chief losses which occur may be divided into those produced by—

- (a) Steam leakage.
- (b) Heat leakage.
- (c) Frictional resistance.

(a) **Steam Leakage.**—In all types of steam turbines some of the steam leaks past the tips of the moving blades without doing work on them. The proportion of available energy of this leakage steam, which is wholly lost, depends upon the type of turbine. In the De Laval turbine the available energy in the amount of steam which does not enter the moving blades is practically lost, since it passes directly from the nozzle into the turbine casing without doing useful work.

In the Rateau and Zoelly turbines (Art. 113) each running wheel is mounted in a separate compartment, and any steam that leaks out between any ring of nozzles and the next set of rotating blades is enclosed in a separate chamber and its kinetic energy is there converted back into heat energy, which may be utilised again in the next stage. Also, since the kinetic energy of this leakage steam is only a comparatively small fraction of its total available energy (there being a large number of stages), the total loss due to leakage is comparatively small in spite of the large number of stages.

In the case of the Curtis turbine (Art. 114), steam, on leaving the nozzle, may leak past the first set of moving blades, but (unlike the de Laval turbine) all its kinetic energy is not lost, because, since it passes through the remaining rings of fixed and moving blades at constant pressure, some of the kinetic energy is available for extraction by the moving blades, and although some leakage may occur between adjacent rings of fixed and moving blades, the net loss is less than if these rings were absent.

The facilities for leakage are very much greater in the Parsons turbine. Unlike the Rateau and Zoelly turbines, all the rings of moving blades are fixed on a common spindle running in one chamber between rows of fixed blades, and, further, there is a continuous expansion and fall of pressure along the turbine (Art. 115). The difference of pressure on the two sides of each ring of moving blades increases the tendency to leakage, particularly at the high-pressure end of the turbine, since at this end of the turbine the necessary height of the blades is small because of the high density of the steam and the leakage area, *i.e.* the annular ring between the tips of the moving blades and the outer casing which is necessary for clearance,

is a greater proportion of the total area through the blades than at the low-pressure end where the blade height is much greater.

(b) **Heat Leakage.**—One of the advantages possessed by a turbine over a reciprocating engine consists in the absence of initial condensation when once the turbine has settled down into working conditions. In the case of the Parsons turbine, for example, at any point on the length of the rotor the temperature remains constant. There will, however, be a steady flow of heat from the high-pressure towards the low-pressure end. The amount of heat which thus leaks through to the exhaust does not all represent a dead loss, because part of it is available for drying the steam, and thereby reducing the frictional resistance between the moving blades and the steam. In addition to this leakage there will be the loss due to radiation and conduction by the metallic casing. The general effect of heat leakage on the efficiency of the turbine is best seen with reference to the temperature-entropy diagram.

The diagram with no heat loss is represented by $abcd$ in Fig. 106, this

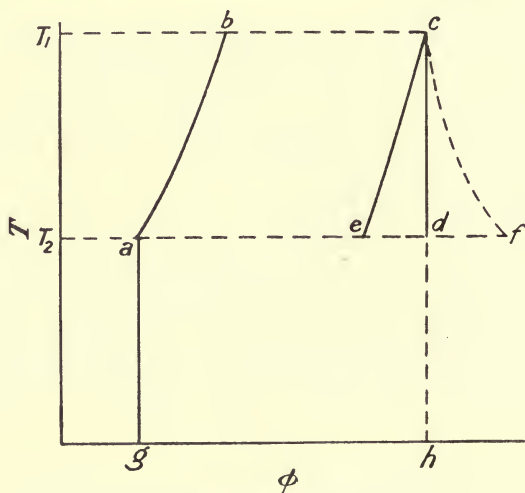

FIG. 106.—Effect of heat leakage.

being the diagram for the Rankine cycle already considered (Art. 57). If the steam loses heat throughout the expansion the final dryness fraction will be less than if the expansion were adiabatic, and the expansion line will terminate at some point e on the left of d , such that $\frac{ae}{af}$ represents the final dryness fraction. Some of the steam will therefore be condensed at temperatures varying from T_1 to T_2 , and assuming the loss of entropy during expansion to be proportional to the fall of temperature the expansion line will be represented by ce instead of the adiabatic cd . The temperature entropy diagram with heat leakage is therefore represented by $abce$, this area representing the amount of heat converted into work, whilst the area ced represents the loss due to heat leakage.

The heat supplied is denoted by the area $gabch$ and the overall efficiency of the turbine will be

$$\frac{\text{Area } abce}{\text{Area } gabch}$$

(c) **Frictional Resistance.**—Of the frictional resistance in a steam turbine, mechanical friction at the bearings is usually very small, the principal resistances being those between the steam and the blades. The effect of friction on the flow of steam through the fixed nozzles has already been discussed in Art. 107. The effect in the moving blades is to make the relative velocity at exit less than at entrance to the blades ($r = kR$), and its effect on the efficiency of the blades has been dealt with in Art. 112. The other losses which occur are due to the frictional resistance offered to the rotation of the turbine wheel or wheels in the steam, and the loss due to shock at entrance to the moving blades.

The frictional resistance between the running wheel or wheels and the steam may in some cases be very great. Its magnitude depends upon the density of the steam in which the wheel rotates, upon the quality of the steam and upon the speed of the wheel. From results of tests carried out on De Laval turbines it appears that for a given speed of wheel and quality of steam the frictional resistance is proportional to the density of the steam. If dry saturated steam be used it will be wet after expansion, and the presence of this moisture will greatly increase the friction. The greater economy which results from the use of superheated steam is doubtless due to the reduced frictional resistance resulting from the absence of water in the steam. For a given quality and pressure of steam the resistance increases rapidly with increasing speed; with wheels of the De Laval type the frictional loss appears to be proportional to about the cube of the speed,¹ and the fifth power of the diameter, *i.e.* the wheel friction for this type is proportional to $d^5 n^3$, where d is the diameter of the wheel and n the number of revolutions per minute.

Now the velocity of the blades V is proportional to $d \times n$, therefore the frictional loss is proportional to $d^2 \times V^3$, and the resisting torque due to wheel friction is proportional to dV^3 . In other words, the resisting torque for a given speed is proportional to the diameter of the wheel, or for a given wheel is proportional to V^3 . At the lower speeds used in the Curtis turbine, however, the frictional resisting torque is found to be approximately proportional to the velocity of the blades.

The total resisting torque, *i.e.* that due to frictional resistance between the running wheel and the steam and also that due to mechanical friction at the bearings, may be conveniently measured as follows:—

With the machine running light, *i.e.* with no load, shut off steam and measure the time (t_0) taken for the speed to fall from n_1 to n_2 . The angular retardation will evidently be

$$\frac{n_1 - n_2}{t_0}$$

Next run the machine at the normal speed n_1 on a *known* external

¹ Mr. K. Anderson, in *Transactions* of the Inst. of Engineers and Shipbuilders in Scotland, vol. xlvi, part iv.

load, shut off steam and observe the time (t) taken for the speed to fall again to the same value n_2 as before. The angular retardation in this case will be

$$\frac{n_1 - n_2}{t}$$

Let T_0 be the resisting torque, T the torque corresponding to the known load on the shaft, and I the moment of inertia of the rotating parts, then

$$T_0 = I \cdot \frac{n_1 - n_2}{t_0} \dots \dots \dots (1)$$

and $T + T_0 = I \cdot \frac{n_1 - n_2}{t} \dots \dots \dots (2)$

(1) in (2) gives

$$T + T_0 = T_0 \cdot \frac{t_0}{n_1 - n_2} \cdot \frac{n_1 - n_2}{t}$$

$$T + T_0 = T_0 \cdot \frac{t_0}{t}$$

$$\therefore T_0 = \frac{T \cdot t}{t_0 - t} \dots \dots \dots (3)$$

The mean speed during the test is $\frac{n_1 + n_2}{2}$, and if the known brake horse-power is H , and n_1 and n_2 are in revolutions per minute

$$T \times 2\pi \cdot \frac{n_1 + n_2}{2} = H \times 33,000$$

$$\therefore T = H \cdot \frac{33,000}{\pi(n_1 + n_2)} \text{ pound-feet} \dots (4)$$

Loss due to Shock.—The condition for no shock is that the direction of motion of the steam relative to the blades must be parallel to the blades at entrance (see Art. 113, p. 195). Even when the speed of the blades and the angle at entrance fulfil this condition, some shock must take place because the blades must have an appreciable thickness, and some of the steam striking the inlet edge of the blades makes it impossible to altogether eliminate loss from this cause. The general effect of shock is the same as that of friction, since some of the energy lost is returned to the steam as heat.

117. Effect of Pressure on Efficiency.—In the case of a reciprocating engine a high initial steam pressure is beneficial in reducing the steam consumption; but in the case of a steam turbine any increase of the initial pressure above a certain value (about 180 pounds per square inch) has very little effect on the steam consumption. In the Parsons type of turbine the necessary blade length is small at the high-pressure end of the turbine, and (as already mentioned in Art. 116) the leakage area is a greater proportion of the blade length than at any other point in the turbine. This, in conjunction with the high density of the steam, results in a greater weight of steam leaking past the blades at the high-pressure end without doing useful work.

As the pressure falls along the turbine the blade length increases, but

the ratio of leakage area to blade length *decreases*; the density of the steam also decreases with fall of pressure. The tendency to leakage is therefore less at the low-pressure than at the high-pressure end of the turbine, and so also is the frictional resistance between the running blades and the steam. It is evident, therefore, that in this type of turbine the steam is more usefully employed in the low-pressure portion than in the high-pressure portion. Many Parsons turbines have a lower steam consumption than a good modern reciprocating engine using steam of the same initial pressure and quality; the high-pressure end of the turbine is of lower efficiency than the corresponding portion of the reciprocating engine, but since the expansion is continued very nearly down to the condenser pressure, the very much greater efficiency of the low-pressure portion of the former results in a net gain.

In the case of the De Laval turbine with a given exhaust pressure, an increase in the initial steam pressure (above a certain value) will increase the velocity of the steam issuing from the nozzle. This will increase the frictional resistance in the nozzle and reduce its efficiency, will increase the wetness of the steam and greatly increase the frictional resistance between the running wheel and the steam. These increased losses will more or less balance the extra amount of work got out of the turbine, with the result that the steam consumption will be very little reduced.

118. Effect of Superheat on Efficiency.—The increased efficiency obtained by using superheated steam in a turbine is very much greater than thermodynamic reasons would imply (see Art. 58), as is also the case with the reciprocating engine, but the way in which this common result is obtained is not the same in both machines. The increased economy of the reciprocating engine is due largely to the reduction in the initial condensation and also very probably to a reduction in valve leakage (Art. 77).

In the case of the turbine, initial condensation is a minor item, being in most cases non-existent, since there is very little, if any, variation in temperature at any point in the turbine after it has settled down into working conditions. Superheated steam increases the efficiency of a turbine by reducing the fluid friction. The fluid friction will be reduced because there will be less moisture in the steam than if it were originally dry saturated. In the Parsons type of turbine the percentage leakage of steam will only depend upon the ratio of clearance to blade height, and will therefore be the same whatever the condition of the steam, *i.e.* whether superheated or saturated, because, although with superheated steam the actual weight of leakage steam will be less on account of its lower density, the total weight will also be less, and the ratio of the two will remain constant. The efficiency of the Parsons turbine is found to increase about 1 per cent. for every 10° F. of initial superheat.

119. Effect of Vacuum on Efficiency.—As mentioned in Art. 117, the steam leakage in a turbine of the Parsons type decreases as the pressure falls, and the turbine can continue to extract work from the steam at a very much lower pressure than is possible in a reciprocating engine. For this reason a steam turbine approximates more closely to the Rankine cycle than does a reciprocating engine, inasmuch as the expansion is more complete and continues right down to the condenser pressure. In a reciprocating engine the expansion is rarely carried down to a pressure

below about 8 pounds per square inch absolute for two main reasons, namely, on account of engine friction (Art. 75), and also because of the large low-pressure cylinder that would be required in order to accommodate the large volume of the steam at a very low pressure, which in its turn would increase the engine friction and more than counterbalance the increased amount of indicated work obtained in the engine cylinder.

This extra amount of useful work that may be obtained in a turbine by continuing the expansion down to condenser pressure is best shown on the temperature-entropy diagram. Fig. 107 is drawn for an initial

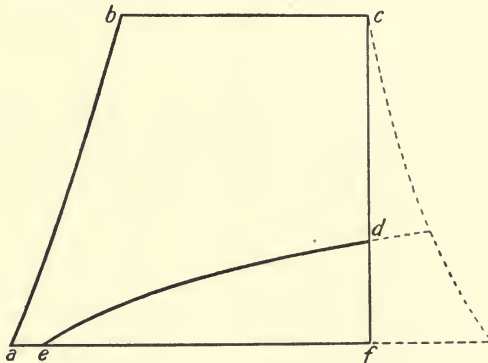

FIG. 107.

pressure of 200 pounds per square inch absolute, and a condenser pressure of 0.5 pound absolute, corresponding to a vacuum of 29 inches of mercury. Taking a release pressure of 8 pounds absolute in the reciprocating engine, the area $abcde$ represents the amount of work theoretically possible per pound of steam with the same condenser pressure of 0.5 pound absolute, whilst the area $abcf$ represents the amount of work possible in a turbine with complete expansion. The area def represents the gain due to complete expansion in the turbine. In the ideal case considered this will be found to be 82.3 B.Th.U. or 64,000 foot-pounds per pound of steam. A turbine, however, cannot follow the ideal Rankine cycle, so that the actual saving obtained will be less than this amount. Increasing the condenser pressure will reduce the efficiency of a turbine much more than a reciprocating engine, as will be evident from an inspection of Fig. 107, since by raising the line af the latter is only affected along the short length ae , whilst the turbine is affected over the length af .

From the results of many tests carried out in practice it appears that with ordinary boiler pressures (about 180 to 200 pounds absolute) a reduction of condenser pressure from 2.5 pounds absolute, *i.e.* a vacuum of 25 inches, to 1 pound absolute, *i.e.* a vacuum of 28 inches, increases the efficiency by about 13 per cent. The effect on steam consumption of increasing the vacuum in a Westinghouse-Parsons turbine is very clearly shown in Fig. 108, which shows the results of actual tests carried out on a 1250 kw. turbine.¹

¹ From a paper by Mr. F. Hodgkinson, *Proc. I. Mech. E.*, June, 1904, p. 653.

From what has been said above it is evident that in order to obtain the best results from a turbine the condenser pressure should be kept as

Lbs. steam per brake horse-power hour.

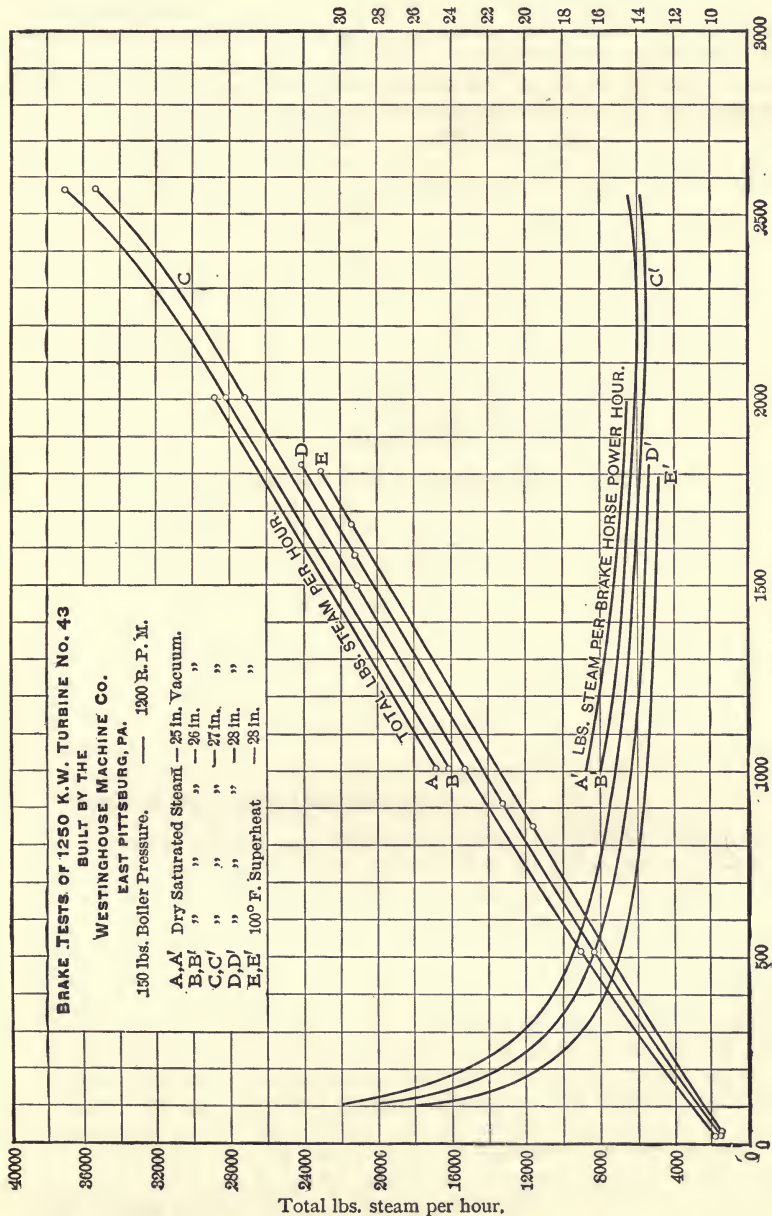

Brake Horse Power.
 FIG. 108.

low as possible. The greatest possible vacuum, however, is not necessarily the most economical, because a limit will be reached at which the rate of increase of the cost of maintaining the vacuum will be greater than the rate of increase of the power produced.

EXAMPLE.—Dry saturated steam expands from an initial pressure of 200 pounds per square inch absolute down to a condenser pressure of 1 pound per square inch absolute. Find the maximum amount of work possible per pound of steam. With the same initial pressure, what would be the pressure after complete expansion in order that the work done may be half as much as the previous case.

Using equation (4), Art. 101, we have

$$\text{Work done} = \frac{n}{n-1} \cdot p_1 v_1 \left\{ 1 - \left(\frac{p_2}{p_1} \right)^{\frac{n-1}{n}} \right\}$$

From steam tables we find $v_1 = 2.29$ cubic feet, and taking $n = 1.135$

$$\begin{aligned} \text{Work done} &= \frac{1.135}{0.135} \times 200 \times 144 \times 2.29 \left\{ 1 - \left(\frac{1}{200} \right)^{0.135} \right\} \\ &= 554,600 \{ 1 - 0.5326 \} \\ &= 554,600 \times 0.4674 \\ &= 259,200 \text{ foot-pounds} \end{aligned}$$

Let p be the pressure after expansion in the second case, then

$$\begin{aligned} \frac{1.135}{0.135} \times 200 \times 144 \times 2.29 \left\{ 1 - \left(\frac{p}{200} \right)^{0.135} \right\} &= \frac{259,200}{2} \\ 554,600 \left\{ 1 - \left(\frac{p}{200} \right)^{0.135} \right\} &= 129,600 \\ 1 - \left(\frac{p}{200} \right)^{0.135} &= \frac{129,600}{554,600} = 0.2336 \\ \therefore \frac{p}{200} &= (0.7664)^{0.135} = 0.1067 \\ \therefore p &= 200 \times 0.1067 \\ &= 21.34 \text{ pounds per square inch absolute} \end{aligned}$$

A reciprocating engine working between 200 pounds absolute and 21 pounds absolute would be able to utilise as much, if not more, of the available energy of 1 pound of steam, *i.e.* of 129,600 foot-pounds, than would a turbine working between the same pressures. It is in the latter half of the expansion, from 21 pounds to 1 pound absolute, where the possibilities of the turbine are so marked, since, as already mentioned, the reciprocating engine could not utilise as much of the available energy (129,600 foot-pounds) as the turbine.

120. Exhaust Steam Turbines.—In order to utilise the exhaust steam from either condensing or non-condensing reciprocating engines, low-pressure turbines are frequently used to recover a lot of the available energy which would otherwise be lost through incomplete expansion. One of the most interesting applications of steam turbines is the employment of exhaust steam from engines working intermittently, as is the case with colliery winding engines and engines driving rolling mills

and the like. Professor Rateau has given special attention to this problem, and has obtained satisfactory results by employing his regenerative accumulator, which regulates the intermittent flow of steam before it passes to low-pressure turbines.¹

The application of steam turbines to marine practice presents a feature which is usually absent in land practice. To obtain the required low speed of the propeller shaft without using gearing is a matter which requires careful consideration. In marine turbines of the Parsons type the necessary vane speed (about half the speed of the steam, see Art. 112) is obtained either by increasing the number of stages or by increasing the diameter of the turbine, or by both of these means. The number of stages is limited by the length of engine-room available, and the greatest diameter permissible is again fixed by the size of engine-room. With a given number of stages the speed of revolution may be reduced without altering the blade speed by increasing the diameter of the blade rings. For a given radial clearance, however, this increases the leakage area for steam, and for the same area of passage, *i.e.* for the same power, the required blade length would be smaller for larger than for smaller diameters, so that the ratio of leakage area to blade length would increase with increase of diameter. The suitable diameter for a given power is therefore limited. For slow-speed vessels, if turbines are to be used alone, gearing must usually be employed and the turbines run at a higher speed.

A combination system of reciprocating engines and turbines appears to be suitable for large steamships designed to run at a moderate speed.² In such a system, the reciprocating engines (running at a moderate speed) are supplied with the high-pressure steam, the exhaust from them being utilised by low-pressure turbines which can be run at the low speed required without being of excessive length or diameter.

121. Governing of Steam Turbines.—The majority of steam turbines are governed by throttling the steam at the main admission valve. In the De Laval turbine, wide variations in load are allowed for by varying the number of nozzles in use, usually by hand, but sometimes automatically but small variations of a given load are met by throttling the steam at admissions without altering the number of nozzles in use, the governor used being of the centrifugal type.

In the Rateau turbine the method of governing depends upon the increase or decrease in the speed above or below the normal. A small increase or decrease of speed from the normal speed of the turbine is met by the centrifugal governor throttling the steam at the admission valve. A greater *decrease* of speed causes the governor, in addition to acting on the admission valve, to open a valve and admit high-pressure steam to an intermediate part of the turbine, and so allow an overload to be maintained. A greater *increase* of speed causes the governor to vary the number of steam passages in the first ring of fixed blades, to which steam is admitted whilst still acting on the admission valve.

The Zoelly turbine is governed by throttling at the admission valve, but in order to allow for overload high-pressure steam is also admitted

¹ For a description of this apparatus see *Proc. I. Mech. E.*, 1904, Part 3, p. 771; also *Proc. I. Mech. E.*, 1901, Part 4, p. 945.

² See a paper by the Hon. C. A. Parsons and Mr. R. J. Walker, *Trans. Inst. Nav. Arch.*, April, 1908.

direct to the second or third stage nozzles. An additional emergency governor is also supplied, which shuts off all steam to the turbine in the event of the speed exceeding the normal speed by about 10 per cent.

The Curtis turbine is governed by varying the number of high-pressure nozzles in the first stage to which steam is admitted. The governor controls the opening and closing of the valves to these nozzles, but the valves themselves are actuated either electrically or from the turbine shaft, or by other means.

In the Parsons turbine the steam is supplied through the admission valve in a series of gusts, the number of gusts per minute being varied from about 100 to 400 to suit the load on the turbine, by means of a relay governor, which may be of the centrifugal or electrical type. An emergency governor is also fitted, which shuts off steam if the speed should rise about 10 per cent. above the normal speed of the turbine. To meet an overload on the turbine, steam is also admitted to an intermediate point in the turbine through a bye-pass valve. In the Willans-Parsons turbine the governing is done by throttling instead of by gusts.

EXAMPLES IX.

1. The steam chest pressure in a De Laval turbine is 140 pounds per square inch absolute, and the exhaust pressure 3 pounds per square inch absolute, the steam being initially dry and saturated. The peripheral speed of the blades is 1200 feet per second, and the nozzles are inclined 20° to the direction of motion of the blades. Estimate the angle of the blades, the work done on the blades per second per pound of steam, the absolute velocity of the steam at discharge from the blades and the efficiency of the blades. Neglect frictional losses and assume adiabatic flow.

2. In the turbine given in Example 1 find the blade angles, work done per pound of steam per second, the speed of the blades, and the efficiency if the efficiency is to be the greatest possible. Neglect all losses.

3. Steam of initial pressure 140 pounds per square inch absolute and with 160° F. of superheat is supplied to a De Laval turbine whose exhaust pressure is 3 pounds per square inch absolute; the nozzles are inclined 20° to the direction of motion of the blades and the peripheral speed of the blades is 1200 feet per second. Estimate the angle of the blades, the efficiency of the blades, and the horse-power developed if the steam consumption is 1800 pounds per hour.

4. Solve Problem 1, if the effect of friction is such that the relative velocity of the steam at exit from the blades is 0.9 of the velocity at inlet (*i.e.* a velocity coefficient of 0.9).

5. An impulse turbine of the Curtis type has two stages with one set of nozzles and three rotating and two stationary sets of blades. Dry saturated steam is expanded in the first set of nozzles from a pressure of 200 pounds per square inch absolute to 40 pounds absolute. The nozzles are inclined 20° to the direction of motion of the running blades, which have a speed of 500 feet per second. Determine the angles of the three moving and two stationary sets of blades in the first stage, and give the absolute velocity of the steam as it leaves the last set of running blades. Make the inlet and exit angles of all the moving blades the same in each ring.

6. In one stage of a Curtis turbine steam issues from the nozzles with a velocity of 2500 feet per second. There are two moving rings and one fixed ring of blades in the stage, and the mean peripheral speed of the blades is 500 feet per second. The exit angles are as follows: From nozzle 20° ; from first moving ring 22° ; from fixed ring 20° ; from second moving ring 24° .

Find the horse-power in the stage per pound of steam per second. Assume a velocity coefficient of 0.8 for the fixed and moving rings.

CHAPTER X

THEORY OF AIR COMPRESSORS AND MOTORS

122. The Transmission of Power by Compressed Air.—The method of operation may be briefly summed up as follows:—Air is compressed to the pressure required in “compressors.” After cooling, the air is taken along the supply mains and then expands in a motor cylinder, doing work in the same way as steam in a steam-engine cylinder. The ideal plant would compress the air isothermally, and then utilise the compressed air by expanding isothermally in the motor cylinder. In this case it is obvious that there would be no heat lost during transmission, and the efficiency of the process would be unity.

In practice it is impossible to compress the air isothermally, because from the nature of things the operation must be performed quickly, giving no time in which to remove the heat produced during compression. If no precautions are adopted the compression will be approximately adiabatic; various methods of approximating to isothermal compression are adopted, as will be discussed later.

Fig. 109 shows the indicator diagram for the ideal compressor and motor. The compressor diagram is represented by $dabc$, in which da is the suction stroke, ab isothermal compression, bc exhaust and delivery.

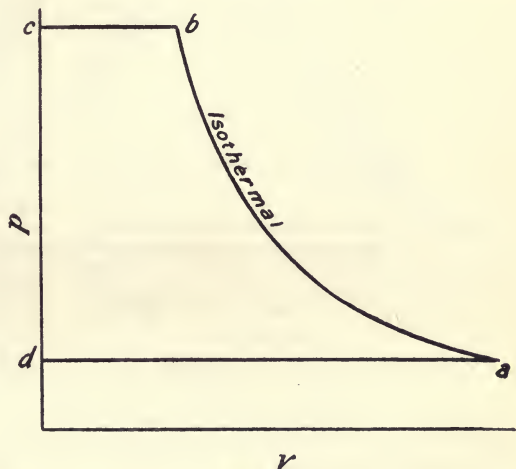

FIG. 109.

The work done on the air during compression is therefore given by the area $dabc$. Since there is no loss during transmission in this ideal case, Fig. 109 will also represent the indicator diagram for the motor, cb representing admission, ba isothermal expansion, ad exhaust, the area of the diagram representing the work done by the air during expansion. Hence the efficiency is given by—

$$\frac{\text{Work done on the air during compression}}{\text{Work done by the air during expansion}}$$

$$= \frac{\text{Area } dabc}{\text{Area } cbad} = 1$$

Consider now the actual case represented in Fig. 110. The compressor diagram is represented by *dabc*. Let the compression and expansion both be adiabatic. Then—

$$\text{Work done in compressor} = \text{area } dabc$$

The air is now cooled at constant pressure in the pipes, and the volume shrinks from *cb* to *cf*, the air returning to the temperature of the atmosphere. The temperature at *f* is now the same as at *a*.

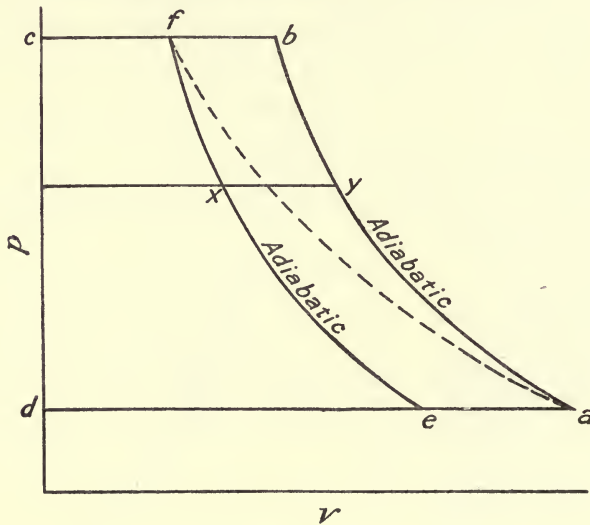

FIG. 110.

The motor diagram is represented by *cfed*, and

$$\text{Work done in motor cylinder} = \text{area } cfed$$

$$\text{Loss of work} = \text{area } fbae,$$

and
$$\text{Efficiency of transmission} = \frac{\text{area } cfed}{\text{area } dabc}$$

Draw any horizontal line *xy*, cutting the adiabatics in *x* and *y*.

Let the states of the air at *a*, *b*, *f*, and *e* be P_a, V_a, T_a ; P_b, V_b, T_b ; and P_f, V_f, T_f ; and P_e, V_e, T_e , respectively.

Then—
$$\frac{T_b}{T_a} = \left(\frac{P_b}{P_a}\right)^{\frac{\gamma-1}{\gamma}} = \left(\frac{P_f}{P_e}\right)^{\frac{\gamma-1}{\gamma}} = \frac{T_f}{T_e} \dots \dots (1)$$

and
$$\frac{V_b}{V_f} = \frac{T_b}{T_f} = \frac{T_a}{T_e} = \frac{T_y}{T_x} = \text{constant} \dots \dots \dots (2)$$

$$\therefore \text{efficiency} = \frac{fed}{dabc} = \frac{cf}{cb} = \frac{V_f}{V_b} = \frac{T_f}{T_b} = \frac{T_e}{T_a} = \frac{T_c}{T_f}$$

Hence efficiency $= \frac{T_e}{T_f} = \left(\frac{P_e}{P_f}\right)^{\frac{\gamma-1}{\gamma}}$ from (1)
 $= \left(\frac{1}{r}\right)^{\frac{\gamma-1}{\gamma}} \dots \dots \dots (3)$

where r = ratio of expansion or compression pressures.

If the compression is performed isothermally along af it will be obvious that the work done during compression is less by the amount $fb a$. It will also be noticed that a horizontal line such as xy cuts the two adiabatics fe and ba in a constant ratio, as shown by equation (2).

123. Methods of reducing the Losses during Compression and Expansion.—Since by compressing and expanding the air at constant temperature results in maximum efficiency, the object aimed at is to compress and expand as nearly as possible along isothermals.

In Fig. 110 it is shown that the extra work necessary when compressing adiabatically is represented by $fb a$, and the loss of work during adiabatic expansion by fae . To reduce these losses the following methods are adopted:—

(1) The temperature is kept down during compression by injecting water in the form of a spray, so that instead of getting an adiabatic ab the compression curve is ac (Fig. 111) following the law $p v^{1.2} = \text{constant}$. The saving is then represented by the shaded area abc .

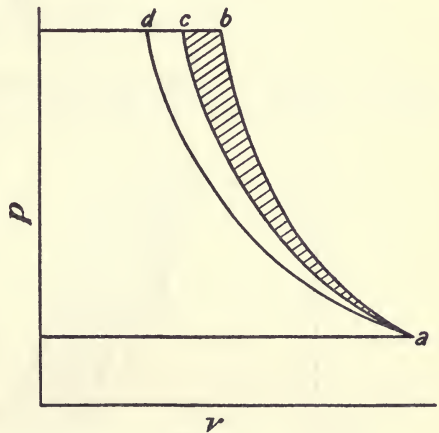

FIG. 111.

In early plants a water jacket was fitted to the compression cylinder. This, however, was not very efficient, and at present is only recommended for use in plants where the injection of a spray of cold water is impossible owing to its impurity, or in cases where additional mechanism is to be avoided.

(2) The most successful way of preventing the accumulation of heat in the compressor is to employ multiple stage compression with or without spray injection. Fig. 112 shows the saving with two-stage compressor, and Fig. 113 with three-stage compression.

Considering Fig. 113 only, ab is compression according to some law $p v^n = \text{const.}$ [for adiabatic it is $p v^{1.4} = \text{constant}$, and with spray injection $p v^{1.2} = \text{constant}$]. The air is then cooled at constant pressure bc down to

the original temperature, then follows compression cd ($pv^n = \text{const.}$), and cooling at constant pressure de to the original temperature, and compression

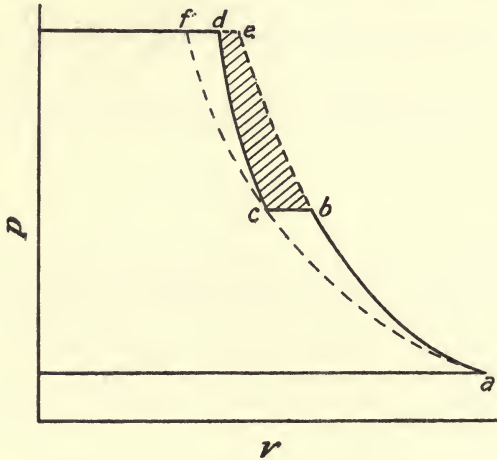

FIG. 112.

ef ($pv^n = \text{const.}$). In this way the curve approximates to the isothermal $aceg$, the saving being represented by the shaded area.

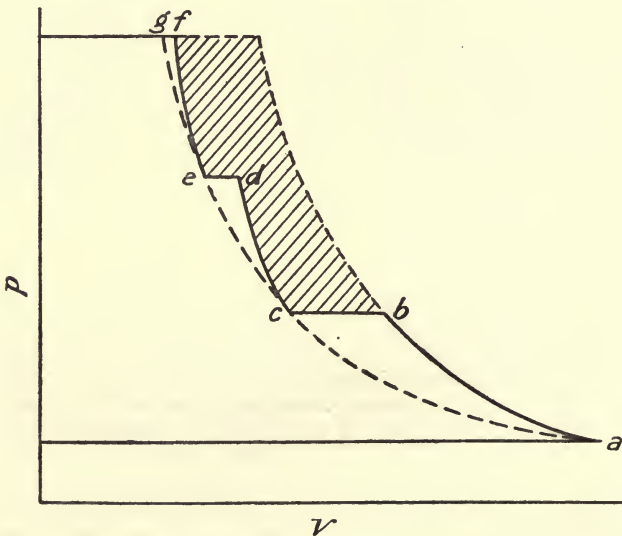

FIG. 113.

The expansion in the motor may be carried out in two or more stages in the same way, with a resulting gain in the work done as the expansion

curve approximates to the isothermal. The theory of the different types of air compressors and motors will now be discussed.

124. Air Compressors. Case I. Simple Compressor with Adiabatic Compression.—The $p v$ diagram is shown in Fig. 114:

Compression AB. Work done = $\frac{p_2 v_2 - p_1 v_1}{\gamma - 1}$ (Art. 9, Eq. (2))

The temperature rises to $T_2 = T_1 \cdot \left(\frac{P_2}{P_1}\right)^{\frac{\gamma-1}{\gamma}}$ (Art. 11 (6)) . (1)

Exhaust BC. Work done = $p_2 v_2$.

Suction DA. Work done = $p_1 v_1$.

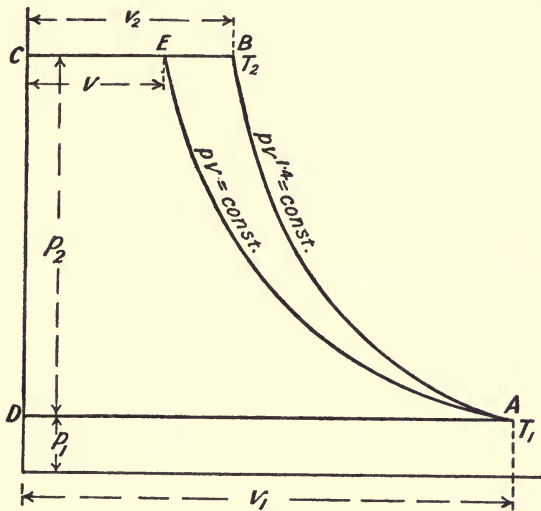

FIG. 114.

Hence total work done per lb. of air per cycle, W_{BD} , is given by the expression—

$$W_{BD} = \frac{p_2 v_2 - p_1 v_1}{\gamma - 1} + p_2 v_2 - p_1 v_1$$

$$= \frac{\gamma}{\gamma - 1} (p_2 v_2 - p_1 v_1) \dots \dots \dots (2)$$

$$= R \cdot \frac{\gamma}{\gamma - 1} (T_2 - T_1) \text{ since } p v = RT. \dots (3)$$

Substituting in (3) the value of T_2 from (1) we have—

$$W_{BD} = R \cdot \frac{\gamma T_1}{\gamma - 1} \left[\left(\frac{p_2}{p_1}\right)^{\frac{\gamma-1}{\gamma}} - 1 \right] \dots \dots \dots (4)$$

If, however, the compression were isothermal, the work done W_{DE} would be

$$W_{DE} = p_1 v_1 \log_e \frac{v_1}{v} + p_2 v - p_1 v_1 = p_1 v_1 \log_e \frac{p_2}{p_1}$$

or

$$= RT_1 \log_e \frac{p_2}{p_1} \quad \dots (5)$$

Treating the isothermal compressor as the standard ideal case since it wastes no energy in uselessly heating the air, and calling its efficiency unity, or 100 per cent., the efficiency of the adiabatic compressor, *Case I.* is

$$\text{Efficiency } \eta = \frac{RT_1 \log_e \frac{p_2}{p_1}}{R \cdot T_1 \cdot \frac{\gamma}{\gamma - 1} \left[\left(\frac{p_2}{p_1} \right)^{\frac{\gamma-1}{\gamma}} - 1 \right]}$$

If r = ratio of compression pressures = $\frac{p_2}{p_1}$ we have

$$\eta = \frac{RT_1 \log_e r}{RT_1 \frac{\gamma}{\gamma - 1} \left[r^{\frac{\gamma-1}{\gamma}} - 1 \right]} = \frac{\log_e r}{\frac{\gamma}{\gamma - 1} \left(r^{\frac{\gamma-1}{\gamma}} - 1 \right)} \quad \dots (6)$$

125. Case II. Simple Compressor with Spray Injection.—

In this case the law of the compression curve will be $p v^n = \text{constant}$, where $n = 1.2$ about.

$$\text{The work done per pound} = RT_1 \cdot \frac{n}{n - 1} \left[\left(\frac{p_2}{p_1} \right)^{\frac{n-1}{n}} - 1 \right] \quad (1)$$

$$\text{Efficiency } \eta = \frac{\log_e r}{\frac{n}{n - 1} \left(r^{\frac{n-1}{n}} - 1 \right)} \quad \dots (2)$$

126. Case III. Two-Stage Adiabatic Compressor.—

The $p v$ diagram is shown in Fig. 115. The work done per lb. of air per cycle is now

$$W = \text{area ABGF} + \text{area CDEG}$$

$$W = RT_1 \frac{\gamma}{\gamma - 1} \left[\left(\frac{p_2}{p_1} \right)^{\frac{\gamma-1}{\gamma}} - 1 \right] + RT_1 \frac{\gamma}{\gamma - 1} \left[\left(\frac{p_3}{p_2} \right)^{\frac{\gamma-1}{\gamma}} - 1 \right]$$

$$W = RT_1 \frac{\gamma}{\gamma - 1} \left[\left(\frac{p_2}{p_1} \right)^{\frac{\gamma-1}{\gamma}} + \left(\frac{p_3}{p_2} \right)^{\frac{\gamma-1}{\gamma}} - 2 \right] \quad \dots (1)$$

Differentiating (1) with respect to p_2 , we have, since p_1 and p_3 are constants,

$$\begin{aligned} \frac{dW}{dp_2} &= \frac{\gamma - 1}{\gamma} \left(\frac{p_2}{p_1} \right)^{\frac{\gamma-1}{\gamma} - 1} \cdot \frac{1}{p_1} + \frac{\gamma - 1}{\gamma} \left(\frac{p_3}{p_2} \right)^{\frac{\gamma-1}{\gamma} - 1} \times - \frac{p_3}{p_2^2} = 0 \text{ for a minimum} \\ &= \frac{\gamma - 1}{\gamma} \cdot p_2^{-\frac{1}{\gamma}} \cdot \frac{p_1^{\frac{1}{\gamma}}}{p_1} + \frac{1 - \gamma}{\gamma} \cdot p_3^{1 - \frac{1}{\gamma}} \cdot p_2^{\frac{1}{\gamma} - 2} = 0 \end{aligned}$$

Dividing out by $p_2^{-\frac{1}{\gamma}}$ we have

$$\begin{aligned}
 &= \frac{\gamma - 1}{\gamma} p_1^{\frac{1-\gamma}{\gamma}} = \frac{\gamma - 1}{\gamma} p_3^{\frac{\gamma-1}{\gamma}} \cdot p_2^{\frac{2(1-\gamma)}{\gamma}} \\
 &\therefore p_2^{\frac{2(1-\gamma)}{\gamma}} = \frac{p_1^{\frac{1-\gamma}{\gamma}}}{p_3^{\frac{\gamma-1}{\gamma}}} \\
 &\therefore p_2 = \sqrt{p_1 p_3} \dots \dots \dots (2)
 \end{aligned}$$

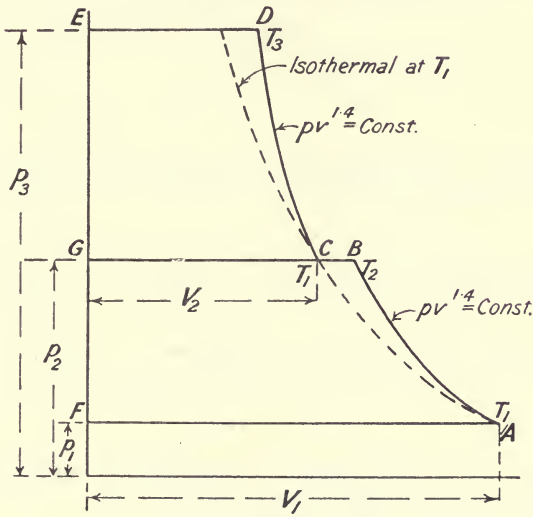

FIG. 115.

Hence for the least work done, the ratios of compression in the two stages are such that $p_2 = \sqrt{p_1 p_3}$, or

$$\frac{p_2}{p_1} = \frac{p_3}{p_2} \dots \dots \dots (2A)$$

Calling V_1 the volume of the first cylinder and V_2 the volume of the second cylinder, we see that

$$\frac{V_1}{V_2} = \frac{p_2}{p_1} = \sqrt{\frac{p_3}{p_1}} \dots \dots \dots (3)$$

Also since

$$\frac{T_2}{T_1} = \left(\frac{p_2}{p_1}\right)^{\frac{\gamma-1}{\gamma}}$$

and

$$\frac{T_3}{T_1} = \left(\frac{p_3}{p_2}\right)^{\frac{\gamma-1}{\gamma}}$$

$$\frac{T_2}{T_1} = \frac{T_3}{T_1} \dots \dots \dots (4)$$

Equation (4) shows that the ratio of the initial and final temperatures during compression is the same for each stage when the work of compression is a minimum, since at the end of the first stage the temperature is cooled in the intercooler from T_2 to T_1 .

Substituting (2A) in (1) we have

$$W = RT_1 \frac{2\gamma}{\gamma - 1} \left[\left(\frac{p_3}{p_1} \right)^{\frac{\gamma-1}{2\gamma}} - 1 \right] \dots \dots \dots (5)$$

In this case $r = \frac{p_3}{p_1}$, and the efficiency is given by

$$\eta = \frac{\log_e r}{\frac{\gamma-1}{2\gamma} \left(r^{\frac{2\gamma}{\gamma-1}} - 1 \right)} \dots \dots \dots (6)$$

127. Case IV. Two-Stage Compression with Spray Injection.

—The law of the compression curve will be $pv^n = \text{constant}$ when $n = 1.2$ about.

The work done $W = RT_1 \cdot \frac{2n}{n-1} \left[\left(\frac{p_3}{p_1} \right)^{\frac{n-1}{2n}} - 1 \right] \dots \dots (1)$

and efficiency $\eta = \frac{\log_e r}{\frac{2n}{n-1} \left(r^{\frac{n-1}{2n}} - 1 \right)} \dots \dots \dots (2)$

128. Case V. Three-Stage Compression with Adiabatic Compression.—The pv diagram is shown in Fig. 116.

The work done per lb. of air per cycle is now

$$\begin{aligned} W &= \text{area ABKL} + \text{area CDHK} + \text{area EFGH} \\ &= RT_1 \frac{\gamma}{\gamma - 1} \left[\left(\frac{p_2}{p_1} \right)^{\frac{\gamma-1}{\gamma}} - 1 \right] + RT_1 \frac{\gamma}{\gamma - 1} \left[\left(\frac{p_3}{p_2} \right)^{\frac{\gamma-1}{\gamma}} - 1 \right] \\ &\quad + \frac{\gamma}{\gamma - 1} RT_1 \left[\left(\frac{p_4}{p_3} \right)^{\frac{\gamma-1}{\gamma}} - 1 \right] \dots \dots \dots (1) \end{aligned}$$

For the least work done the same conditions will hold as for the two-stage process, so that

$$\frac{p_2}{p_1} = \frac{p_3}{p_2} = \frac{p_4}{p_3} \dots = \frac{p^n}{p^{n-1}} \text{ generally where } n = \text{number of stages}$$

and the ratio of the temperatures during each stage will be the same.

Hence we have

$$W = RT_1 \cdot \frac{\gamma}{\gamma - 1} \left[\left(\frac{p_2}{p_1} \right)^{\frac{\gamma-1}{\gamma}} + \left(\frac{p_3}{p_2} \right)^{\frac{\gamma-1}{\gamma}} + \left(\frac{p_4}{p_3} \right)^{\frac{\gamma-1}{\gamma}} - 3 \right] \dots (2)$$

and since

$$\frac{p_2}{p_1} = \frac{p_4}{p_3}$$

$$p_2 = \frac{p_1 p_4}{p_3} = \frac{p_1 p_4}{\sqrt{p_2 p_4}} = \frac{p_1 p_4^{\frac{1}{2}}}{p_2^{\frac{1}{2}}}$$

$$\therefore p_2^{\frac{3}{2}} = p_1 \cdot p_4^{\frac{1}{2}}$$

or

$$\frac{p_2}{p_1} = \left(\frac{p_4}{p_1}\right)^{\frac{1}{3}} \dots \dots \dots (3)$$

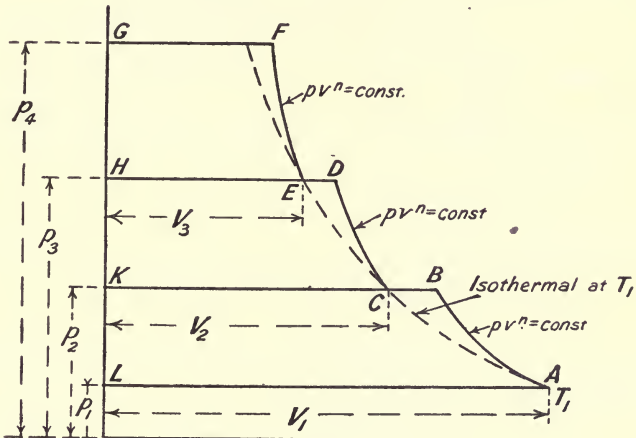

FIG. 116.

Substituting (3) in (2) we have

$$W = RT_1 \cdot \frac{3\gamma}{\gamma - 1} \left[\left(\frac{p_4}{p_1}\right)^{\frac{\gamma-1}{3\gamma}} - 1 \right] \dots \dots \dots (4)$$

and efficiency $\eta = \frac{\log_e r}{\frac{3\gamma}{\gamma + 1} \left[r^{\frac{\gamma-1}{3\gamma}} - 1 \right]}$ where $r = \frac{p_4}{p_1}$. . . (5)

The ratio of the volumes of the cylinders will be

$$\frac{V_1}{V_2} = \frac{V_2}{V_3} = \left(\frac{p_4}{p_1}\right)^{\frac{1}{3}} \text{ or } \sqrt[3]{\frac{p_4}{p_1}}$$

129. Case VI. Three-Stage Compression with Spray Injection.

—The law of the compression curve will be $p v^n = \text{constant}$, where $n = 1.2$ about.

The work done per lb. of air will be

$$W = RT_1 \cdot \frac{3n}{n - 1} \left[\left(\frac{p_4}{p_1}\right)^{\frac{n-1}{3n}} - 1 \right] \dots \dots \dots (1)$$

and efficiency $\eta = \frac{\log_e r}{\frac{3n}{n - 1} \left[r^{\frac{n-1}{3n}} - 1 \right]}$ (2)

EXAMPLE 1.—An air compressor is required to compress from one to ten atmospheres. Estimate the amount of work which must be expended for each lb. of air compressed in each of the above cases. Calculate also the efficiency in each case, the initial temperature being 60° Fahr.

Case I. Simple compressor with adiabatic compression.

By equation (4), Art. 124

$$\begin{aligned} \text{Work per lb. of air} &= \frac{53.18 \times 1.4 \times 521 \left[\left(\frac{10}{1} \right)^{\frac{1.4-1}{1.4}} - 1 \right]}{1.4 - 1} \\ &= \frac{53.18 \times 1.4 \times 521}{0.4} [1.931 - 1] = 90,260 \text{ ft.-lbs.} \end{aligned}$$

By equation (6), Art. 124,

$$\eta = \frac{\log_e 10}{\frac{1.4}{1.4 - 1} \left(10^{\frac{1.4-1}{1.4}} - 1 \right)} = \frac{2.303}{3.5 \times 0.931} = 0.706 \text{ or } 70.6 \text{ per cent.}$$

Case II. Simple compressor with spray injection.

By equation (1), Art. 125,

$$\begin{aligned} \text{Work per lb.} &= \frac{53.18 \times 1.2 \times 521 \left[10^{\frac{0.2}{1.2}} - 1 \right]}{0.2} \\ &= 53.18 \times 521 \times 6 \times 0.466 = 77,110 \text{ ft.-lbs.} \end{aligned}$$

By equation (2), Art. 125,

$$\begin{aligned} \eta &= \frac{\log_e 10}{1.2 \times \left(10^{\frac{0.2}{1.2}} - 1 \right)} = \frac{2.303}{6 \times 0.466} \\ &= 0.823 \text{ or } 82.3 \text{ per cent.} \end{aligned}$$

Case III. Two-stage adiabatic compression.

By equation (5), Art. 126,

$$\begin{aligned} W &= \frac{53.18 \times 521 \times 2 \times 1.4 \left[10^{\frac{0.4}{2.8}} - 1 \right]}{1.4 - 1} \\ &= \frac{53.18 \times 521 \times 2.8}{0.4} \times 0.39 = 75,630 \text{ ft.-lbs.} \end{aligned}$$

By equation (6), Art. 126,

$$\eta = \frac{\log_e 10}{\frac{2.8}{0.4} \times 0.39} = \frac{2.303}{7 \times 0.39} = 0.843, \text{ or } 84.3 \text{ per cent.}$$

Case IV. Two-stage compression with spray injection.

By equation (1), Art. 127,

$$\begin{aligned} W &= \frac{53.18 \times 521 \times 2.4 \left[10^{\frac{0.2}{2.4}} - 1 \right]}{0.2} = 53.18 \times 521 \times 12 \times 0.212 \\ &= 70,470 \text{ ft.-lbs.} \end{aligned}$$

By equation (2), Art. 127,

$$\eta = \frac{2.303}{12 \times 0.212} = 0.915, \text{ or } 91.5 \text{ per cent.}$$

Case V. Three-stage compression with adiabatic compression.

By equation (4), Art. 128,

$$W = \frac{53.18 \times 52.1 \times 4.2}{0.4} \left[10^{\frac{0.4}{4.2}} - 1 \right] = 53.18 \times 52.1 \times 10.5 \times 0.246$$

$$= 71,550 \text{ ft.-lbs.}$$

By equation (5), Art. 128,

$$\eta = \frac{2.303}{10.5 \times 0.246} = 0.891, \text{ or } 89.1 \text{ per cent.}$$

Case VI. Three-stage compression with spray injection.

By equation (1), Art. 129,

$$W = \frac{53.18 \times 52.1 \times 3.6}{0.2} \left[10^{\frac{0.2}{3.6}} - 1 \right] = 53.18 \times 52.1 \times 18 \times 0.136$$

$$= 67,810 \text{ ft.-lbs.}$$

By equation (2), Art. 129,

$$\eta = \frac{2.303}{18 \times 0.136} = 0.940, \text{ or } 94.0 \text{ per cent.}$$

EXAMPLE 2.—Calculate the size of the cylinder required for a double-acting air compressor of thirty-five indicated horse-power working as a simple compressor with spray injection, the law of compression being $p v^{1.2} = \text{constant}$, the ratio of compression being from 15 lbs. per square inch absolute to 120 lbs. per square inch absolute. Revs. per min. = 110, and average piston speed 560 ft. per min. Neglect clearance.

$$\text{Now, work done per lb. of air} = p_2 v_2 - p_1 v_1 + \frac{p_2 v_2 - p_1 v_1}{n - 1}$$

$$\therefore \text{Mean effective pressure} = p_2 \frac{v_2}{v_1} - p_1 + \frac{p_2 \cdot \frac{v_2}{v_1} - p_1}{n - 1} \quad \dots (1)$$

Also

$$p_1 v_1^n = p_2 v_2^n$$

$$\therefore \frac{v_1}{v_2} = \left(\frac{p_2}{p_1} \right)^{\frac{1}{n}} = \left(\frac{120}{15} \right)^{\frac{1}{1.2}} = 8^{\frac{5}{6}}$$

$$\therefore \log \frac{v_1}{v_2} = \frac{5}{6} \log 8 = \frac{5}{6} \times 0.9031 = 0.7526$$

$$\therefore \frac{v_1}{v_2} = 5.657$$

Substituting this value of $\frac{v_1}{v_2}$ in equation (1), we have

$$\text{Mean effective pressure} = \frac{120}{5.657} - 15 + \frac{120 - 15}{0.2}$$

$$= (21.21 - 15) \times \frac{1.2}{0.2} = 37.26 \text{ lbs. per sq. in.}$$

Let A = area of cylinder in square inches

$$\text{then } 37.26 \times 560 \times A = 35 \times 33,000$$

$$\therefore A = \frac{35 \times 33,000}{37.26 \times 560} = 55.37 \text{ square inches}$$

$$\therefore \text{Diameter} = \sqrt{\frac{55.37}{0.7854}} = 8.40 \text{ inches}$$

Since revs. per min. = 110, and there are 220 working strokes per minute (the compressor being double-acting), the stroke is

$$\frac{560}{220} = 2.545 \text{ feet} = 2 \text{ feet } 6\frac{1}{2} \text{ inches}$$

130. Effect of Clearance.—The clearance in the compressor cylinder should be as small as possible since its effect is to reduce the efficiency. This is shown in Fig. 117. During the suction stroke the

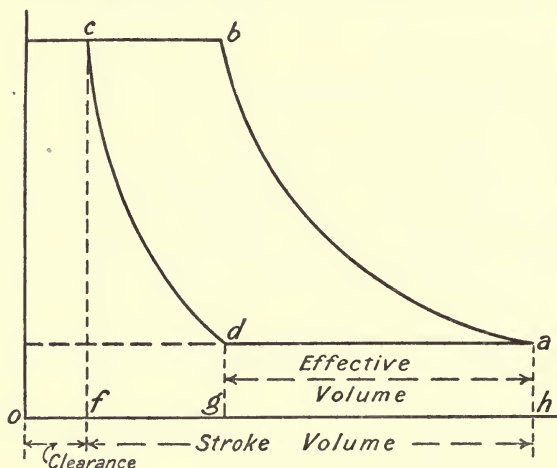

FIG. 117.

compressed air in the clearance space of expands to volume og , and less atmospheric air is drawn into the cylinder, the volume being only gh . The result is that the compressor must make a greater number of strokes to deal with the same volume of air, with a resulting greater loss by friction.

131. Air Motors.—On leaving the compressors the air is delivered by the mains to the motors, in which it may do work by expansion in a variety of ways. The air may be allowed to expand adiabatically, or it may be warmed during expansion by spray injection, or it may be expanded in two or more stages, being warmed in intermediate receivers of large enough capacity. The best method, both from a thermodynamic and a practical point of view, is to pass the air through a "preheater" or heating stove, and to commence the expansion in the motors with the air at a conveniently high temperature, and to work adiabatically. Occasionally, in very large motors, the air is heated up twice, being exhausted from the

high-pressure cylinder at a pressure of two or three atmospheres, and passing through a heater is expanded in the low-pressure cylinder down to atmospheric pressure. The theory of the different types of motors may be considered as follows:—

132. Case I. Simple Adiabatic Expansion.—Let the air enter the motor at pressure p_m , volume v_m , and temperature T_m , the suffixes indicating the state of the air in the mains at the motors. Fig. 118 represents the indicator diagram.

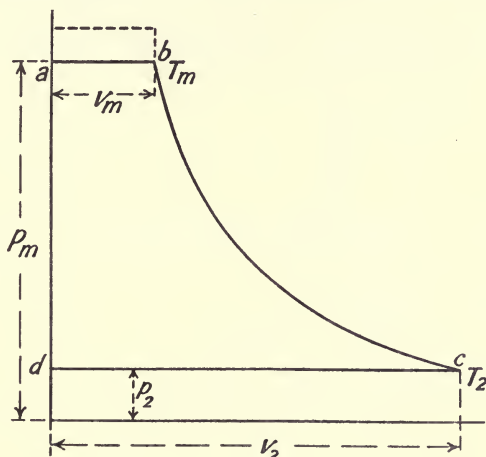

FIG. 118.

Then, work done per lb. $W = \frac{\gamma}{\gamma - 1} (p_m v_m - p_2 v_2) \dots (1)$

$$= \frac{\gamma}{\gamma - 1} \cdot R(T_m - T_2) \dots (2)$$

Now, $T_2 = T_m \left(\frac{p_2}{p_m}\right)^{\frac{\gamma-1}{\gamma}}$ (compare (1), Art. 124) $\dots (3)$

Hence, $W = RT_m \frac{\gamma}{\gamma - 1} \left[1 - \left(\frac{p_2}{p_m}\right)^{\frac{\gamma-1}{\gamma}} \right] \dots (4)$

If the expansion is isothermal

$$W = RT_m \log_{\epsilon} \frac{p_m}{p_2} \dots (5)$$

and the efficiency of the simple adiabatic motor is

$$\eta = \frac{\frac{\gamma}{\gamma - 1} \left[1 - \left(\frac{p_2}{p_m}\right)^{\frac{\gamma-1}{\gamma}} \right]}{\log_{\epsilon} \frac{p_m}{p_2}} \dots (6)$$

133. **Case II. Simple Motor, with Spray Injection.**—In this case the law of the expansion curve would be $p v^n = \text{constant}$, where n varies from 1.25 to 1.35, and the work per lb. would be

$$W = RT_m \cdot \frac{n}{n-1} \left[1 - \left(\frac{p_2}{p_m} \right)^{\frac{n-1}{n}} \right] \dots \dots \dots (1)$$

134. **Case III. Two-Stage Adiabatic Expansion.**—In this type of motor the air is heated in an intermediate receiver to approximately the same temperature as it entered the high-pressure cylinder from the mains, which will be the temperature of the atmosphere if no preheater be used. The indicator diagram is shown in Fig. 119.

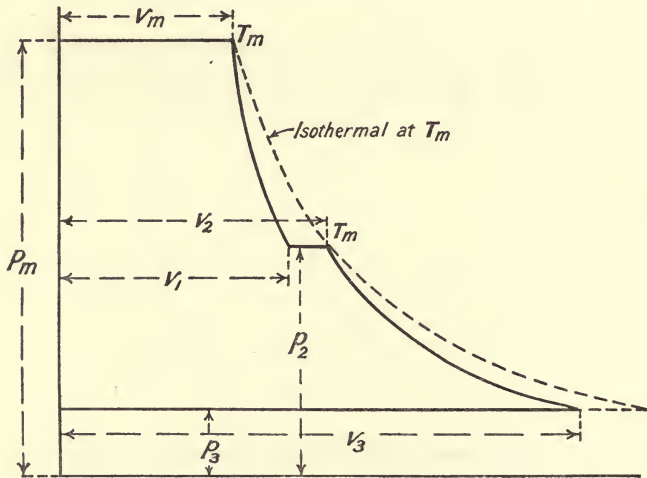

FIG. 119.

Work done per lb. in high-pressure cylinder is

$$W_1 = \frac{\gamma}{\gamma-1} (p_m v_m - p_2 v_1) = RT_m \cdot \frac{\gamma}{\gamma-1} \left[1 - \left(\frac{p_2}{p_m} \right)^{\frac{\gamma-1}{\gamma}} \right] \dots (1)$$

In the low-pressure cylinder

$$W_2 = \frac{\gamma}{\gamma-1} (p_2 v_2 - p_3 v_3) = RT_m \cdot \frac{\gamma}{\gamma-1} \left[1 - \left(\frac{p_3}{p_2} \right)^{\frac{\gamma-1}{\gamma}} \right] \dots (2)$$

Hence total work done is $W_1 + W_2$;

$$W = W_1 + W_2 = RT_m \cdot \frac{\gamma}{\gamma-1} \left[2 - \left(\frac{p_2}{p_m} \right)^{\frac{\gamma-1}{\gamma}} - \left(\frac{p_3}{p_2} \right)^{\frac{\gamma-1}{\gamma}} \right] \dots (3)$$

If $p_2 = \sqrt{p_m p_3}$, which is the condition for maximum work or for equal power developed in each cylinder

$$W = RT_m \cdot \frac{2\gamma}{\gamma-1} \left[1 - \left(\frac{p_3}{p_m} \right)^{\frac{\gamma-1}{2\gamma}} \right] \text{ (compare (5), Art. 126) } \dots (4)$$

In this case $r = \frac{p_m}{p_3}$, and the efficiency is given by

$$\eta = \frac{\log \epsilon r}{\frac{2\gamma}{\gamma - 1} \left[1 - \left(\frac{1}{r} \right)^{\frac{\gamma - 1}{2\gamma}} \right]} \dots \dots \dots (5)$$

135. Case IV.—In this type let each lb. of air entering from the

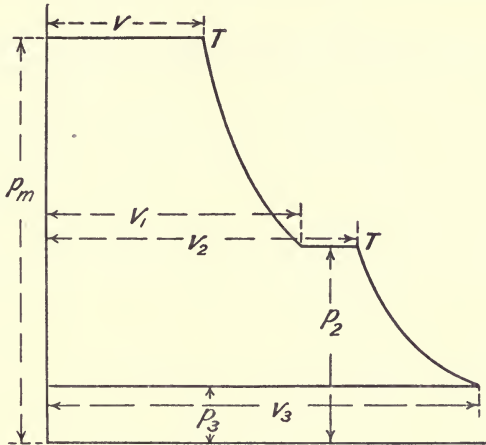

FIG. 120.

mains in the state $p_m v_m T_m$ be heated at constant pressure in a heater to temperature T, so that its volume becomes

$$v = v_m \frac{T}{T_m}$$

The indicator diagram is shown in Fig. 120.

Assuming adiabatic expansion, the work done per lb. in the high-pressure cylinder will be

$$\begin{aligned} W_1 &= p_m v + \frac{p_m v - p_2 v_1}{\gamma - 1} - p_2 v_1 \\ &= \frac{\gamma}{\gamma - 1} (p_m v - p_2 v_1) \dots \dots \dots (1) \end{aligned}$$

$$= RT \cdot \frac{\gamma}{\gamma - 1} \left[1 - \left(\frac{p_2}{p_m} \right)^{\frac{\gamma - 1}{\gamma}} \right] \dots \dots \dots (2)$$

Now, let the air on its way to the low-pressure cylinder pass through another heater which raises its temperature to T again. Assuming adiabatic expansion down to atmospheric pressure the work done in the low-pressure cylinder will be

$$\begin{aligned} W_2 &= \frac{\gamma}{\gamma - 1} (p_2 v_2 - p_3 v_3) \\ &= RT \cdot \frac{\gamma}{\gamma - 1} \left[1 - \left(\frac{p_3}{p_2} \right)^{\frac{\gamma - 1}{\gamma}} \right] \dots \dots \dots (3) \end{aligned}$$

Again, taking $p_2 = \sqrt{p_m p_3}$, we have the total work done

$$\begin{aligned} W_1 + W_2 &= RT \cdot \frac{\gamma}{\gamma - 1} \left[2 - \left(\frac{p_2}{p_m} \right)^{\frac{\gamma-1}{\gamma}} - \left(\frac{p_3}{p_2} \right)^{\frac{\gamma-1}{\gamma}} \right] \\ &= RT \cdot \frac{2\gamma}{\gamma - 1} \left[1 - \left(\frac{p_3}{p_m} \right)^{\frac{\gamma-1}{\gamma}} \right] \dots \dots \dots (4) \end{aligned}$$

Comparing this expression with (4), Art. 134, it will be seen that the work done depends upon the initial temperature of the air on entering the high-pressure cylinder.

136. Case V. Three-Stage Adiabatic Expansion Motor without Preheater but with Intermediate Heaters.—In this case the air enters the high-pressure cylinder at the temperature of the mains T_m , and after expansion is heated up to T_m again, and then passes into the intermediate cylinder. Exhausted from the intermediate cylinder it is again heated to T_m , and then expands adiabatically in the low-pressure cylinder down to atmospheric pressure. The indicator diagram is shown in Fig. 121.

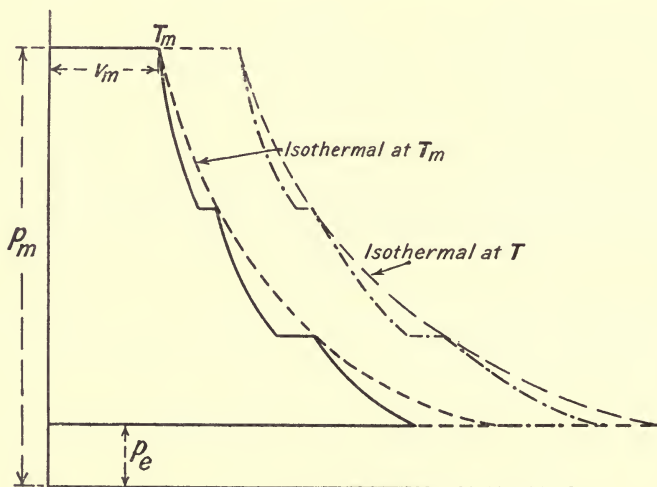

FIG. 121.

Reasoning in exactly the same way as in the case of the three-stage compressor, Art. 128, the work done per lb. of air reduces to the expression

$$W = RT_m \frac{3\gamma}{\gamma - 1} \left[1 - \left(\frac{p_e}{p_m} \right)^{\frac{\gamma-1}{3\gamma}} \right] \dots \dots \dots (1)$$

where p_e = exhaust pressure and p_m = pressure of mains. And the efficiency

$$\eta = \frac{RT_m \log_{\epsilon} \left(\frac{p_m}{p_e} \right)}{RT_m \frac{3\gamma}{\gamma - 1} \left[1 - \left(\frac{p_e}{p_m} \right)^{\frac{\gamma - 1}{3\gamma}} \right]}$$

$$= \frac{\log_{\epsilon} r}{\frac{3\gamma}{\gamma - 1} \left[1 - \left(\frac{1}{r} \right)^{\frac{\gamma - 1}{3\gamma}} \right]} \dots \dots \dots (2)$$

137. **Case VI.**—This case is similar to *Case V.* (Fig. 121), only a preheater is used in addition to the intermediate heaters, and in a similar manner to *Case IV.*, Art. 135, the work done per lb. of air is

$$W = RT \cdot \frac{3\gamma}{\gamma - 1} \left[1 - \left(\frac{p_e}{p_m} \right)^{\frac{\gamma - 1}{3\gamma}} \right] = RT \cdot \frac{3\gamma}{\gamma - 1} \left[1 - \left(\frac{1}{r} \right)^{\frac{\gamma - 1}{3\gamma}} \right] \dots (1)$$

The amount of preheating to be used depends upon the size of the motor and the desired temperature of exhaust. If the air enters without preheating it is exhausted at a low temperature (from 10° F. to 25° F.), in which state it may be used for cold storage or other similar purposes. If this low temperature is allowed there may be trouble caused by the deposition of snow in the cylinder, which may clog the valves. If, however, a considerable amount of preheating be used, the exhaust temperature may be *above* the atmospheric temperature, and with a large motor enough warm fresh air may be obtained for heating and ventilation purposes in the winter.

138. **Efficiency of Compressors.**—From tests made on the installation in Paris it appears that the mechanical efficiency of air compressors is about 86 per cent. The thermodynamic efficiency of compressors (taking the isothermal compressor to have an efficiency of 100 per cent.) is about 85 per cent. for single-stage and 92 per cent. for double-stage compressors, with spray injection. The loss in the mains for a five-mile transmission, due to leakage and fall of pressure, may be put at 3·8 per cent., so that the efficiency of the mains is about 96·2 per cent.

The thermodynamic efficiency of a simple adiabatic motor without preheater is about 77 per cent.; if fitted with a preheater the efficiency becomes about 85 per cent. In the case of a two-stage adiabatic motor the efficiency is about 90 per cent. without a preheater, and 110 per cent. to 113 per cent. if a preheater is used in conjunction with an intermediate heater.

EXAMPLES X

1. In a simple compressed air installation the compressor draws in air from the atmosphere, and compresses it adiabatically to twelve atmospheres. The temperature of the atmosphere is 60° F. In the mains the air is cooled at constant pressure to its original temperature, and is then delivered to the motor, where, after cut-off, it expands adiabatically to atmospheric pressure. Estimate the efficiency.

2. Estimate the B.H.P. of the engine required to drive an air compressor that takes in 260 cubic feet of air per minute at 60° F. and at atmospheric pressure, and compresses it adiabatically in one stage to ten atmospheres. Assume the mechanical efficiency of the compressor to be 86 per cent. and neglect all losses due to clearance, etc.

3. An engine is supplied with compressed air at 90 pounds per square inch absolute and at 65°F . The air is expanded, according to the law $pv^{1.3} = \text{const.}$, down to 15 pounds absolute, and then exhausted at that pressure. Determine the pounds of air that will be used per hour per I.H.P., and calculate the temperature of the air at the end of expansion. Neglect losses due to clearance, etc. (L.U.)

4. An ideal air compressor works between pressures of one and twelve atmospheres, with adiabatic compression, the initial temperature being 17°C . Estimate the amount of work which must be expended per pound of air compressed in the following cases:—

(a) Single-stage compression.

(b) Two-stage compression.

(c) Three-stage compression.

In (b) and (c) how much heat must be extracted in the intercoolers per pound of air compressed? ($C_p = 0.2375$).

5. Solve Problem 4, if by spray injection the law of the compression curves is $pv^{1.2} = \text{const.}$

6. Calculate the size of cylinder required for a double-acting air compressor of 50 I.H.P., working as a simple compressor, at 120 revolutions per minute, the law of compression being $pv^{1.2} = \text{const.}$ and the ratio of compression pressures being from 15 pounds per square inch absolute to 150 pounds absolute. Take an average piston speed of 600 feet per minute.

CHAPTER XI

COMBUSTION

COMBUSTION is a chemical combination of the inflammable constituents of a fuel with oxygen, the process resulting in the evolution of heat. The combustible elements in all fuels whether solid, liquid, or gaseous are carbon, hydrogen, and sulphur; of these, the sulphur is of minor importance in contributing to the heating value, because only small quantities are present, also, the injurious sulphurous acid, which it forms on burning, makes it undesirable to use a fuel which contains much sulphur, particularly for steam-raising purposes. The following table gives the approximate atomic and molecular weights of the various substances to which reference will be made in this chapter:—

	Atomic weight.	Molecular weight.
Hydrogen H ₂	1	2
Oxygen O ₂	16	32
Nitrogen N ₂	14	28
Carbon C	12	—
Sulphur S	32	—
Water H ₂ O	—	18
Carbon monoxide CO	—	28
Carbon dioxide CO ₂	—	44
Sulphur dioxide SO ₂	—	64
Marsh gas CH ₄	—	16

139. Combustion of Hydrogen.—The process is represented by the following equation, the molecular weight being written under each symbol:—

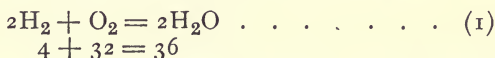

From (1) we see that 1 pound of hydrogen burning to steam (H₂O) requires 8 pounds of oxygen and yields 9 pounds of steam. In the process of combustion 1 pound of hydrogen gives out about 60,930 B.Th.U. (33,830 C.H.U.), but it forms 9 pounds of steam which absorbs about 9 × 970 = 8730 B.Th.U., leaving in round figures 52,200 B.Th.U. (29,000 C.H.U.) available for useful purposes. Now, in actual practice, the steam formed as a result of the combustion of hydrogen in a fuel passes off *as steam* in the flue gases leaving a boiler or in the exhaust gases from an internal combustion engine, hence the effective calorific value of hydrogen must be taken as 52,200 B.Th.U. (29,000 C.H.U.) per pound.

This figure is known as the *lower* or *effective calorific value*, whilst 60,930 B.Th.U. per pound is called the *higher* or *gross calorific value*. The lower calorific value is, therefore, the higher calorific value *minus* the latent heat of the steam formed during combustion.

140. Combustion of Carbon.—When carbon burns completely to CO₂ the process is represented by the equation

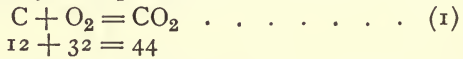

From (1) we see that 1 pound of carbon burning completely to CO₂ requires $\frac{32}{12} = 2.66$ pounds of oxygen and forms $\frac{44}{12} = 3.66$ pounds of CO₂. In the process of combustion 1 pound of carbon when burning to CO₂ gives out in round figures 14,540 B.Th.U. (8080 C.H.U.).

When 1 pound of carbon burns incompletely to CO it only gives out about 4400 B.Th.U. the action being represented by the equation.



From the above it is evident that incomplete combustion results in a loss of heat equal to 14,540 - 4400 = 10,140 B.Th.U. per pound of carbon so burned. Hence the importance of having *no* CO in the flue gases given off from a steam boiler furnace or in the exhaust gases from an internal combustion engine.

Also, if CO₂ at a high temperature comes in contact with incandescent carbon it is reduced to the lower oxide CO according to the equation

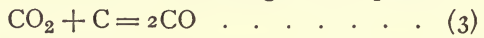

This occurs with a thick fire (see also Art. 152), and if the loss due to the presence of CO in the flue gases is to be prevented, air must be admitted *above* the fire to burn the CO to CO₂.

141. Combustion of Sulphur.—The action is represented by the equation



From (1) we see that 1 pound of sulphur burning to SO₂ requires 1 pound of oxygen and forms 2 pounds of SO₂. In the process of combustion 1 pound of sulphur gives out about 4000 B.Th.U.

142. Minimum Quantity of Air required for the Complete Combustion of 1 Pound of Solid or Liquid Fuel.—Let 1 pound of the fuel contain

- C pound of carbon
- H pound of hydrogen
- O pound of oxygen
- S pound of sulphur.

In Art. 140 we have seen that 1 pound of carbon requires 2.66 pounds of oxygen for its complete combustion. From Art. 139, 1 pound of hydrogen requires 8 pounds of oxygen, and from Art. 141 1 pound of sulphur requires 1 pound of oxygen. Hence, since air contains 23 per cent. by weight of oxygen, 1 pound of oxygen is contained in $\frac{100}{23} = 4.35$ pounds of air and—

- 1 pound of carbon requires $2.66 \times 4.35 = 11.6$ pounds of air
- 1 pound of hydrogen requires $8 \times 4.35 = 34.8$ pounds of air
- 1 pound of sulphur requires $1 \times 4.35 = 4.35$ pounds of air

Therefore 1 pound of the fuel will require

$$11.6 \times C + 34.8 \times H + 4.35 \times S \text{ pounds of air.} \quad (1)$$

EXAMPLE 1.—A sample of Russolene oil contains 86 per cent. by weight of carbon and 14 per cent. by weight of hydrogen; estimate the minimum quantity of air required for the complete combustion of 1 pound of the oil.

$$\begin{aligned} \text{Minimum quantity} &= 11.6 \times 0.86 + 34.8 \times 0.14 \\ &= 9.97 + 4.87 \\ &= 14.84 \text{ pounds} \end{aligned}$$

In actual practice about $1\frac{1}{2}$ times this quantity of air would be supplied in order to ensure complete combustion.

EXAMPLE 2.—The analysis of a sample of Nixon's navigation steam coal by weight is C 87.8 per cent., H 4.10 per cent., the remainder being ash, etc. If 18 pounds of air are supplied per pound of coal and the combustion is complete, estimate the composition of the products by weight.

$$\begin{aligned} \text{Total weight of products per pound of coal} &= 18 + \text{combustible in 1 pound} \\ &\quad \text{of coal} \\ &= 18.919 \text{ pounds.} \end{aligned}$$

Hence,

$$\begin{aligned} \text{Weight of CO}_2 \text{ per pound of coal} &= 0.878 \times \frac{44}{12} = 3.219 \\ \text{,, H}_2\text{O} \text{ ,, ,, ,,} &= 0.041 \times 9 = 0.369 \\ \text{,, N}_2 \text{ ,, ,, ,,} &= 18 \times \frac{77}{100} = 13.960 \end{aligned}$$

$$\text{Total} = 17.548 \text{ pounds}$$

$$\begin{aligned} \therefore \text{weight of oxygen (by difference)} &= 18.919 - 17.548 \\ &= 1.371 \text{ pounds} \end{aligned}$$

Hence the products of combustion will consist of

$$\text{Carbon dioxide (CO}_2\text{)} = \frac{3.219}{18.919} = 0.170 = 17.0 \text{ per cent.}$$

$$\text{Steam (H}_2\text{O)} = \frac{0.369}{18.919} = 0.019 = 1.9 \text{ ,,}$$

$$\text{Nitrogen (N}_2\text{)} = \frac{13.96}{18.919} = 0.738 = 73.80 \text{ ,,}$$

$$\text{Oxygen (O}_2\text{)} = \frac{1.371}{18.919} = 0.072 = 7.20 \text{ ,,}$$

143. Minimum Quantity of Air required for the Complete Combustion of 1 Cubic Foot of Gaseous Fuel.—The method of calculation will be best illustrated by means of an example. Taking a sample of coal gas whose volumetric analysis is hydrogen (H₂) = 46.0 per cent., marsh gas (CH₄) = 39.5 per cent., carbon monoxide (CO) = 7.5 per cent., nitrogen N₂ = 0.5 per cent., water vapour (H₂O) = 2.0 per cent., the method of procedure is as follows:—

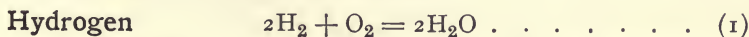

i.e. 2 cub. ft. of hydrogen + 1 cub. ft. of oxygen give 2 cub. ft. of water vapour
 $\therefore 0.46 \quad \text{,,} \quad \text{,,} \quad + 0.23 \quad \text{,,} \quad \text{,,} \quad 0.46 \quad \text{,,} \quad \text{,,}$

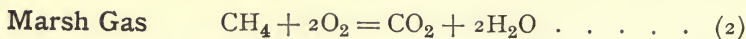

i.e. 1 cub. ft. of marsh gas + 2 cub. ft. of oxygen give 1 cub. ft. CO_2 + 2 cub. ft. water vapour
 $\therefore 0.395 \quad \text{,,} \quad \text{,,} \quad + 0.79 \quad \text{,,} \quad \text{,,} \quad 0.395 \text{ cub. ft. } \text{CO}_2 + 0.79$
cub. ft. water vapour

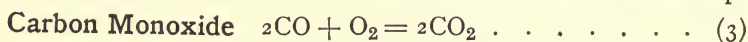

i.e. 2 cub. ft. of CO + 1 cub. ft. of oxygen give 2 cub. ft. of CO_2
 $\therefore 0.075 \quad \text{,,} \quad \text{,,} \quad + 0.0375 \quad \text{,,} \quad \text{,,} \quad 0.075 \quad \text{,,} \quad \text{,,}$

Hence 1 cubic foot of coal gas requires $0.23 + 0.79 + 0.0375 = 1.0575$ cubic feet of oxygen for complete combustion. Now air contains 21 per cent. by volume of oxygen, hence 1 cubic foot of the gas will require $1.0575 \times \frac{100}{21} = 5.03$ cub. ft. of air for its complete combustion.

The above might be put in algebraic form as follows:—

From (1)

- 1 cub. ft. of H requires 0.5 cub. ft. of O = $0.5 \times \frac{100}{21} = 2.38$ cub. ft. of air
 From (2)
- 1 cub. ft. of CH_4 requires 2 cub. ft. of O = $2 \times \frac{100}{21} = 9.52$ cub. ft. of air
 From (3)
- 1 cub. ft. of CO requires 0.5 cub. ft. of O = $0.5 \times \frac{100}{21} = 2.38$ cub. ft. air

Hence 1 cub. ft. of the gas containing these combustible constituents will require

$$2.38 \text{ H} + 9.52 \text{ CH}_4 + 2.38 \text{ CO cubic ft.}$$

Composition of the Products of Combustion.—The products will consist of

$$\begin{aligned} \text{CO}_2 &= 0.395 + 0.075 &= 0.47 \text{ cubic ft.} \\ \text{H}_2\text{O} &= 0.46 + 0.79 + 0.02 &= 1.27 \quad \text{,,} \\ \text{N}_2 &= 0.005 + 5.03 \times \frac{79}{100} &= 3.98 \quad \text{,,} \\ \hline \text{Total} &= 5.72 \quad \text{,,} \end{aligned}$$

Before combustion commenced the volume of the mixture of gas and air was $1 + 5.03 = 6.03$ cubic feet, hence the contraction in volume after combustion is $6.03 - 5.72 = 0.31$ cubic foot or $\frac{0.31}{6.03} \times 100 = 5.1$ per cent.

Calculation of the Quantity of Air supplied per Cubic Foot of Gas from the analysis of the Exhaust Gases leaving a Gas Engine.—The calculation requires the analysis of the gas and also that of the exhaust gases. In the example taken above the minimum quantity of air required per cubic foot of gas has been estimated as 5.03 cubic feet, the total volume of the products of combustion when the steam remains a vapour is 5.72 cubic feet. If, however, the steam had been condensed, the volume of the products (neglecting the very small volume of the resulting water) would be

$$5.72 - 1.27 = 4.45 \text{ cubic feet}$$

Now, when the exhaust gases are analysed the steam will be condensed, hence if x cubic feet be the amount of air supplied per cubic foot of gas in

excess of 5.03 cubic feet, the total volume of the actual products of combustion from 1 cubic foot of gas will be

$$x + 4.45 \text{ cubic feet}$$

Let O_2 be the percentage of oxygen (by volume) present in the exhaust gases, then the excess quantity of air which will contain this volume of oxygen will be

$$O_2 \times \frac{100}{21} \text{ cubic feet}$$

$$\therefore \frac{\text{volume of air left in actual products of combustion}}{\text{total volume of actual products of combustion}} = \frac{x}{x + 4.45}$$

Hence

$$\frac{x}{x + 4.45} = \frac{O_2 \times \frac{100}{21}}{100}$$

or

$$\begin{aligned} \frac{x}{x + 4.45} &= \frac{O_2}{21} \\ x(21 - O_2) &= 4.45 O_2 \\ x &= \frac{4.45 O_2}{21 - O_2} \dots \dots \dots (4) \end{aligned}$$

or expressing it in words—

excess air supplied (cubic feet) = volume of products when the minimum theoretical quantity of air is supplied (the steam formed being condensed)

$$\times \frac{\text{percentage of oxygen in exhaust gases}}{21 - \text{percentage of oxygen in exhaust gases}}$$

EXAMPLE.—With the above sample of coal gas the exhaust gas analysis gave 10 per cent. by volume of oxygen. Estimate the volume of air supplied per cubic foot of gas, and the contraction in volume after combustion.

From (4)

$$\text{excess air } x = \frac{4.45 \times 10}{21 - 10} = 4.045 \text{ cubic feet}$$

$$\therefore \left. \begin{array}{l} \text{total dry air supplied per cubic} \\ \text{foot of gas} \end{array} \right\} = 5.03 + 4.045 = 9.075 \text{ cubic feet}$$

$$\text{Volume of mixture before combustion} = 1 + 9.075 = 10.075 \text{ cubic feet}$$

$$\left. \begin{array}{l} \text{Volume of mixture after combustion} \\ \text{assuming water vapour condensed} \end{array} \right\} = 4.045 + 4.45 = 8.495 \text{ cubic feet}$$

$$\therefore \text{contraction due to combustion} = 10.075 - 8.495 = 1.580 \text{ cubic feet}$$

$$= \frac{1.58}{10.075} \times 100 = 15.6 \text{ per cent.}$$

In the engine cylinder the water vapour will not be condensed, and the actual volume of the products of combustion will be

$$\begin{aligned} x + 5.72 &= 4.045 + 5.72 \\ &= 9.765 \text{ cubic feet} \end{aligned}$$

$$\therefore \left. \begin{array}{l} \text{contraction in engine cylinder} \\ \text{due to combustion} \end{array} \right\} = 10.075 - 9.765 = 0.310 \text{ cubic foot}$$

$$= \frac{0.31}{10.075} \times 100 = 3.07 \text{ per cent.}$$

144. Calculation of the Quantity of Air supplied per Pound of Fuel from the Analysis of the Flue Gases leaving a Boiler.

- Let C = percentage of carbon in the fuel *by weight*.
- CO₂ = percentage of carbon dioxide in the flue gases *by weight*.
- CO = percentage of carbon monoxide in the flue gases *by weight*.
- N = percentage of nitrogen in the flue gases, *by weight*.
- O = percentage of oxygen in the flue gases *by weight*.

Considering 100 parts by weight of flue gases there are N parts of nitrogen in it. Now air contains 77 per cent. by weight of nitrogen.

∴ N parts of nitrogen are supplied with $\frac{100}{77} \times N$ parts of air. From Art. 140, it will be seen that in the 100 parts of flue gases there are

$$(CO_2 \times \frac{12}{44}) + (CO \times \frac{12}{28}) \text{ parts of carbon}$$

Hence the ratio of air to carbon is

$$\frac{N \times \frac{100}{77}}{(CO_2 \times \frac{12}{44}) + (CO \times \frac{12}{28})} \dots \dots \dots (1)$$

Now 1 pound of the fuel contains $\frac{C}{100}$ pounds of carbon.

Hence the weight of air supplied per pound of fuel burned is

$$\frac{N \times \frac{100}{77}}{(CO_2 \times \frac{12}{44}) + (CO \times \frac{12}{28})} \times \frac{C}{100} \text{ pounds} \dots \dots (2)$$

which reduces to

$$\frac{N}{21CO_2 + 33CO} \times C \text{ pounds}$$

If CO₂, CO, and N represent the percentages of carbon dioxide, carbon monoxide, and nitrogen respectively in the flue gases *by volume*, then the weight of air supplied per pound of fuel burned is given by

$$\frac{N \times \frac{100}{77} \times 28}{(CO_2 \times \frac{12}{44} \times 44) + (CO \times \frac{12}{28} \times 28)} \times \frac{C}{100} \text{ pounds}$$

where 28 = molecular weight of N₂ and also of CO

and 44 = molecular weight of CO₂

The above expression will be found to reduce to

$$\frac{N}{33(CO_2 + CO)} \times C \text{ pounds} \dots \dots \dots (3)$$

Loss of Heat by the Flue Gases escaping up the Chimney.

Let *s* = mean specific heat of the flue gases (about 0.238), *i.e.* the mean heat required to raise unit weight of the mixed gases one degree in temperature,

W = weight in pounds of the flue gases per pound of fuel burned,

*t*₁ = temperature of the flue gases leaving the boilers (Fahrenheit),

*t*₂ = temperature of the air in the boiler house (Fahrenheit),

then assuming that there is no preliminary heating of the air supply the heat carried away in the flue gases per pound of fuel is

$$W \times s(t_1 - t_2) \text{ British Thermal Units}$$

It may here be mentioned that the air supply should as far as possible be free from moisture, and further that it conduces to economy if it be heated, provided that such preheating is obtained at little cost. Any water vapour present in the air when it passes through the incandescent fuel will become dissociated into its constituent hydrogen and oxygen, and then will again re-combine when they leave the furnace; but they will leave at the higher temperature of the chimney, and the net result is that some heat has been lost in raising the temperature of the water vapour, or expressed in other words, the mean specific heat of the flue gases is higher than if the air had been dry.

145. Calculation of the Mean Specific Heat of the Flue Gases leaving a Boiler.—The calculation requires the analysis of the fuel and also the analysis of the flue gases. The method will be best illustrated by means of a numerical example. Taking the following analyses:—

Analysis of Fuel by Weight.

C		87·30	per cent.
H		0·78	„
Ash		8·27	„
Other matters		2·36	„

Analysis of Dry Flue Gases by Volume.

CO ₂		9·88	per cent.
CO		0·05	„
O ₂		9·82	„
N ₂		80·25	„

The first step in the calculation is to convert the analysis of the dry flue gases *by volume* (the gases are always analysed by volume) into the analysis *by weight*. By multiplying each of the volume proportions by the corresponding molecular weight, adding the products so obtained, and then dividing each separate product by the sum of all the products, the proportion by weight of each gas present may be obtained.

Constituent.	By volume.	× Molecular. weight	=	By weight.	=	
CO ₂	= 0·0988	× 44	=	4·348	= 0·145	= 14·5 per cent.
CO	= 0·0005	× 28	=	0·014	= 0·0005	= 0·05 „
O ₂	= 0·0982	× 32	=	3·142	= 0·1055	= 10·55 „
N ₂	= 0·8025	× 28	=	22·470	= 0·749	= 74·90 „
Total . .				29·974	1·000	100·0 „

Therefore in 100 pounds of dry flue gases there are

$$\begin{aligned} & 14\cdot5 \times \frac{12}{44} + 0\cdot05 \times \frac{12}{28} \\ & = 3\cdot95 + 0\cdot02 \\ & = 3\cdot97 \text{ pounds of carbon} \end{aligned}$$

Hence the weight of dry flue gases per pound of dry fuel will be

$$\frac{100 \times 6\cdot0873}{3\cdot97} = 22\cdot0 \text{ pounds}$$

But the 0.0078 pound of hydrogen in the fuel produces $0.0078 \times 9 = 0.070$ pound of steam, hence the actual weight of each constituent in the flue gases from 1 pound of dry fuel is

Constituent.	Weight in pounds per pound of dry fuel burned.	Weight in pounds of each constituent in 1 pound of flue gases.
CO ₂	$22.0 \times 0.145 = 3.190$	$\frac{3.190}{22.07} = 0.1445$
CO	$22.0 \times 0.0005 = 0.011$	$\frac{0.011}{22.07} = 0.0005$
O ₂	$22.0 \times 0.1055 = 2.321$	$\frac{2.321}{22.07} = 0.1052$
N ₂	$22.0 \times 0.794 = 16.478$	$\frac{16.478}{22.07} = 0.7467$
H ₂ O	— 0.070	$\frac{0.07}{22.07} = 0.0031$
	22.070	1.0000

The specific heats at constant pressure of the above gases may be taken as:—

$$\begin{aligned} \text{CO}_2 &= 0.216 \\ \text{CO} &= 0.245 \\ \text{O}_2 &= 0.218 \\ \text{N}_2 &= 0.244 \\ \text{H}_2\text{O} &= 0.480 \end{aligned}$$

Hence the mean specific heat of the flue gases is:—

$$(0.1445 \times 0.216) + (0.0005 \times 0.245) + (0.1052 \times 0.218) + (0.7467 \times 0.244) + (0.0031 \times 0.48) = 0.238$$

146. Heat carried away by the Products of Combustion and Excess Air.—In drawing up the Heat Balance for a boiler it is a common practice to divide the heat lost in the flue gases into two parts, viz. that carried away by the products of combustion, and that carried away by the excess air supplied. The method of doing this will be best illustrated by means of an example.

EXAMPLE.—The analysis of a certain oil fuel used in a boiler trial was C 86 per cent., H 14 per cent. The volumetric analysis of the flue gases was CO₂ 9.4 per cent., CO 1 per cent., O₂ 10.1 per cent., N₂ 79.5 per cent. Estimate, per pound of fuel burned, the heat carried away by the products of combustion, and also by the excess air, the temperature of the flue gases being 600° F., and of the air supply 60° F.

The total weight of flue gases per pound of fuel may first be found as follows:—

Using equation 3, Art. 144, we have

$$\begin{aligned} \text{Air supplied per pound of fuel} &= \frac{N}{33(\text{CO}_2 + \text{CO})} \times C \\ &= \frac{79.5}{33(9.4 + 1)} \times 86 \\ &= 19.92 \text{ pounds} \end{aligned}$$

$$\begin{aligned} \text{The total weight of gases} &= 19.92 + \text{combustible in 1 pound of fuel} \\ &= 19.92 + 1 \\ &= 20.92 \text{ pounds} \end{aligned}$$

$$\begin{aligned} \left. \begin{array}{l} \text{Minimum quantity of air} \\ \text{theoretically required per} \\ \text{pound of fuel} \end{array} \right\} &= 11.6C + 34.8H \text{ ((1), Art. 142)} \\ &= 11.6 \times 0.86 + 34.8 \times 0.14 \\ &= 14.84 \text{ pounds} \end{aligned}$$

$$\begin{aligned} \text{Excess air supplied} &= 19.92 - 14.84 \\ &= 5.08 \text{ pounds} \end{aligned}$$

$$\therefore \left. \begin{array}{l} \text{weight of products of} \\ \text{combustion from 1 pound} \\ \text{of fuel} \end{array} \right\} = 15.84 \text{ pounds} = 20.92 - 5.08$$

We now require the weight of each constituent in this 15.84 pounds of products of combustion. Converting the volumetric analysis of the gases into the analysis by weight, we have—

Con- stituent.	By volume.	Molecular weight.	By weight.	
CO ₂	= 0.094	× 44	= 4.136	= 0.138 = 13.8 per cent.
CO	= 0.010	× 28	= 0.280	= 0.009 = 0.9 "
O ₂	= 0.101	× 32	= 3.232	= 0.108 = 10.8 "
N ₂	= 0.795	× 28	= 22.260	= 0.745 = 74.5 "
Total . .			29.908	1.000 100.0

We next require the proportion of carbon burned to CO₂ and CO respectively.

$$\begin{aligned} \text{In 13.8 parts of CO}_2 \text{ there are } &13.8 \times \frac{3}{11} = 3.76 \text{ parts of carbon} \\ \text{" } 0.9 \text{ " CO " } &0.9 \times \frac{3}{7} = \underline{0.38} \text{ " " } \\ \text{Total . .} &4.14 \text{ " " } \end{aligned}$$

$$\therefore \text{proportion of carbon burned to CO}_2 = \frac{3.76}{4.14}$$

$$\text{" " " CO} = \frac{0.38}{4.14}$$

Hence per pound of fuel burned

$$\text{Weight of CO}_2 = \frac{11}{3} \times 0.86 \times \frac{3.76}{4.14} = 2.86 \text{ pounds}$$

$$\text{Weight of CO} = \frac{7}{3} \times 0.86 \times \frac{0.38}{4.14} = 0.18 \text{ pound}$$

$$\begin{aligned} \text{Weight of H}_2\text{O formed} &= \text{weight of hydrogen} \times 9 \\ &= 0.14 \times 9 = 1.26 \text{ pounds} \end{aligned}$$

$$\begin{aligned} \text{Weight of N}_2 \text{ (by difference)} &= 15.84 - (2.86 + 0.18 + 1.26) \\ &= 11.54 \text{ pounds} \end{aligned}$$

We next require the proportion by weight of each constituent in the products of combustion.

$$\text{CO}_2 = \frac{2.86}{15.84} = 0.181$$

$$\text{CO} = \frac{0.18}{15.84} = 0.011$$

$$\text{H}_2\text{O} = \frac{1.26}{15.84} = 0.079$$

$$\text{N}_2 = \frac{11.54}{15.84} = 0.729$$

$$\text{Total} = 1.000$$

Hence, mean specific heat of the products of combustion

$$= (0.181 \times 0.216) + (0.011 \times 0.245) + (0.079 \times 0.48) + (0.729 \times 0.244) \\ = 0.2575$$

$$\therefore \text{heat carried away by products of combustion} = 15.84 \times 0.2575 (600 - 60) \\ = 2202 \text{ B.Th.U.}$$

$$\text{Heat carried away by excess air} = 5.08 \times 0.2375 (600 - 60) \\ = 651 \text{ B.Th.U.}$$

147. Calorific Value of Solid and Liquid Fuels.—Several formulæ have been given from time to time by means of which the calorific value of a fuel may be calculated from its chemical analysis. In Dulong's formula it is assumed that all the oxygen present in a fuel is already combined with one-eighth of its weight of hydrogen in the proportion to form water so that the hydrogen *available for combustion* is only $\text{H} - \frac{\text{O}}{8}$. Using the same notation as in Art. 142, the lower calorific value according to this formula is

$$14,540\text{C} + 52,200 \left(\text{H} - \frac{\text{O}}{8} \right) + 4000\text{S} \text{ B.Th.U. per pound.}$$

$$\text{or} \quad 8080\text{C} + 29,000 \left(\text{H} - \frac{\text{O}}{8} \right) + 2220\text{S} \text{ C.H.U.} \quad ,,$$

in which the constants denote the calorific values of the various combustible elements.

The above formula invariably gives a result too low as compared with the value obtained by direct calorimetric tests, probably because more hydrogen is free than is assumed. On the other hand, if *all* the hydrogen in a fuel is assumed available for combustion the calorific value obtained (when using the above constants) is usually too high. The above formula assumes that the amount of oxygen present in a fuel is known accurately. This is not so because it is always found by difference, being practically a fictitious figure which contains all the errors of the analysis.

Also the same formula will not be equally correct for both solid and liquid fuels on account of the complex composition of the hydrocarbons in oil fuels, and in addition, it should be remembered that the calorific value of carbon depends upon its physical state, diamond, graphite, and amorphous carbon all being different.

The Author found¹ that for many steam coals used in practice the formula

$$14,400\text{C} + 52,200\text{H B.Th.U. per pound}$$

or $8,000\text{C} + 29,000\text{H C.H.U.},,$

gives results for the lower calorific value very closely in agreement with those obtained in the "Bomb" calorimeter, whilst for oil fuels the formula

$$13,500\text{C} + 52,200\text{H B.Th.U. per pound}$$

or $7,500\text{C} + 29,000\text{H C.H.U.},,$

gives results practically the same as those given by the Bomb calorimeter.

The calorific value of a solid or a liquid fuel can only be determined *accurately* by direct experiment in an approved calorimeter such as the Bomb calorimeter. The following tables give the calorific values of various solid and liquid fuels:—

COMPOSITION AND CALORIFIC VALUE OF VARIOUS SOLID FUELS.

Description of fuel.	Moisture, per cent.	Carbon, per cent.	Hydro- gen, per cent.	Oxygen +nitro- gen, per cent.	Sulphur, per cent.	Higher calorific value.	
						Calories, per gramme.	B.Th.U. per pound.
Wood (ordinary) . . .	28·9	36·4	4·6	29·6	—	3310	5,960
Wood (dried) . . .	6·9	47·4	5·6	41·0	—	4480	8,060
Peat (poor) . . .	20·8	40·8	3·3	31·4	—	3770	6,790
Peat (air dried). . .	6·1	53·2	5·5	35·0	—	5490	9,880
Cannel coal (Wigan) . .	0·6	78·4	5·1	11·20	0·4	7760	13,970
Cannel coal (Scotch) . .	4·0	75·42	6·18	9·98	2·18	7500	13,550
Yorkshire caking coal . .	2·20	84·10	4·93	7·00	0·55	7420	13,370
Durham caking coal . .	1·14	84·34	5·30	6·00	0·78	8300	14,870
Newcastle steam coal . .	1·20	81·30	5·30	9·90	1·20	8160	14,690
Durham steam coal . .	0·80	81·50	4·60	6·00	1·20	7970	14,350
Welsh steam coal . . .	—	83·80	4·80	5·10	1·40	8050	14,490
Nixon's navigation steam coal	1·00	87·80	4·10	5·00	—	8580	15,450
Slack coal	7·30	67·90	4·90	16·00	1·30	7220	13,000
Welsh anthracite . . .	—	91·50	3·50	3·40	0·60	8460	15,220
American „	3·40	86·40	2·00	2·20	—	7480	13,470
Average English coke . .	4·80	88·40	1·40	3·27	0·35	7600	13,600

¹ See *Engineer*, Feb. 17, 1911.

COMPOSITION AND CALORIFIC VALUE OF VARIOUS LIQUID FUELS.¹

Description of fuel.	Specific gravity.	Carbon, per cent.	Hydrogen, per cent.	Oxygen + nitrogen, per cent.	Sulphur, per cent.	Higher calorific value.	
						Calories, per gramme.	B.Th.U. per pound.
Russolene (H.Y.O.) . . .	0·890	85·95	13·50	—	0	10,900	19,600
American kerosene . . .	0·780	85·05	14·40	—	0	11,160	20,100
American royal daylight . . .	0·797	85·70	14·20	—	0	11,170	20,100
American petrol	—	80·58	15·10	4·31	0	11,080	19,950
Refined Russian petroleum (Baku)	0·825	86·00	14·00	—	—	11,270	20,290
American crude petroleum	—	86·90	13·10	—	—	10,910	19,650
Russian crude Caucasian (Novorossisk)	—	84·90	11·63	1·46	—	10,330	18,600
Baku heavy oil	—	86·70	12·94	—	—	10,800	19,450
Naphtha	—	75·57	10·57	3·91	—	9,250	16,650
Russian crude	0·871	86·90	13·10	—	0	10,830	19,500
Java crude	0·867	87·10	12·70	—	0	10,650	19,190
Canadian crude	0·859	86·92	12·87	—	0·35	10,800	19,450
Texas crude	0·947	86·62	11·80	—	0·63	10,520	18,960
Solar oil	0·896	86·61	12·60	—	0·30	10,780	19,430
Coal oil	0·917	83·20	11·87	—	1·56	10,220	18,410

EXAMPLE 1.—In a boiler trial the fuel analysis, dry coal as burned was C 83 per cent., H 4 per cent., Q 8 per cent., ash, etc., 5 per cent.; the volumetric analysis of the flue gases was CO₂ 10 per cent., CO 1·7 per cent., O 8·1 per cent., N 80·2 per cent. The temperature of the flue gases was 600° F. and of the boiler house 80° F. Find—

(1) The proportion of C burned to CO, and the heat lost through imperfect combustion, expressing the latter as a percentage of the heat in the fuel.

(2) The heat carried away in the flue gases per pound of fuel burned, the average specific heat being taken as 0·24.

In the example worked out in Art. 146, the proportion of C burned to CO was obtained from the analysis of the gases *by weight*. The proportion may be obtained directly from the volumetric analysis as follows:—

$$(1) \text{ C in 10 parts by volume of CO}_2 = 10 \times \frac{12}{44} \times \text{molecular weight of CO}_2 \\ = 10 \times \frac{12}{44} \times 44 = 120 \text{ parts}$$

$$\text{C in 1·7 " " CO} = 1·7 \times \frac{12}{28} \times \text{molecular weight of CO} \\ = 1·7 \times \frac{12}{28} \times 28 = 20·4 \text{ parts}$$

$$\text{Total carbon in gases} = 120 + 20·4 = 140·4 \text{ parts}$$

$$\text{Hence proportion of C burned to CO} = \frac{20·4}{140·4} = 0·1453 \text{ or } 14·53 \text{ per cent.}$$

and the heat lost through imperfect combustion per pound of coal

$$= 0·83 \times 0·1453(14,540 - 4400) = 1223 \text{ B.Th.U.}$$

¹ From a paper by the author on "The Calorific Values of Solid and Liquid Fuels," *The Engineer*, Feb. 17, 1911.

$$\begin{aligned} \text{Calorific value of the fuel by } \left. \begin{array}{l} \text{Dulong's formula} \\ \end{array} \right\} &= 14,540 \times 0.83 + 52,200(0.04 - 0.01) \\ &= 12,068 + 1566 \\ &= 13,634 \text{ B.Th.U. per pound.} \end{aligned}$$

$$\therefore \text{proportion lost through imperfect } \left. \begin{array}{l} \text{combustion} \\ \end{array} \right\} = \frac{1223}{13,634} = 0.089 \text{ or } 8.9 \text{ per cent.}$$

$$\begin{aligned} (2) \text{ Air supplied per pound of fuel by (3), } \left. \begin{array}{l} \text{Art. 144} \\ \end{array} \right\} &= \frac{80.2}{33(10 + 1.7)} \times 83 \\ &= 17.25 \text{ pounds} \end{aligned}$$

$$\begin{aligned} \therefore \text{weight of flue gases per pound of fuel} &= 17.25 + 0.95 \\ &= 18.2 \text{ pounds} \end{aligned}$$

$$\begin{aligned} \text{Heat carried away in flue gases } \left. \begin{array}{l} \text{per pound of fuel burned} \\ \end{array} \right\} &= 18.2 \times 0.24 (600 - 80) \\ &= 18.2 \times 0.24 \times 520 \\ &= 2271 \text{ B.Th.U.} \end{aligned}$$

EXAMPLE 2.—In a trial of a Lancashire boiler with economiser the following results were obtained:—

Volumetric analyses of the flue gases on entering and leaving the economiser—

	Entering.	Leaving.
CO ₂ . . .	8.3 per cent.	6.2 per cent.
CO	0.4 „	0.3 „
O	11.2 „	13.7 „
N	80.1 „	79.8 „
Total . .	100.0	100.0

Temperatures of the flue gases on entering and leaving the economiser, 642° F. and 335° F.

Temperatures of feed water on entering and leaving the economiser, 134° F. and 234° F.

Weight of feed water per hour, 7370 pounds.

Weight of coal stoked per hour, 1000 pounds.

Per pound of dry fuel stoked the carbon burned was 0.735 pound, and the weight of the flue gases, including moisture, entering the economiser was found to be 22.5 pounds.

The average specific heat of the gases may be taken as 0.25.

Calculate, per pound of fuel stoked—

(a) The air leakage into the economiser.

(b) The heat lost by the gases in passing through the economiser.

(c) The heat gained by the feed water. (L.U.)

$$(a) \text{ Total air per pound of fuel, } \left. \begin{array}{l} \text{by (3), Art. 144} \\ \end{array} \right\} = \frac{79.8}{33(6.2 + 0.3)} \times 73.5 = 27.34 \text{ pounds}$$

$$\text{Total weight of gases leaving } \left. \begin{array}{l} \text{economiser per pound of fuel} \\ \end{array} \right\} = 27.34 + 1 = 28.34 \text{ pounds}$$

$$\therefore \text{air leakage into economiser} = 28.34 - 22.5 = 5.84 \text{ pounds}$$

- (b) Heat lost by 22.5 pounds of gases $\left. \vphantom{\begin{matrix} (b) \\ \text{gases} \end{matrix}} \right\} = 22.5 \times 0.25(642 - 335)$
 $= 1727 \text{ B.Th.U.}$
- (c) Feed water per pound of fuel $= \frac{7370}{1000} = 7.37$ pounds
 \therefore heat gained by the water $= 7.37(234 - 134)$
 $= 737 \text{ B.Th.U.}$

N.B.—The amount of air that leaks into the economiser is, in its passage through the economiser, raised in temperature from the temperature of the boiler house to that of the gases leaving the economiser. The quantity of heat used for this purpose is of course wasted, and passes away in the flue gases, the efficiency of the economiser being thereby reduced.

In order to prevent air leakage through the brickwork, the walls enclosing the economiser should be built with hard-pressed bricks and cement. Glazed bricks are better still, and their extra cost would soon be recovered by the economy in fuel resulting from their use. If ordinary brickwork is used, it should be coated on the outside with pitch or other viscous substance to reduce porosity. The practice of encasing economisers with wrought-iron panelling, having 2 inches of asbestos yarn between the inner and outer plates, is sometimes followed; this, however, is an expensive remedy, but the heat saved, together with the greater facilities for access and repair, provides a reasonable return for the extra outlay.¹

148. Boiler Draught.—It is necessary to maintain a difference of pressure above and below the firegrate in order to supply the quantity of air required for combustion. This difference of pressure is known as the draught, and may be produced either by means of

- (a) A chimney (natural draught);
- (b) Steam jets (induced or forced draught);
- (c) Fans, which may either draw the gases from the flues (induced draught) or blow air under pressure into the ash-pit, or a closed boiler-room from which the air supply is drawn (forced draught).

The theoretical velocity of the gases produced by a draught or difference of pressure above and below the firegrate is given by the equation

$$v^2 = 2gl$$

where l is the height of a column of air, measured in feet, corresponding to the draught pressure.

Let h be the draught in inches of water.

Then, since a head of 1 inch of water is equivalent to a pressure of 5.198 pounds per square foot, and one cubic foot of air at N.T.P. weighs 0.0807 pound

$$l = \frac{5.198h}{0.0807}$$

$$\text{and } v^2 = 2 \times 32.2 \times \frac{5.198h}{0.0807}$$

$$v^2 = 4148h$$

$$v = \sqrt{4148h} \text{ feet per second} \quad \dots \dots (1)$$

¹ See the Author's "Steam Boilers." Edward Arnold.

The actual velocity of the gases will be less than that given by (1) because of the frictional resistance offered to their passage along the flues.

Height of Chimney required to produce a Given Draught.—

Let h = required draught in inches of water,
 H = height of chimney above the firegrate in feet,
 T_1 = absolute temperature inside the chimney (assumed constant),
 T_2 = absolute temperature outside the chimney
 n = number of pounds of air supplied per pound of fuel burned,
 A = cross-sectional area of chimney in square feet,

then the difference between the weight of a column of external air equivalent in volume to the interior of the chimney, and the weight of the same volume of the gases which are in the chimney, is equal to the draught pressure, *i.e.*

Weight of $A \times H$ cubic feet of external air — weight of $A \times H$ cubic feet of gases in chimney = $5.198h \times A$

$$\left(\frac{A \times H \times 0.0807 \times 492}{T_2} \right) - \left(A \times H \times \frac{n+1}{n} \times \frac{0.0807 \times 492}{T_1} \right) = 5.198h \times A$$

$$H \times 0.0807 \times 492 \left(\frac{1}{T_2} - \frac{n+1}{n} \cdot \frac{1}{T_1} \right) = 5.198h$$

$$H = \frac{5.198h}{0.0807 \times 492} \times \frac{nT_1T_2}{nT_1 - (n+1)T_2}$$

$$H = 0.13h \times \frac{nT_1T_2}{nT_1 - (n+1)T_2} \dots \dots \dots (2)$$

In the above theory the variation in the density due to the slightly reduced pressure inside the chimney is neglected, and if in addition we neglect the increased density due to the products of combustion, and assume the contents of the chimney to consist of air at atmospheric pressure

$$H = 0.13h \times \frac{T_1T_2}{T_1 - T_2} \dots \dots \dots (3)$$

and

$$h = \frac{H}{0.13} \left(\frac{1}{T_2} - \frac{1}{T_1} \right) \dots \dots \dots (4)$$

In actual practice the effect of the frictional resistance offered to the passage of the air through the firebars, fire, flues, and chimney is to reduce the draught h below the value obtained from equation (4); also, the temperature of the gases inside the chimney is diminishing for every foot of its height.¹ In other words, the height of chimney required to produce a given draught is greater than that given by equation (3).

Induced and Forced Draught.—With a plant properly designed for mechanical draught, greater economy in working may be obtained because complete combustion is possible with a lesser amount of air supplied per pound of fuel; and further, the gases can be cooled down to a much lower temperature before turning them off up the chimney than if chimney draught is used, and in addition the draught is under better

¹ For a more detailed account of practice see the Author's "Steam Boilers."

control. The B.H.P. of the engine driving a fan may be estimated as follows:—

Let V = volume of air or gases, in cubic feet, passing through the fan per minute,

h = draught pressure in inches of water,

η = efficiency of the fan,

n = number of pounds of air supplied per pound of fuel burned,

w = weight of fuel burned per second in pounds,

then
$$\text{B.H.P.} = \frac{5 \cdot 198 h \times V}{33,000 \times \eta} \dots \dots \dots (5)$$

With forced draught
$$V_f = 60nwV_0 \times \frac{T_f}{492}$$

where V_0 = volume of 1 pound of air at N.T.P. (12.39 cub. feet), and T_f = absolute temperature of the air delivered by the fan.

With induced draught there will be approximately $(n + 1)w$ pounds of flue gases delivered per second, and assuming the density to be the same as that of air

$$V_i = 60(n + 1)wV_0 \times \frac{T_i}{492}$$

$$\therefore \frac{\text{H.P. of induced draught fan}}{\text{H.P. of forced draught fan}} = \frac{60(n + 1)wV_0 \cdot T_i}{60nwV_0 \cdot T_f} = \frac{n + 1}{n} \times \frac{T_i}{T_f} \quad (6)$$

If air leakage through the brickwork be taken into account the ratio given by (6) will be further increased. The amount of leakage into the flues with induced draught will depend upon the intensity of the draught, and also upon the means taken to prevent it. With ordinary brickwork and no special precautions, the above ratio must be increased by about 20 per cent. with the result that the H.P. required for the induced draught fan will not be far from *double* that for the forced draught fan.

The advantages of using a mechanically produced draught may be briefly summed up as follows: Increased evaporation per square foot of heating surface; higher furnace temperatures and consequently increased efficiency; small chimneys may be used; cheaper coal can be economically burned; the easier regulation of the output of steam and the ability to meet sudden demands such as exist in electricity supply stations, rolling mills, warships, etc.; no dependence need be placed on the weather. The chief disadvantage of the system lies in the heavy upkeep and repairs that must be expected owing to the increased duty which the boilers are called upon to perform.

EXAMPLE.—Compare the fan powers expended for induced and forced draught. Compare also the quantity of heat carried away by the flue gases per pound of fuel burned in the following case:—

	Temp. of flue gases leaving boiler, ° F.	Air supplied per pound of fuel (pounds).	Temp. of air in boiler-house, ° F.
Induced draught .	350	18	62
Forced draught .	350	18	62
Chimney draught .	600	24	62

$$\begin{aligned} \therefore \text{heat evolved during combustion of CH}_4 & \left. \begin{aligned} &= 0.03354 \times 14,540 + 0.01118 \times 52,200 \\ &= 487.6 + 583.6 \\ &= 1071 \text{ B.Th.U. per cub. ft. at N.T.P.} \end{aligned} \right\} \end{aligned}$$

But the heat of formation of CH_4 is 17,100 calories per gram molecule, or 111 B.Th.U. per cubic foot. This amount will therefore be *absorbed* when burning CH_4 in decomposing it into C and H.

$$\begin{aligned} \text{Hence the lower calorific value of CH}_4 & \left. \begin{aligned} &= 1071 - 111 \\ &= 960 \text{ B.Th.U. per cubic foot at N.T.P.} \end{aligned} \right\} \end{aligned}$$

$$\text{Weight of C in 1 cubic foot of CO} = 0.07826 \times \frac{12}{28} = 0.03354 \text{ pound}$$

$$\begin{aligned} \therefore \text{calorific value of CO} &= 0.03354 \times 10,140 \\ &= 340 \text{ B.Th.U. per cubic foot at N.T.P.} \end{aligned}$$

$$\begin{aligned} \text{Hence lower calorific value of the sample of coal gas} & \\ &= 0.46 \times 282 + 0.395 \times 960 + 0.075 \times 340 \\ &= 129.7 + 389.2 + 25.5 \\ &= 544 \text{ B.Th.U. per cubic foot at N.T.P.} \end{aligned}$$

The calorific values as given by Professor F. W. Burstall of a few different combustible gases are given in the following table ¹ :—

Gas.	Calorific value in B.Th.U. per cubic foot.	
	Higher value.	Lower value.
Carbon monoxide CO . .	338	338
Hydrogen . . H ₂ . .	344	295.5
Methane . . . CH ₄ . .	1050	952.9
Olefiant gas . . C ₂ H ₄ . .	1670	—
Tetrylene . . C ₄ H ₈ . .	3060	—

EXAMPLE.—Using the above calorific values, estimate the calorific value of a producer gas of the following composition by volume: CO_2 7.66 per cent., CO 22.27 per cent., H_2 20.19 per cent., CH_4 2.778 per cent., O_2 0.04 per cent., N_2 47.06 per cent.

The tabular method is usually the most convenient for calculating the calorific value of a gas from its chemical analysis. Following the method explained above the results are as follows :—

¹ From the Third Report to the Gas Engine Research Committee, *Proc. I. Mech. E.*, 1908, p. 26.

Gas.	Per-centage of gas.	Heating value per cubic foot of each constituent.		Heating value per cubic foot of mixture.	
		B.Th.U. Higher value.	B.Th.U. Lower value.	B.Th.U. Higher value.	B.Th.U. Lower value.
Carbon dioxide CO ₂ .	7'66	—	—	—	—
Carbon monoxide CO .	22'27	338	338	75'28	75'28
Hydrogen . . . H ₂ .	20'19	344	295'5	69'45	59'67
Methane . . . CH ₄ .	2'778	1,050	952'9	29'17	26'47
Oxygen . . . O ₂ .	0'04	—	—	—	—
Nitrogen . . . N ₂ .	47'06	—	—	—	—
Totals				173'9	161'4

The actual values as obtained by Junker's calorimeter were—

Higher value, 175'6 B.Th.U. per cubic foot.

Lower value, 162'0 B.Th.U. per cubic foot.

150. Producer Gas, Theory.—Producer gas is made by forcing or drawing air (with or without the addition of steam) through a deep bed of fuel in a closed producer. In a suction gas-producer the air is drawn through by the suction of the engine piston, and in all cases, when once the burning of the fuel inside the producer has been started, the partial combustion is maintained by the air supply, and a sufficiently high temperature kept up to decompose the steam and to effect other reactions.

If there were a thin fire in the producer the carbon and other combustible elements of fuel would be completely oxidized and the products would be incombustible, and therefore useless as a fuel. In practice a considerable depth of fuel is used (several feet), and there will be an excess of incandescent carbon which will reduce the CO₂ formed at the bottom of the fire where the air enters to CO according to the equation



Carbon monoxide may also be produced by the direct combination of carbon with oxygen, thus—



Both these reactions may and probably do occur in an actual producer, and if gas is made by simply passing air through a thick fire the final result aimed at is to have the carbon oxidised to CO only. Each pound of carbon so burned gives out (as we have already seen) 4400 B.Th.U., the remaining 14,540—4400 or 10,140 B.Th.U. being available in the carbon contained in the CO present in the producer gas. The 10,140 B.Th.U. is practically 70 per cent. of the heat in the carbon to start with, the remaining 30 per cent. (4400 B.Th.U.) being expended in keeping the fire alight and maintaining a high temperature; this means that if there are no heat losses the efficiency of the producer will be 70 per cent.

The 30 per cent. of the heat in the fuel need not, however, be entirely lost. A certain amount (say 8 per cent.) will be lost through radiation and conduction, but a large proportion will be carried away with the gas as

sensible heat, since the gas will leave the producer at a high temperature ; and if the gas can be used while it is hot not much of this sensible heat will be lost. The high temperature obtained in the producer with this sensible heat may be excessive and cause trouble in working by the formation of clinker which will obstruct the air passages. To avoid the production of too high a temperature and also to increase the efficiency of the producer (*i.e.* to reduce the 30 per cent. loss) some of the sensible heat may be used to generate steam to be passed in the producer with the air. This steam may react on the carbon in the following ways :—

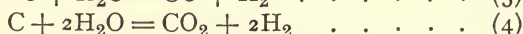
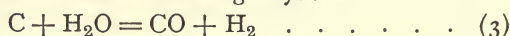

Both these reactions cause a large absorption of heat, the former (3) to the extent of 4300 B.Th.U. per pound of carbon, and the latter to that of 2820 B.Th.U., so that each of them has the practical advantage of reducing the temperature of the producer, and in addition they increase the calorific value of the gas by the addition of hydrogen.

At temperatures above 1832° F. (1000° C.) reaction (3) is more likely to occur ; but at a temperature of 1112° F. (600 C.) and under, reaction (4) takes place ; while at temperatures between 1112 F. and 1832° F. the two take place simultaneously, the predominance of either being entirely a function of the temperature.¹ It is evident that since equation (3) gives the richer gas and the greater absorption of heat, the best results will be obtained in practice when working at the highest temperature consistent with practical conditions.

The proportion of steam which should be used to obtain gas of the highest calorific value can be determined theoretically as below, but this in practice is largely affected by the nature and composition of the fuel used and the size of the producer. It varies from 0.5 pound for large producers to 0.7 pound for small producers per pound of coal gasified.² The best thickness of fuel depends upon the size of the pieces, but for ordinary anthracite as used in producers, from 2 to 3 feet seems to give the best results according to Mr. Allcut, Mr. Dowson, and Dr. Bone and Dr. Wheeler.³

Theoretical Amount of Steam required per Pound of Fuel to give Maximum Efficiency.—Assume that the reactions given in (2) and (3) are followed,



$$24 + 32 = 56$$

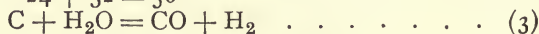

$$12 + 18 = 28 + 2$$

From (2), 24 pounds of carbon liberate $24 \times 4400 = 105,600$ B.Th.U.

From (3), 12 pounds of carbon are required to dissociate 18 pounds of steam, the reaction *absorbing* $4300 \times 12 = 51,600$ B.Th.U.

Now the H₂O is supplied to the producer as water, not as steam, and assuming the temperature of supply to be 62° F., the amount of heat

¹ See "Producer Gas," by Dowson and Larter, p. 55.

² See the following papers: *Proceedings Inst. Mech. Eng.*, 1911, "Gas Producers" by J. Emerson Dowson, and "Effect of Varying Proportions of Air and Steam on a Gas Producer," by E. A. Allcut.

³ *Journal Iron and Steel Institute*, No. III., 1908, p. 206.

required to generate 1 pound of steam at atmospheric pressure from water at 62° F. will be

$$(212 - 62) + 970 = 1120 \text{ B.Th.U.}$$

Now 18 pounds of steam are dissociated by 12 pounds of carbon, hence this reaction will absorb

$$51,600 + 18 \times 1120 = 71,760 \text{ B.Th.U.}$$

$$\therefore \text{amount of water required} = 18 \times \frac{105,600}{71,760} = 26.48 \text{ pounds}$$

The amount of carbon required for this weight of H₂O will be 24 pounds, which follow reaction (2), and $12 \times \frac{26.48}{18} = 17.65$ pounds, which follow reaction (3), giving a total of 41.65 pounds.

$$\therefore \text{weight of water per pound of carbon} = \frac{26.48}{41.65} = 0.63 \text{ pound}$$

If the reaction (4) is followed,

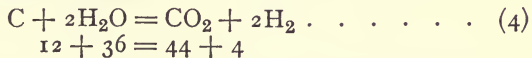

12 pounds of carbon are required to dissociate 36 pounds of steam the reaction *absorbing* $4300 \times 12 = 51,600$ B.Th.U.; adding to this the heat of evaporation of 36 pounds of steam from water at 62° F., the total amount absorbed will be

$$51,600 + 36 \times 1120 = 91,920 \text{ B.Th.U.}$$

$$\therefore \text{amount of water required} = 36 \times \frac{105,600}{91,920} = 41.35 \text{ pounds}$$

The corresponding amount of carbon will be

$$24 + 12 \times \frac{41.35}{36} = 37.78 \text{ pounds}$$

$$\therefore \text{weight of water per pound of carbon} = \frac{41.35}{37.78} = 1.09 \text{ pounds}$$

Analysis of the Producer Gas.—Assuming reactions (2) and (3), 24 pounds of carbon follow (2) and 17.65 pounds follow (3), hence,

From (2) 24 pounds of C yield 56 pounds of CO.

Now the weight of 1 cubic foot of CO = $14 \times 0.00559 = 0.07826$ pounds (Art. 149).

$$\therefore 24 \text{ pounds of C yield } \frac{56}{0.07826} = 715 \text{ cubic feet of CO at N.T.P.}$$

From (3), 17.65 pounds of C yield $28 \times \frac{17.65}{12}$ pounds of CO

$$= \frac{28 \times 17.65}{12 \times 0.07826} = 526 \text{ cubic feet of CO at N.T.P.}$$

From (3) 17.65 pounds of C yield

$$2 \times \frac{17.65}{12} \times \frac{1}{0.00559} = 526 \text{ cubic feet of CO at N.T.P.}$$

From (2) the total amount of O supplied = 32 pounds

$$= \frac{32}{16 \times 0.00559} = 357 \text{ cubic feet at N.T.P.}$$

and since air contains 79 per cent. by volume of nitrogen, the amount of N supplied in the air with 357 cubic feet of O will be

$$357 \times \frac{79}{21} = 1343 \text{ cubic feet at N.T.P.}$$

The total will therefore consist of

$$\begin{array}{r} \text{CO} = 715 + 526 = 1241 \text{ cubic feet} = 39.9 \text{ per cent.} \\ \text{H}_2 = 526 \quad \text{,,} \quad \text{,,} = 16.9 \quad \text{,,} \\ \text{N}_2 = 1343 \quad \text{,,} \quad \text{,,} = 43.2 \quad \text{,,} \\ \hline \text{Total} = 3110 \qquad \qquad \qquad 100.0 \end{array}$$

The above analysis might be worked out more conveniently in C.G.S. system of units. Since the molecular weight of any gas occupies 22.25 litres (see Introduction, p. xii),

From (2), 24 grams of C yield $2 \times 22.25 = 44.5$ litres of CO at N.T.P.

From (3), 17.65 grams of C yield $22.25 \times \frac{17.65}{12} = 32.7$ litres of CO at N.T.P.

From (3), 17.65 grams of C yield $22.25 \times \frac{17.65}{12} = 32.7$ litres of H₂ at N.T.P.

From (2), O supplied = 22.25 litres

$$\therefore \text{N}_2 \text{ supplied} = 22.25 + \frac{79}{21} = 83.7 \text{ litres of N}_2 \text{ at N.T.P.}$$

The total therefore will consist of

$$\begin{array}{r} \text{CO} = 44.5 + 32.7 = 77.2 \text{ litres} = 39.9 \text{ per cent.} \\ \text{H}_2 = 32.7 \quad \text{,,} = 16.9 \quad \text{,,} \\ \text{N}_2 = 83.7 \quad \text{,,} = 43.2 \quad \text{,,} \\ \hline \text{Total} = 193.6 \quad \text{,,} = 100.0 \quad \text{,,} \end{array}$$

The lower calorific value of the gas per cubic foot at N.T.P. will therefore be—

$$\text{CO} = 0.399 \times 340 = 135.6 \text{ B.Th.U.}$$

$$\text{H}_2 = 0.169 \times 282 = 47.6$$

$$\text{Total} = 183.2 \text{ B.Th.U. per cubic foot.}$$

EXAMPLES XI

1. The analysis by weight of a certain coal is C 80 per cent., H₂ 5 per cent., S 0.5 per cent.; estimate the theoretical quantity of air required for the complete combustion of 1 pound of the coal. If 20 pounds of air are supplied per pound of coal and the combustion is complete, estimate the analysis of the flue gases by weight.

2. A producer gas has the following analysis by volume: H₂ 18.73 per cent., CO 25.07 per cent., CO₂ 5.2 per cent., N₂ 51 per cent. Estimate the minimum quantity of air required for the complete combustion of 1 cubic foot of the gas, the percentage contraction in volume after combustion, and the composition of the products of combustion.

3. The analysis (by weight) of the fuel used in a boiler trial was C 88 per cent., H₂ 3.6 per cent., O₂ 4.8 per cent., ash 3.6 per cent., and the volumetric analysis of the dry flue gases was CO₂ 10.9 per cent., CO 1.0 per cent., O₂ 7.1 per cent., N₂ 81 per cent. Estimate the mean specific heat of the flue gases, and the quantity of heat carried away by the flue gases per pound of fuel burned if the temperature of the gases is 550° F., and of the air in boiler house 50° F.

4. The flue gas analysis by volume in a boiler trial was CO₂ 10.5 per cent., CO 1 per cent., O₂ 8 per cent., N₂ 80.5 per cent., and the coal analysis as burned was C 82 per cent., H₂ 4.2 per cent., O₂ 4.8 per cent., other matters 9 per cent. Calculate the following

items in the heat balance per pound of coal, the temperature of the flue gases being 600°F . and the temperature of the air supply 60°F :—

- (a) Heat carried away by products of combustion, average specific heat 0.24 .
- (b) Heat carried away by excess air, average specific heat 0.238 .
- (c) Heat lost by incomplete combustion.

5. In a boiler trial the fuel analysis, dry coal as burned, was C 85 per cent., H_2 4 per cent., O_2 7 per cent., ash, etc., 4 per cent., and the flue gas analysis by weight was CO_2 11 per cent., CO 1.5 per cent., O_2 7.1 per cent., N_2 80.4 per cent. The temperature of the flue gases leaving the boiler was 600°F ., and the boiler house temperature was 70°F . Estimate per pound of coal—

- (a) The proportion of carbon burned to CO and the heat lost through this imperfect combustion, expressing the latter as a percentage of the available heat in the fuel.
- (b) The heat carried away in the flue gases per pound of coal burned, the mean specific heat of the flue gases being taken as 0.24 .

6. In a trial on a Babcock and Wilcox boiler fitted with an economiser the following volumetric analyses of the gases entering and leaving the economiser were made :—

	Leaving	Entering
CO_2 . . .	7.9 per cent.	8.3 per cent.
CO . . .	nil	nil
O_2 . . .	11.5	11.4
N_2 . . .	80.6	80.3

The temperatures of the flue gases on entering and leaving the economiser were 350°C . and 180°C . respectively. Temperatures of water on entering and leaving economiser were 15°C . and 115°C . Weight of feed water per hour 10,000 pounds, weight of coal used per hour 1060 pounds. Carbon in 1 pound of coal 0.8 pound. Assuming the average specific heat of the gases to be 0.25 , estimate per pound of coal burned—

- (a) The air leakage into the economiser.
- (b) The heat lost by the gases in passing through the economiser.
- (c) The heat gained by the feed water.

7. Estimate the minimum height of chimney required to produce a draft of $\frac{1}{8}$ inch of water if 24 pounds of air are supplied per pound of fuel burned, the mean temperature of the gases inside the chimney being 600°F . and the temperature of the external air 80°F .

8. Estimate the B.H.P. of the engine required to drive a fan which maintains a draught of 2 inches of water under the following conditions for—

- (a) Induced draught fan ;
- (b) Forced draught fan.

Temperature of flue gases leaving the boiler in each case 400°F ., and of the air in the boiler house 70°F . ; air supplied per pound of fuel in each case 18 pounds ; weight of coal burned per hour in each case 2000 pounds.

Neglect the effect of air leakage through the brickwork and assume the efficiency of the fan to be 80 per cent.

9. A sample of coal gas has the following analysis by volume : H_2 46 per cent., marsh gas CH_4 39.5 per cent., olefiant gas C_2H_4 2.53 per cent., tetrylene C_4H_8 1.27 per cent., CO 7.5 per cent., N_2 0.5 per cent., water vapour H_2O 2 per cent. Calculate

- (a) The volume of air required for the complete combustion of 1 cubic foot of the gas.
- (b) The higher calorific value in B.Th.U. per cubic foot.
- (c) The lower calorific value in B.Th.U. per cubic foot.

Assume the calorific values of the above constituents the same as given in the table on page 250.

10. The gas used in a gas engine test was tested in a Junker calorimeter and the following results were obtained :—

Gas burned in calorimeter	2.13 cubic feet
Pressure of gas supplied	2.1 inches of water
Barometer	29.92 inches of mercury
Temperature of gas	53°F . (11.7°C .)
Weight of water heated by gas	50.3 pounds
Temperature of water at inlet	47.6°F . (8.7°C .)
Temperature of water at outlet	72.4°F . (22.4°C .)
Steam condensed during test	0.116 pound

Determine the higher and lower calorific values per cubic foot at the temperature of 60° F. (15.6° C.) and barometric pressure of 30 inches of mercury. [Specific gravity of mercury = 13.6.]

11. A sample of oil used in an oil engine trial was tested in a Mahler-Cook bomb calorimeter and the following results were obtained :—

Weight of oil taken = 1.090 grams.

Total weight of water, including water equivalent of calorimeter, 2800 grams.

Corrected rise of temperature of the water = 4.26° C.

Determine the higher calorific value of the oil.

12. Find the maximum efficiency of a suction gas producer, the composition of the gas produced, and the calorific value per cubic foot, assuming that the fuel is carbon and that only air is passed through the fuel; given that one pound of hydrogen occupies 178.8 cubic feet; that the calorific value of carbon monoxide is 342.4 B.Th.U. (190.2 C.H.U.) per cubic foot; and that the calorific value of 1 pound of carbon is 14,544 B.Th.U. (8080 C.H.U.). What is the effect of admitting steam in addition to the air (*a*) on the working; (*b*) on the efficiency of the producer? (L.U.)

13. The volumetric analysis of a producer gas supplied to an engine is CO_2 7.66 per cent., CO 22.27 per cent., H_2 20.19 per cent., CH_4 2.778 per cent., N_2 47.1 per cent. The exhaust gases contained 10 per cent. of oxygen by volume. Estimate the quantity of air actually supplied per cubic foot of gas and the contraction in volume in the engine cylinder due to combustion.

CHAPTER XII

HEAT TRANSMISSION

151. Transmission through Flat Plates.—When the opposite sides of a flat plate of infinitely large area are maintained at two different constant temperatures the amount of heat conducted through the plate is

$$H = k \times \frac{t_1 - t_2}{x} \text{ B.Th.U. per square foot per hour} \quad (1)$$

where t_1 and t_2 denote the temperatures ($^{\circ}$ F.) of the two sides of the plate, x the thickness of the plate in inches, and k the thermal conductivity of the plate, *i.e.* the number of B.Th.U. passing per hour through one square foot of a plate 1 inch in thickness when the sides are kept at a constant difference of temperature of 1° F. The value of this constant for wrought iron and mild steel is 450.

Assuming the temperature of the gas side of a steel plate 0.5 inch thick to be, say, 1500° F. and that of the water side 400° F., the above formula will give

$$\begin{aligned} H &= 450 \times \frac{1500 - 400}{0.5} \\ &= 990,000 \text{ B.Th.U. per square foot per hour} \end{aligned}$$

Applying this to a boiler heating surface, the equivalent evaporation from and at 212° F. will be

$$\frac{990,000}{966} = 1020 \text{ pounds per square foot per hour.}$$

Now in actual practice an average evaporation of only about 5 pounds is obtained, corresponding to a transmission of only about 5000 B.Th.U. per square foot per hour, which would be obtained if the difference in temperature of the two sides of the plate was about 5.5° F. The difficulty attending the use of this simple formula lies in our uncertainty as to the temperatures on the two sides of the plate, the temperature head across the plate being *very* much less than the difference between the temperatures of the hot gases and the water.

From the results of numerous experiments *Rankine* gave the following empirical formula for the heat transmitted per square foot per hour :—

$$H = \frac{(t_1 - t_2)^2}{a} \text{ B.Th.U. per square foot per hour} \quad (2)$$

where a is a constant varying from 160 to 200 depending upon the type of boiler, t_1 and t_2 the temperatures of the *gases* and *water* respectively.

Taking $a = 200$, this formula applied to the above case gives

$$H = \frac{(1500 - 400)^2}{200} = 6050 \text{ B.Th.U. per square foot per hour}$$

If now (1) be applied to this result it is evident that

$$6050 = \frac{450(t_1 - t_2)}{0.5}$$

or

$$t_1 - t_2 = 6.7^\circ \text{ F.}$$

The temperature of the water side of the plate will not be very much above that of the water; suppose it to be 430° F. , then the temperature of the gas side of the plate will be about 437° F. , say 440° F. , according to the above result, and the drop in temperature between the hot gases and the plate will be $1500 - 400 = 1100^\circ \text{ F.}$ The results of experiments by Mr. Hudson¹ and Sir John Durston² confirm this conclusion and show that the actual temperature head across a boiler heating surface is but a very small proportion of the difference of temperature between the hot gases and the water.

152. Efficiency of Heating Surface.—Consider the case in which the gases pass along inside a cylindrical tube of diameter d and length l which is surrounded by water.

- Let T_1 = absolute temperature of the gases entering the tube.
- T_2 = " " " " leaving "
- θ = " " " water.
- w = weight of gases passing along the tube per second.
- s = specific heat of the gases.

Further, let T be the absolute temperature of the gases at a distance x from the inlet end of the tube (Fig. 122) assumed constant over a small length

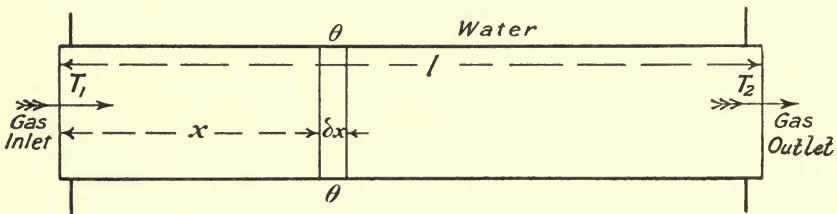

FIG. 122.

δx of the tube, then, if Q denotes the amount of heat transmitted through the tube per square foot per second per degree of difference in temperature on the two sides, we have, assuming the heat transmitted to be proportional to the temperature difference on the two sides of the plate,

$$-ws\delta T = Q(T - \theta)\pi d\delta x \dots \dots (1)$$

where δT = fall in temperature of the gases in moving δx along the tube.

¹ *Engineer*, vol. 70, p. 523, 1890.
² *Trans. Inst. Naval Arch.*, vol. 34, p. 130, 1898.

$$\therefore \frac{\delta T}{T - \theta} = - \frac{Q\pi d}{ws} \cdot dx$$

or
$$\frac{dT}{T - \theta} = - \frac{Q\pi d}{ws} dx \dots \dots \dots (2)$$

Integrating (2) we have

$$\int_{T_1}^{T_2} \frac{dT}{T - \theta} = - \int_0^l \frac{Q\pi d}{ws} dx$$

$$\log_e \frac{T_2 - \theta}{T_1 - \theta} = - \frac{Q\pi d}{ws} \cdot l \dots \dots \dots (3)$$

$$\frac{T_2 - \theta}{T_1 - \theta} = e^{-\frac{Q\pi d}{ws} \cdot l} \dots \dots \dots (4)$$

Available heat entering the tube per second = $ws(T_1 - \theta)$

„ „ leaving „ „ „ = $ws(T_2 - \theta)$

$$\therefore \text{efficiency} = \frac{ws(T_1 - T_2)}{ws(T_1 - \theta)}$$

$$= \frac{T_1 - T_2}{T_1 - \theta} \dots \dots \dots (5)$$

$$= 1 - \frac{T_2 - \theta}{T_1 - \theta} \dots \dots \dots (6)$$

(4) in (6) gives

$$\text{efficiency} = 1 - e^{-\frac{Q\pi d}{ws} \cdot l} \dots \dots \dots (7)$$

From (7) we see that for a given length of tube and a given weight of gases passing per second the efficiency decreases as the diameter of the tube *decreases*.

Equation (7) may be expressed in terms of the velocity of the gases as follows:—

Let v = speed of the gases,
 ρ = density of the gases,

then
$$w = v \times \frac{\pi d^2}{4} \times \rho$$

and
$$\frac{Q\pi d}{ws} \cdot l = \frac{4Q}{svd\rho} \cdot l$$

hence
$$\text{efficiency} = 1 - e^{-\frac{4Q}{svd\rho} \cdot l} \dots \dots \dots (8)$$

For a given diameter and length of tube it is evident from (8) that the efficiency will decrease as the velocity v *increases*. This is also evident from (7), since by decreasing the diameter the velocity will increase for a given weight of gases passing through the tube. This conclusion, however, is not confirmed by experiment. On the contrary, the heat transmission is found to *increase* as the velocity increases, and small tubes are more efficient than large ones (see Arts. 156 and 158).

Case when the Heat transmitted is Proportional to the Square of the Difference of Temperature.—In this case

Let T_1 = difference of temperature between gases and water at entrance to the tube,

T_2 = difference of temperature between gases and water leaving the tube,

T = difference of temperature between the gases and water at a point x from the inlet end of the tube.

We have

$$-ws\delta T = QT^2 \cdot \pi d\delta x \dots \dots \dots (9)$$

$$-\frac{dT}{T^2} = + \frac{Q\pi d}{ws} dx$$

$$\therefore \int_{T_1}^{T_2} -\frac{dT}{T^2} = \int_0^l \frac{Q\pi d}{ws} dx$$

$$\frac{1}{T_2} - \frac{1}{T_1} = \frac{Q\pi dl}{ws}$$

Writing the internal area of the tube $\pi dl = A$

$$\frac{1}{T_2} - \frac{1}{T_1} = \frac{QA}{ws} \dots \dots \dots (10)$$

from which

$$\frac{T_2}{T_1} = \frac{1}{\frac{QAT_1}{ws} + 1}$$

Available heat entering the tube per second = wsT_1

„ „ leaving „ „ „ = wsT_2

$$\therefore \text{efficiency} = \frac{ws(T_1 - T_2)}{wsT_1}$$

$$= 1 - \frac{T_2}{T_1} \dots \dots \dots (11)$$

(10) in (11) gives

$$\text{efficiency} = 1 - \frac{1}{\frac{QAT_1}{ws} + 1}$$

$$= \frac{1}{1 + \frac{ws}{QAT_1}} \dots \dots \dots (12)$$

$$= \frac{1}{1 + (w \times \text{constant})}$$

or, if W pounds of coal are burned per second and the air supplied per pound of coal is constant

$$\text{efficiency} = \frac{1}{1 + cW} \dots \dots \dots (13)$$

where c is a constant

If now the net amount of heat evolved per pound of fuel be constant and equal to H , then the total per second will be WH .

Let x be the equivalent evaporation from and at 212° F. per second, then from (13)

$$x = \frac{1}{1 + cW} \times \frac{WH}{970} \text{ approximately (14)}$$

If y denotes the equivalent evaporation from and at 212° F. per pound of coal, then

$$y = \frac{x}{W} = \frac{H}{(1 + cw)970} \text{ (15)}$$

From (14) $\frac{WH}{970} = (1 + cW)x$

$$\therefore W = \frac{1}{\frac{H}{970x} - c}$$

or $\frac{1}{W} = \frac{H}{970x} - c$

\therefore From (15) $y = \frac{x}{W} = \frac{H}{970} - cx \text{ (16)}$

Hence, if the above theory be accepted, the equivalent evaporation from and at 212° F. per pound of fuel is a linear function of the total equivalent evaporation per second or per hour.

153. Transmission through the Walls of a Thick Tube.—

Let l be the length of the tube, r_1 and r_2 the internal and external radii respectively, T_1 the temperature of the inside surface and T_2 the temperature of the outside surface, then if

Q = heat transmitted across 1 square foot of any surface per second per degree difference in temperature

H = total heat transmitted across the inside surface of the tube per second

$$Q = -K \frac{dT}{dx} \text{ (Art. 68) (1)}$$

Across the surface of radius $r_1 + x$

$$Q = \frac{H}{2\pi(r_1 + x)l} \text{ (2)}$$

\therefore From (1) and (2)

$$\frac{dT}{dx} = - \frac{H}{2\pi K(r_1 + x)l}$$

$$\frac{dT}{dx} = - \frac{H \times r_1}{2\pi K(r_1 + x)lr_1}$$

Integrating over the whole length of the tube, we have

$$\int_{T_2}^{T_1} dT = - \frac{Hr_1}{2\pi Klr_1} \int_{r_2-r_1}^0 \frac{dx}{r_1 + x}$$

$$T_1 - T_2 = \frac{Hr_1}{2\pi Klr_1} \cdot \log_{\epsilon} \frac{r_2}{r_1}$$

$$\therefore H = \frac{(T_1 - T_2)2\pi r_1 K l}{r_1 \log_e \frac{r_2}{r_1}} \dots \dots \dots (3)$$

$$= \frac{(T_1 - T_2)AK}{r_1 \log_e \frac{r_2}{r_1}} \dots \dots \dots (4)$$

where A is the internal area of the tube.

154. Effect of High Gas Speed upon Conduction.—The formulæ given above assume that the temperature of the gas side of the plate is the same as that of the gases, and further, no account is taken of the density of the gases nor of the velocity with which they sweep over the heating surface. The great drop in temperature between the hot gases and the plate (Art. 151) may be accounted for if we accept the existence of a film of gas which clings to the plate. Gases transmit heat chiefly by convection, being very bad conductors of heat, and evidently, the greater the thickness of this stationary gas film, the greater will be the drop in temperature between the gases flowing over the heating surface and the metal plate. Experiment shows that this gas film does exist, and also brings forward considerable evidence to show that a thin film of water clings to the water side of the heating surface.

Professor Dalby¹ suggests that of the total temperature head between the hot gases and water, about 97 per cent. is required to overcome the resistance of the gas film, 1 per cent. to overcome the resistance of the plate, and 2 per cent. to overcome the resistance of the water film. From this it is evident that the material of which the heating surface is constructed makes very little difference to the transmission of heat; and further, that the thickness of the plates has a negligibly small effect.

The velocity of the gases flowing along a furnace or smoke tube will not be uniform at all points of the cross section of the tube, the flow near the centre of a tube of large diameter (such as the furnace tube of a Lancashire boiler) being of a turbulent nature, the velocity diminishing towards the surface. The greater the speed of the gases and the smaller the diameter of the tube the thinner will be the gas film adhering to the heating surface, and the higher will be the temperature on the gas side of the plate, resulting in an increased temperature head across the plate, and consequently in an increased amount of heat transmitted.

Professor Osborne Reynolds in 1874 deduced from theoretical considerations that the amount of heat transmitted was a linear function of the speed of the fluids. He gave the following formula for the amount of heat passing from the gases to the heating surface:—

$$Q = (A_1 + B_1 \rho_1 \mu_1)(T - \theta) \dots \dots \dots (1)$$

where Q = B.Th.U. transmitted per square foot per second,
 ρ_1 = density of the gases in pounds per cubic foot,
 μ_1 = velocity of the gases in feet per second,
 T = temperature of the gases in ° F.,
 θ = mean temperature of the heating surface,
 A_1 and B_1 = constants.

¹ "Heat Transmission," Inst. Mech. Eng., Oct., 1909, p. 939.

In 1897, Dr. T. E. Stanton showed that the above law held for water on opposite sides of a metal plate; ¹ the law may be written

$$Q = (A_1 + B_1\rho_1\mu_1)(T - \theta) = (A_2 + B_2\rho_2\mu_2)(\theta - t) \quad (2)$$

where ρ_2 = density of water in pounds per cubic foot,
 μ_2 = velocity of the water in feet per second,
 t = temperature of the water in ° F.,

A_2 and B_2 = constants.

The above law has been since verified by many notable experimenters, but for a detailed account of the researches which have been made on "Heat Transmission," the reader is referred to the paper by Professor Dalby ² already mentioned.

Mr. Hudson, ³ in 1890, gave the following expression for the heat transmitted through boiler tubes or flues per hour per square foot per degree Fahrenheit:—

$$\frac{T_g + T_s + 922}{2} \times \frac{\sqrt{v}}{B}$$

where T_g = absolute temperature of the flue gases ° F.
 T_s = " " " " steam ° F.
 v = velocity of the gases in feet per second,
 B = a constant.

155. Heat transmitted through a Cylindrical Tube in Terms of the Gas Temperature, and the Temperature of the Gas Side of the Tube.

Let w_1 = weight of gases flowing through the tube per second.

s = specific heat of the gases.

Q = heat transmitted per second per square foot per degree Fahrenheit difference of temperature of air and metal.

d = diameter of tube.

T_1 = temperature of gases at inlet end of tube.

θ_1 = " metal " "

T_2 = " gases at outlet end of tube.

θ_2 = " metal " "

Consider an element of the tube of length δx distant x from the inlet end, where the temperature of the metal surface is θ° F., and over which the fall in temperature of the gases is δT , their temperature being T .

Then
$$-ws\delta T = Q \times \pi d(T - \theta)\delta x \quad \dots \quad (1)$$

Now
$$\theta = \theta_1 - \frac{d\theta}{dx} \cdot x$$

Assuming a uniform temperature gradient along the tube, this becomes

$$\theta = \theta_1 - cx \quad \dots \quad (2)$$

¹ *Trans. Royal Society*, vol. cxcix., 1897, pp. 67-88.

² *Proceedings Inst. Mech. Engineers*, Oct., 1909.

³ *Engineer*, vol. 70, p. 523, 1890.

(2) in (1) gives

$$\begin{aligned}
 -ws\delta T &= Q \cdot \pi d \{T - (\theta - cx)\} \delta x \\
 -\frac{\delta T}{\delta x} &= \frac{Q \cdot \pi d}{ws} \{T - (\theta_1 - cx)\} \\
 \therefore -\frac{dT}{dx} &= \frac{Q\pi d}{ws} \cdot T - \frac{Q\pi d}{ws} (\theta_1 - cx) \dots (3)
 \end{aligned}$$

Writing

$$\begin{aligned}
 P &= \frac{Q\pi d}{ws} \text{ (3) becomes} \\
 -\frac{dT}{dx} &= PT - P(\theta_1 - cx)
 \end{aligned}$$

or

$$\frac{dT}{dx} + PT = P(\theta_1 - cx) \dots (4)$$

The integrating factor of (4) is $e^{-\int P dx} = e^{-Px}$. To obtain a particular integral write¹

$$T = ue^{-Px}$$

Then $\frac{du}{dx} e^{-Px} = P(\theta_1 - cx)$

$$\begin{aligned}
 \frac{du}{dx} &= P(\theta_1 - cx)e^{Px} \\
 \therefore u &= P\theta_1 \int e^{Px} dx - cP \int x e^{Px} dx + A \\
 &= \frac{P\theta_1}{P} e^{Px} - cxe^{Px} + \frac{c}{P} e^{Px} + A \\
 \therefore T &= e^{-Px} \left(\theta_1 e^{Px} - cxe^{Px} + \frac{c}{P} e^{Px} + A \right) \dots (5)
 \end{aligned}$$

When

$$\begin{aligned}
 x = 0, T &= T_1 \\
 \therefore T_1 &= \frac{c}{P} + \theta_1 + A, \therefore A = T_1 - \frac{c}{P} - \theta_1
 \end{aligned}$$

\(\therefore\) (5) becomes

$$\begin{aligned}
 T &= e^{-Px} \left[\theta_1 e^{Px} - cxe^{Px} + \frac{c}{P} e^{Px} + T_1 - \theta_1 - \frac{c}{P} \right] \\
 T &= e^{-Px} \left[T_1 - \theta_1 - \frac{c}{P} \right] + \theta_1 - cx + \frac{c}{P} \dots (6)
 \end{aligned}$$

At the outlet end of the tube where $x = l, T = T_2$

$$\therefore \text{from (6)} \quad T_2 = e^{-Pl} \left[T_1 - \theta_1 - \frac{c}{P} \right] + \theta_1 - cl + \frac{c}{P} \dots (7)$$

But from (2)

$$\begin{aligned}
 \theta_1 - cl &= \theta_2 \\
 \therefore T_2 &= e^{-Pl} \left[T_1 - \theta_1 - \frac{c}{P} \right] + \theta_2 + \frac{c}{P} \\
 \therefore e^{-Pl} &= \frac{T_2 - \theta_2 - \frac{c}{P}}{T_1 - \theta_1 - \frac{c}{P}} \dots (8)
 \end{aligned}$$

¹ See Lamb's "Infinitesimal Calculus," p. 515.

or
$$Pl = \log_e \frac{T_1 - \theta_1 - \frac{c}{P}}{T_2 - \theta_2 - \frac{c}{P}} \dots \dots \dots (9)$$

Solving (9) for P, and then putting $P = \frac{Q \cdot \pi d}{ws}$ enables Q to be found.

If H = total heat transmitted through the tube per second, the mean difference of temperature of the gases and tube will be

$$T - \theta = \frac{H}{SQ} \dots \dots \dots (10)$$

where S = total surface of inside of tube.

The approximate mean temperature of the more or less stationary film of gas adhering to the tube will be $\frac{T + \theta}{2}$.

156. Other Forms of Reynolds's Law.—Professor Reynolds's law for heat flow (Art. 154, Eq. (1)) may be written

$$Q = A + B \frac{w}{a} \text{ B.Th.U. per square foot per second per degree difference of temperature} \dots \dots \dots (1)$$

where w is the weight of gases flowing per second, and a is the cross-sectional area of the channel.

Mr. H. P. Jordan¹ has carried out numerous experiments in which hot air was passed through a copper pipe surrounded by a cast-iron casing, the annular space between the two forming a water-jacket through which water was made to flow in the opposite direction to the flow of the air. His results substantially confirm Reynolds's law.

He found that in (1) above A is a constant for a clean metal surface and equal to 0.0015, and B is a function both of the dimensions of the channel and of the temperature, and is given by the equation

$$B = 0.000506 - 0.00045m + 0.00000165 \left(\frac{T + \theta}{2} \right)$$

where $m = \frac{\text{cross-sectional area of channel in square inches}}{\text{perimeter in inches}}$

According to Jordan, therefore, the complete law of heat transmission will be in B.Th.U. per square foot per second per degree difference of temperature

$$Q = 0.0015 + \left[0.000506 - 0.00045m + 0.00000165 \left(\frac{T + \theta}{2} \right) \right] \frac{w}{a} \dots (2)$$

In Jordan's research the maximum temperature of the air at inlet to the tube was 750° F.

Professor J. T. Nicolson, in 1909,² showed that as the result of experiments on a modified Cornish boiler, the rate of heat transmission depended

¹ *Proceedings Inst. Mech. Eng.*, Dec., 1909.

² *Trans. Jun. Inst. of Engineers*, Feb., 1909, and *Proceedings Inst. Mech. Engineers*, Oct., 1909.

not only upon the product of speed and density of the gases, but also to some extent on the average value of the gas and wall temperatures, the hydraulic mean depth of the tube or tubes through which the gases passed, and upon the nature of the metal surface in contact with the gas.

According to Nicolson

$$Q = \left[\frac{\phi}{200} + \frac{\sqrt{\phi}}{40} \left(1 + \frac{1}{m_1} \right) \rho_1 \mu_1 \right] (T - \theta) \dots (3)$$

or

$$Q = \left[\frac{\phi}{200} + \frac{\sqrt{\phi}}{40} \left(1 + \frac{1}{m_1} \right) \frac{w_1}{a_1} \right] (T - \theta) \dots (4)$$

where Q = B.Th.U. transmitted per hour per square foot of heating surface,

T = average temperature of gases flowing along the tube in ° F.,

θ = temperature of the metal wall of tube in ° F.,

φ = ½(T + θ) = mean film temperature in ° F.,

ρ₁ = density of gases in pounds per cubic foot,

μ₁ = speed of gases in feet per second,

w₁ = pounds of gas flowing per second,

a₁ = area of tube in square feet,

m₁ = hydraulic mean depth of the tube in inches,
 = $\frac{\text{area of tube in inches}}{\text{perimeter of tube in inches}}$

157. Estimation of the Temperature of the Gases on leaving the Boiler.¹—For roughly correct estimates Reynolds's Law may be written

$$H = c\rho\mu\Delta = c\frac{w}{a}\Delta$$

where ρ = density of the gases in pounds per cubic foot,

μ = speed of the gases in feet per second,

a = area of cross section of the flues through which the gases pass (square feet),

Δ = average difference between the gas and water temperatures in ° F.,

c = a supposed constant quantity.

Applying this formula for the heat transmitted per second through an elementary length dx of a tube (or tubes) of bore d₁, through which gas at temperature T is passing and around whose outside diameter d₂ water at constant temperature t is flowing, we have, using the notation of Arts. 154 and 156,

$$dH = c_1\rho_1\mu_1(T - \theta)\pi d_1 dx \dots (1)$$

$$= c_2\rho_2\mu_2(\theta - t)\pi d_2 dx \dots (2)$$

$$= -sw_1 dT \dots (3)$$

From (1) and (2)

$$\frac{T - \theta}{\theta - t} = \frac{c_2\rho_2\mu_2 d_2}{c_1\rho_1\mu_1 d_1} = r \dots (4)$$

$$\therefore T - \theta = \frac{r}{1 + r} (T - t) \dots (5)$$

¹ See Professor J. T. Nicolson's paper on "Boiler Economics and the Use of High Gas Speeds," *Trans. Inst. of Engineers and Shipbuilders in Scotland*, 1911.

From (1) and (3), substituting from (6) for $T - \theta$

$$c_1 \rho_1 \mu_1 \cdot \frac{r}{1+r} (T-t) \pi d_1 dx = -s w_1 dT$$

$$\therefore c_1 \rho_1 \mu_1 \cdot \frac{r}{1+r} \cdot \pi d_1 \int_0^l dx = -s w_1 \int_{T_1}^{T_2} \frac{dT}{T-t}$$

$$\left(\frac{c_1 \rho_1 \mu_1 \cdot \frac{r}{1+r} \cdot \pi d_1}{s w_1} \right) l = \log_e \frac{T_1 - t}{T_2 - t}$$

or, since $\rho_1 \mu_1 = \frac{w_1}{a_1}$

$$\frac{c_1 r}{(1+r)s} \cdot \frac{\pi d_1 l}{a_1} = \log_e \frac{T_1 - t}{T_2 - t}$$

which may be written

$$\frac{1}{\beta} \cdot \frac{S}{a} = \log_e \frac{T_1 - t}{T_2 - t}$$

or
$$\frac{S}{a} = \beta \log_e \frac{T_1 - t}{T_2 - t} \dots \dots \dots (6)$$

where S = area of heating surface in square feet,
 a = cross-sectional area of flue in square feet,
 T_1 = furnace temperature,
 T_2 = chimney temperature, *i.e.* temperature of gases leaving the heating surface,
 t = steam temperature.

Hence from (6)

$$T_2 = t \left(1 - e^{-\frac{S}{\beta a}} \right) + T_1 e^{-\frac{S}{\beta a}}$$

$$= A + B T_1 \dots \dots \dots (7)$$

from which it will be seen that, for a boiler of given "surface section ratio" $\left(\frac{S}{a}\right)$ the chimney temperature is a linear function of the furnace temperature, increasing and diminishing therewith.

158. The most Efficient Rate of Combustion.¹—In all boilers the two chief sources of loss are furnace loss and chimney loss. The chief source of loss in the furnace is the blowing out of the fire of coal dust and small coal, which is carried right through the flues without being burned and goes away up the chimney. At low rates only very fine dust escapes this way and the action is probably unimportant; but with the fierce blast of a locomotive running at full speed there is a constant rain of quite large pieces of coal from the top of the funnel, and by far the greatest proportion of all the loss incurred in the furnace is due to this cause.¹ Professor Nicolson finds that the combined loss of heat due to

¹ For the substance of this article the author is indebted to Professor Nicolson's paper on "Boiler Economics and the Use of High Gas Speeds," *Trans. Inst. of Engineers and Shipbuilders in Scotland*, 1911.

² See papers by F. J. Brislee and L. H. Fry in *Proc. Inst. Mech. Eng.*, 1908, pp. 237 and 269.

imperfect combustion and coal blown away amounts to 50F, B.Th.U. per pound of coal, and that the heat actually generated in the fire per pound of coal is

$$Q_0 = Q - 50F \quad \dots \dots \dots (1)$$

where Q = calorific value of the coal in B.Th.U. per pound,
 F = rate of firing in pounds of coal per square foot of grate per hour.

Chimney Loss.—The chimney loss per pound of coal is (Art. 144)

$$W \times s(t_1 - t_2) \text{ B.Th.U.}$$

where W = weight in pounds of the flue gases per pound of fuel burned,
 s = mean specific heat of the flue gases,
 t_1 = temperature ($^{\circ}$ F.) of the flue gases leaving the boiler,
 t_2 = temperature ($^{\circ}$ F.) of air in boiler house.

Furnace Temperature.—The heat generated in the fire per square foot of grate per hour is $Q_0 \times F$. This heat is disposed of in two ways—

- (1) By radiation from the fire surface to the furnace plates.
- (2) By heat communicated to the products of combustion, their temperature being thereby raised from t_2 to T_1 .

By Stefan and Boltzmann's law of radiation the quantity of heat radiated per hour per square foot of fire surface is

$$R = 1600 \left(\frac{\tau_0}{1000} \right)^4 \text{ B.Th.U.} \quad \dots \dots \dots (2)$$

where $\tau_0 = T_1 + 460$, the absolute temperature of the fire surface. The heat received by the furnace gases per square foot of grate per hour is

$$W \times s \times F(T_1 - t_2) \text{ B.Th.U.}$$

Therefore, the heat equation for one square foot of grate may be written

$$(Q - 50F)F = 1600 \left(\frac{\tau_0}{1000} \right)^4 + W \times s \times F(\tau_0 - t_0) \quad \dots (3)$$

where t_0 = absolute temperature of air supply = $t_2 + 460$.

From the study of many boiler trials it appears that the amount of air supplied per pound of coal with good firing is

$$A = \frac{300}{F} + 9 \text{ pounds per pound of coal}$$

Hence the weight of the flue gases per pound of coal is $A + 1$ or

$$W = \frac{300}{F} + 10 \quad \dots \dots \dots (4)$$

Substituting (4) in (3) the heat equation reduces to

$$\begin{aligned} \left(\frac{\tau_0}{1000} \right)^4 + (46.9 + 1563F) \left(\frac{\tau_0}{1000} \right) \\ = \frac{(Q - 50F)}{1600} F + 24.4 + 0.812 F \quad \dots \dots \dots (5) \end{aligned}$$

From (5) the absolute furnace temperature τ_0 , and therefore T_1 , may be calculated for various values of F . If this be done and a curve be plotted connecting T_1 and F , it will be seen that the furnace temperature,

T_1 , as thus determined, rises very rapidly at first as F increases, reaches a maximum for $F = 80$, and then begins to fall. One ought to expect an increase of the furnace temperature with an increased rate of combustion, because less air is supplied per pound of coal, and there is, consequently, a smaller weight of products to be heated up. Recalling, however, the fact that the heat actually generated in the fire per pound of coal gets less and less, owing to imperfect combustion and coal blown away, it will readily appear that this source of loss will presently overtake the gain due to diminished air supply, the furnace temperature curve will rise less and less steeply, and will finally attain a maximum and afterwards fall.

The chimney temperature t_1 may now be found for the various values of τ_0 (or T_1) by using equation (7), Art. 157, and hence the chimney loss. By adding the chimney loss to the furnace loss the whole loss of heat in the boiler due to these two causes together for various rates of firing may be found. If this be done it will be found that the most efficient rate of firing occurs at between 25 and 30 pounds of coal per hour per square foot of grate area. For smaller values, the combustion is more perfect, but the larger chimney loss, due to the larger amount of air supplied, more than makes up for this. For higher rates the chimney loss gets less, but imperfect combustion and coal blown away out of the fire does away with this advantage.

159. Heat Transmission through Condenser Tube.—In the usual arrangement of surface condenser the steam is condensed on the outside of a set of tubes through which the condensing water is circulating. The rate at which steam can be condensed in this way depends upon the temperature gradient through the tube walls and also upon the condition of the steam. The rate of condensation measured by Dr. Nicolson in a steam-engine cylinder was equal to 0.74 B.Th.U. per square foot of surface per second per degree difference of temperature between the steam and cylinder walls, but the conditions in an engine cylinder differ considerably from those in a surface condenser.

Experiment shows that the rate of condensation depends upon

- (1) The dryness fraction and pressure of the steam,
- (2) The velocity of the steam over the tubes,
- (3) The amount of air present in the steam,
- (4) The velocity of the condensing water through the tubes.

Considerable evidence exists to show that the rate of condensation appears to increase according to a nearly linear law with increasing speed of flow both of the steam and condensing water. Mr. Jordan¹ records a rate equal to 1.26 B.Th.U. per second per square foot per degree difference of temperature due to the high speed of the steam and condensing water; he also found that dry steam condensed more rapidly than wet steam, and further, that the rate of condensation was greater at 25 pounds per square inch absolute than at 40 pounds absolute. It should be pointed out, however, that the increased rate of heat transfer through the tubes, both for condenser and boiler tubes, due to speeds of flow greater than those commonly used in practice, would only be obtained at the expense of power for producing the circulation, and it must be a matter of experience to decide how far the rate of heat transmission may economically be increased.

¹ *Proc. Inst. Mech. Engineers*, 1909, p. 998.

At the usual condenser pressures and temperatures used in practice, the presence of small quantities of air causes a rapid falling off in the rate of condensation, which becomes less rapid as the quantity of air is increased. For the results of actual tests and data the reader is referred to the following important papers:—

“Efficiency of Surface Condensers,” R. L. Weighton, Inst. Naval Architects, April, 1906, and *Engineering*, April 13 and 20, 1906.

“Efficiency and Design of Surface Condensers,” T. E. Stanton, *Proc. Inst. C.E.*, vol. cxxxvi., Part 2, 1898–9.

“Surface Condensers for Steam Turbines,” *Engineering*, December 11, 1908.

“Air in Relation to the Surface Condensation of Low-Pressure Steam,” J. A. Smith, Victorian Inst. of Engineers, December, 1905, and *Engineering*, March 23, 1906, p. 395.

“Design of Surface Condensers,” R. M. Neilson, Inst. of Engineers and Shipbuilders in Scotland, 1910.

“Modern Condensing Systems,” A. E. Leigh Scanes, Inst. Mech. E., February 14, 1913.

EXAMPLES XII

1. In order to determine the amount of heat lost by radiation from a metal surface, a cast-iron bar of square section 4 inches \times 4 inches was heated at one end. When a steady condition was attained the temperatures were read from thermometers placed at different distances along the bar. Obtain a formula by means of which the amount of heat radiated per square foot per degree difference of temperature between the temperature of the bar and atmosphere can be calculated. Determine the actual amount of radiation from the figures given below:—

Distance from end in inches	0	6	12	21	30	41
Temperature ($^{\circ}$ F.)	235	171	131.5	97.9	80.5	69.2

Conductivity of cast iron, 5.4 B.Th.U. per square foot per minute per $^{\circ}$ F. per inch thick. Temperature of atmosphere, 59.5 $^{\circ}$ F.

2. The furnace tube of a Lancashire boiler is 36 inches diameter; coal burned on a grate 20 square feet in area, 400 pounds per hour; air supplied per pound of coal, 24 pounds. Temperature of the gases leaving the fire 2200 $^{\circ}$ F., temperature of the gases at the end of the tube 900 $^{\circ}$ F., steam temperature 350 $^{\circ}$ F. Estimate the number of B.Th.U. transmitted through the tube per square foot per hour (a) using Rankine's formula

$H = \left(\frac{t_1 - t_2}{200} \right)^2$, Art. 151; (b) using Jordan's formula (2), Art. 156; (c) using Nicolson's formula (4), Art. 156.

3. In a surface condenser with 6000 square feet of cooling surface it was found that 58,000 pounds of steam were condensed per hour. The average temperature of the steam was 132 $^{\circ}$ F., and of the circulating water 80 $^{\circ}$ F. The tubes were of brass 0.05 inch thick and of such a conductivity that 25 B.Th.U. could pass per minute through a plate 1 square foot in area 1 inch thick, per degree difference in temperature between the two surfaces. Calculate the temperatures of the metal on the steam and water sides of the tubes. Assume that when steam is in contact with a metal surface the rate of condensation is 0.74 (T - t) B.Th.U. per square foot per second, where T is the temperature of the steam and t the temperature of the metal, and latent heat at 132 $^{\circ}$ F. = 1020 B.Th.U. per pound.

CHAPTER XIII

THEORY OF THE GAS ENGINE

160. Internal Combustion Engines. General Considerations.—The term “internal combustion engine” includes all types of gas, oil, and petrol engines; in this chapter the theory of the gas engine alone is considered, on the assumption that the specific heat of the gases remains *constant*, the variable specific heat theory being investigated in Chapter XIV. It will be as well to briefly compare the internal combustion engine with the steam engine, as by that means it will be easy to understand why its thermodynamic efficiency is so much greater than that of the steam engine.

In the steam engine the heat generated by the combustion of the fuel in the furnace passes through the metal plates or tubes of the boiler to the water, and so generates steam which is used in the engine cylinder to do work; the working fluid is therefore entirely different from the products of combustion of the fuel. In the steam engine there are four different organs, namely: the furnace, boiler, engine cylinder, and condenser (if the engine is condensing). In the gas engine, however, there are only two organs, the gas producer and the engine cylinder, into which a mixture of gas, or oil vapour, and air in suitable proportions is admitted and exploded when the piston is beginning to move forward on its working stroke. Heat is developed as the result of the explosion, the gases expand, driving the piston forward and so doing useful work; on the return of the piston the products of combustion are driven out of the cylinder and the operation is then repeated. An oil engine is essentially a special form of gas engine with a *vaporiser* or *carburettor* attached, wherein the oil is converted into a gas or vapour and then used in the cylinder in the same way as the gas in a gas engine.

The maximum temperature reached in the engine cylinder is very high, so that the range of temperature T_1 to T_2 is large. The full thermodynamic advantages of this high initial temperature cannot be realised in practice, since, if the cylinder walls are allowed to reach this high temperature, they would soon be destroyed and lubrication of the piston would be impossible, to say nothing of the risk of premature ignition of the incoming mixture of gas and air; hence, the cylinder is water-jacketed to keep it cool. With large gas engines the difficulty is to keep the cylinder, piston and valves cool enough; with steam engines, on the other hand, the cylinder should be kept hot to reduce the losses due to condensation of the steam. There are a great and increasing number of gas and oil engines on the market, for a detailed description of which the reader is referred to the Technical Press and to standard books on the subject.¹

¹ See Robinson's "Gas and Petroleum Engines"; "The Internal Combustion Engine," H. E. Wimperis; or D. Clark's "Gas, Oil and Petrol Engines" (Longmans).

Internal combustion engines may be divided into three classes, namely—

1. Engines in which the explosion takes place at *constant volume without any previous compression*. No modern engine works on this principle.
2. Engines in which the explosion takes place at *constant volume with previous compression*.
3. Engines in which the combustion takes place at *constant pressure with previous compression*.

In the discussion which follows, ideal indicator diagrams and conditions are assumed which cannot be obtained in practice. Further, to obtain the greatest possible efficiency, it is assumed—

1. That the explosion is instantaneous and takes place at constant volume in the first two of the above classes, the specific heats C_p and C_v remaining constant at all temperatures.

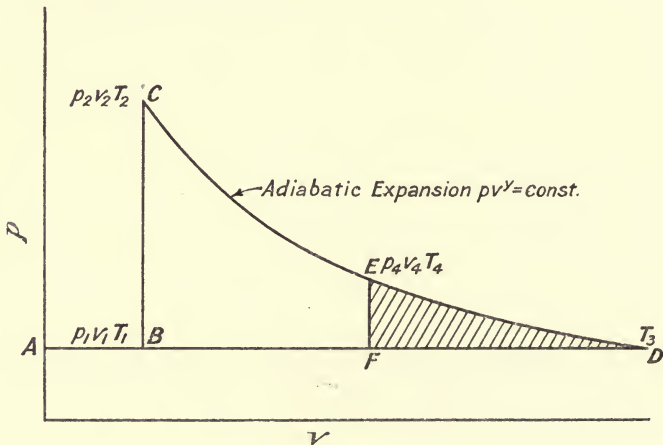

FIG. 123.

2. That the expansion (and compression in those engines which use compression) is adiabatic, which necessitates the assumption that the cylinder walls and piston are perfect non-conductors of heat.

3. That the products of combustion expand right down to atmospheric pressure and are exhausted at that pressure.

4. That the explosive mixture of gas and air is admitted during the suction stroke at atmospheric pressure.

161. Engines in which the Explosion takes place at Constant Volume without Previous Compression.—The ideal indicator diagram for this cycle is shown in Fig. 123. The mixture of gas and air is drawn in at atmospheric pressure along AB, then follows explosion at constant volume from B to C, followed by adiabatic expansion CD down to atmospheric pressure and exhaust DA at the same pressure.

Let T_1 = initial absolute temperature of the charge at A or B,

T_2 = maximum temperature reached at C,

T_3 = temperature at D after expansion.

Then we have per pound of the gaseous mixture,

$$\text{Heat supplied by the explosion} = H_1 = C_v(T_2 - T_1) \dots (1)$$

$$\text{Heat rejected} = H_2 = C_p(T_3 - T_1) \dots (2)$$

$$\begin{aligned} \text{Efficiency} &= \frac{H_1 - H_2}{H_1} \\ &= \frac{C_v(T_2 - T_1) - C_p(T_3 - T_1)}{C_v(T_2 - T_1)} = 1 - \gamma \cdot \frac{T_3 - T_1}{T_2 - T_1} \dots (3) \end{aligned}$$

No modern engine works on this cycle; the Lenoir and Hugon engines were representatives of this type, the ideal indicator diagram being represented by BCEF (Fig. 123). It will be noticed that there was a loss of work due to incomplete expansion represented in amount by the shaded area FED. The efficiency of this ideal Lenoir cycle may be obtained as follows:—

Let the conditions be at B $p_1 v_1 T_1$, at C $p_2 v_2 T_2$, at E $p_4 v_4 T_4$, then we have—

$$\begin{aligned} \text{Work done during adiabatic expansion from C to E} \\ &= \frac{p_2 v_2 - p_4 v_4}{\gamma - 1} \end{aligned}$$

and since $p v = R T$, this may be written

$$\frac{R}{\gamma - 1} (T_2 - T_4) = C_v (T_2 - T_4) \dots (4)$$

$$\begin{aligned} \text{Work done in driving out exhaust gases from F to B} \\ &= p_1 (v_4 - v_2) \dots (5) \end{aligned}$$

$$\begin{aligned} \text{Net amount of work done during the cycle} &= (4) - (5) \\ &= C_v (T_2 - T_4) - p_1 (v_4 - v_2) \dots (6) \end{aligned}$$

$$\begin{aligned} \text{Heat supplied from B to C} &= C_v (T_2 - T_1) \\ \text{Hence efficiency} &= \frac{C_v (T_2 - T_4) - p_1 (v_4 - v_2)}{C_v (T_2 - T_1)} \end{aligned}$$

$$\begin{aligned} &= \frac{T_2 - T_4}{T_2 - T_1} - \frac{p_1 (v_4 - v_2)}{C_v (T_2 - T_1)} \\ &= \frac{T_2 - T_4}{T_2 - T_1} - p_1 \cdot \frac{\gamma - 1}{R} \cdot \frac{v_4 - v_2}{T_2 - T_1} \dots (7) \end{aligned}$$

162. Atmospheric Engine.—The Otto and Langen engine worked on a modification of this cycle. Like the Lenoir engine this cycle is obsolete, but it will be instructive to briefly consider the cycle and to determine its ideal thermal efficiency.

The mixture of gas and air is drawn in at atmospheric pressure along AB (Fig. 124), then follows explosion at constant volume from B to C and adiabatic expansion along CD, followed by isothermal compression DB and exhaust BA at atmospheric pressure.

Let the conditions be at B $p_1 v_1 T_1$, at C $p_2 v_2 T_2$, at D $p_3 v_3 T_3$, then we have—

$$\begin{aligned} \text{Work done on the piston during adiabatic expansion CD} \\ &= \frac{p_2 v_2 - p_3 v_3}{\gamma - 1} \dots (1) \end{aligned}$$

Work done by the piston on the gas during isothermal compression DB

$$= p_1 v_1 \log_{\epsilon} \frac{v_3}{v_1} \dots \dots \dots (2)$$

Net amount of work done during the cycle

$$\begin{aligned} &= \frac{p_2 v_1 - p_3 v_3}{\gamma - 1} - p_1 v_1 \log_{\epsilon} \frac{v_3}{v_1} \\ &= \frac{p_2 v_1 - p_3 v_3}{\gamma - 1} - p_1 v_1 \log_{\epsilon} \frac{v_3}{v_1} \end{aligned}$$

and efficiency

$$\begin{aligned} &= \frac{p_2 v_1 - p_3 v_3}{\gamma - 1} \dots \dots \dots (3) \\ &= 1 - \frac{(\gamma - 1) p_1 v_1 \log_{\epsilon} \frac{v_3}{v_1}}{p_2 v_1 - p_3 v_3} \dots \dots \dots (4) \end{aligned}$$

But $p_1 v_1 = p_3 v_3$ since DB is an isothermal, $\therefore \frac{v_3}{v_1} = \frac{p_1}{p_3}$, and $\left(\frac{v_3}{v_1}\right)^{\gamma-1} = \frac{T_2}{T_3}$ by (4), Art. 11.

$$\therefore \frac{v_3}{v_1} = \left(\frac{T_2}{T_3}\right)^{\frac{1}{\gamma-1}} = \left(\frac{T_2}{T_1}\right)^{\frac{1}{\gamma-1}} \text{ since } T_3 = T_1$$

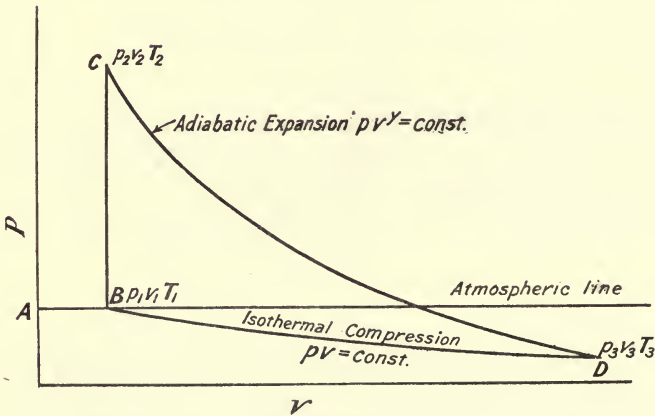

FIG. 124.

Substituting in (4) we get

$$\begin{aligned} \text{efficiency} &= 1 - \frac{(\gamma - 1) p_1 v_1 \log_{\epsilon} \left(\frac{T_2}{T_1}\right)^{\frac{1}{\gamma-1}}}{v_1 (p_2 - p_1)} \\ &= 1 - \frac{(\gamma - 1) \cdot p_1 \cdot \log_{\epsilon} \left(\frac{T_2}{T_1}\right)^{\frac{1}{\gamma-1}}}{p_2 - p_1} \dots \dots \dots (5) \end{aligned}$$

$$= 1 - \frac{(\gamma - 1) T_1 \cdot \log_{\epsilon} \left(\frac{T_2}{T_1}\right)^{\frac{1}{\gamma-1}}}{T_2 - T_1} \dots \dots \dots (6)$$

163. Engine in which the Explosion takes place at Constant Volume with Previous Compression.—The ideal cycle for this type of engine is shown in Fig. 125. The mixture of gas and air is drawn in at atmospheric pressure along the suction stroke AB and compressed adiabatically along BC during the return of the piston; then follows explosion at constant volume from C to D and adiabatic expansion right down to atmospheric pressure at E, followed by exhaust at that pressure along EA.

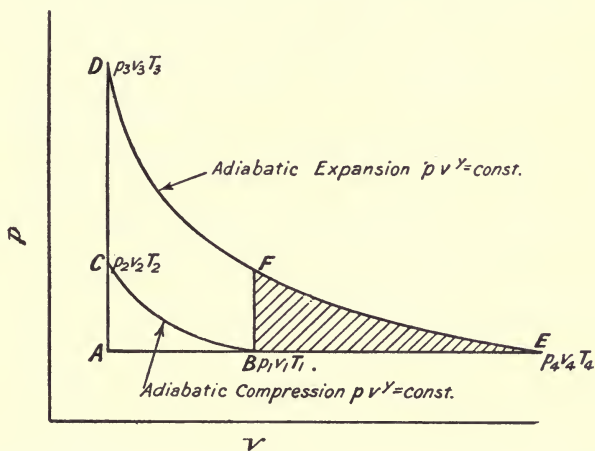

FIG. 125.

Let the conditions be at B $p_1 v_1 T_1$, at C $p_2 v_2 T_2$, at D $p_3 v_3 T_3$, at E $p_4 v_4 T_4$, then per pound of working fluid we have—

$$\text{Heat supplied at constant volume from C to D} = C_v(T_3 - T_2) \quad (1)$$

$$\text{Heat rejected at atmospheric pressure from E to A} = C_p(T_4 - T_1) \quad (2)$$

$$\text{Net amount of heat converted into work} = C_v(T_3 - T_2) - C_p(T_4 - T_1)$$

$$\begin{aligned} \text{efficiency} &= \frac{C_v(T_3 - T_2) - C_p(T_4 - T_1)}{C_v(T_3 - T_2)} \\ &= 1 - \gamma \cdot \frac{T_4 - T_1}{T_3 - T_2} \quad \dots \quad (3) \end{aligned}$$

In practice, however, this cycle is not realised. For mechanical reasons it is usual to work with a ratio of expansion equal to the ratio of compression, the expansion being stopped at point F. This results in incomplete expansion, the diagram being represented by BCDF, and the shaded area BFE represents the loss due to incomplete expansion. Compound gas engines have been proposed and constructed whereby this further expansion from F to E is carried out in a separate low-pressure cylinder; but almost all modern engines work on the cycle represented by BCDF. This cycle is known as the Otto, or four-stroke constant volume cycle, and is discussed further in Art. 166.

Efficiency of the Otto Cycle.—The ideal indicator diagram of this constant volume cycle is shown separately in Fig. 126 and the $T\phi$ diagram

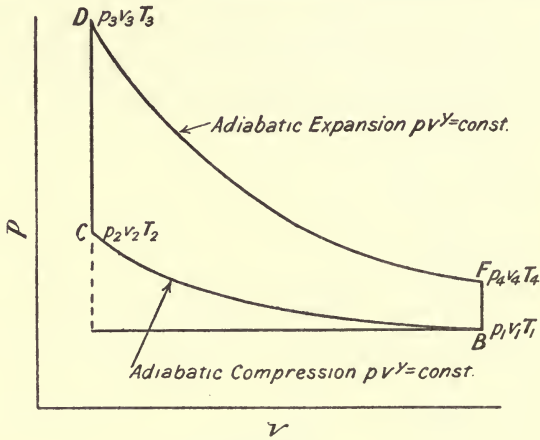

FIG. 126.

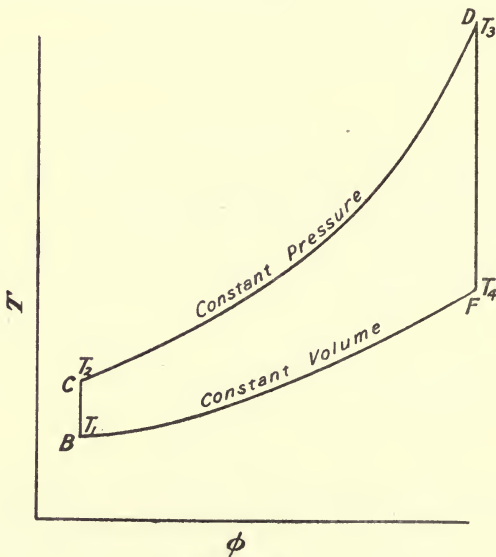

FIG. 126A.

in Fig. 126A. Let the conditions be at B $p_1 v_1 T_1$, at C $p_2 v_2 T_2$, at D $p_3 v_3 T_3$, at F $p_4 v_4 T_4$, then per pound of working fluid we have—

$$\text{Heat supplied at constant volume from C to D} = C_v(T_3 - T_2) \quad (4)$$

$$\text{Heat rejected at constant volume from F to B} = C_v(T_4 - T_1) \quad (5)$$

$$\begin{aligned} \text{Heat converted into work} &= \text{heat received} - \text{heat rejected} \\ &= C_v(T_3 - T_2) - C_v(T_4 - T_1) \end{aligned}$$

$$\begin{aligned} \text{Efficiency} &= \frac{C_v(T_3 - T_2) - C_v(T_4 - T_1)}{C_v(T_3 - T_2)} \\ &= 1 - \frac{T_4 - T_1}{T_3 - T_2} \dots \dots \dots (6) \end{aligned}$$

Now, since the ratios of adiabatic expansion and compression are equal,

$$\frac{T_4}{T_3} = \frac{T_1}{T_2} \text{ or } \frac{T_4}{T_3} = \frac{T_1}{T_2} = \frac{T_4 - T_1}{T_3 - T_2} \dots \dots \dots (7)$$

Substituting (7) in (6)

$$\text{Efficiency} = 1 - \frac{T_4}{T_3} \text{ or } 1 - \frac{T_1}{T_2} \dots \dots \dots (8)$$

Again
$$\frac{T_4}{T_3} = \frac{T_1}{T_2} = \left(\frac{v_2}{v_1}\right)^{\gamma-1} = \left(\frac{1}{r}\right)^{\gamma-1} \text{ by (4), Art. 11}$$

where $\frac{v_1}{v_2} = r$, the ratio of expansion or compression. Hence the efficiency may be written

$$1 - \left(\frac{1}{r}\right)^{\gamma-1} \dots \dots \dots (9)$$

This efficiency is frequently called the Air Standard Cycle Efficiency where γ is taken as 1.4, the value of $\frac{C_p}{C_v}$ for air. Equation (9) also shows that, on the assumption that the specific heat of the working fluid remains constant, increasing the ratio of compression and therefore increasing the pressure, *i.e.* the pressure at the end of the compression stroke, results in a higher efficiency.

The actual value of γ for the mixture in an internal combustion engine varies from 1.36 to 1.38. Within these limits the exact value taken for γ does not materially affect the efficiency of the ideal engine, as will be evident from the following tabulated values :—

EFFICIENCIES OF AIR STANDARD CYCLE $1 - \left(\frac{1}{r}\right)^{\gamma-1}$

r	$\gamma = 1.40$	$\gamma = 1.37$	$\gamma = 1.3$
3	0.36	0.332	0.28
4	0.43	0.399	0.34
5	0.47	0.45	0.38
6	0.52	0.49	0.42
7	0.55	0.51	0.44
10	0.61	0.57	0.50

The temperature-entropy diagram of this cycle is shown in Fig. 126A.

164. The Atkinson Cycle.—The Atkinson cycle is a modification of the Otto cycle, and was an attempt to approach nearer to the ideal cycle shown by BCDE in Fig. 125. In this cycle the working fluid was allowed to expand adiabatically to *double* its volume before compression, so that the ratio of adiabatic expansion was *twice* the ratio of adiabatic compression. By this means the loss due to incomplete expansion was reduced although the pressure at the end of expansion was still considerably above atmospheric.

The ideal diagram for this cycle is shown in Fig. 127. The mixture of gas and air was drawn in at atmospheric pressure along AB, then followed adiabatic compression BC, explosion at constant volume from C to D; adiabatic expansion DE, the volume at E being twice that at B, and exhaust at atmospheric pressure from F to A.

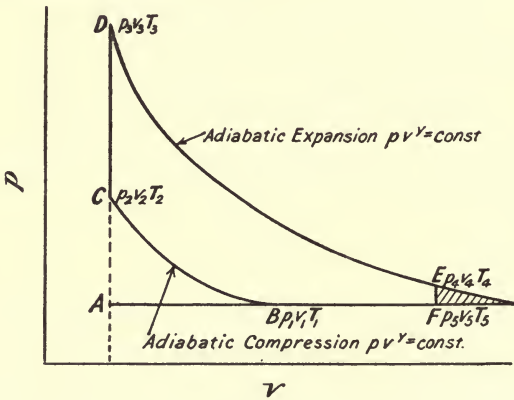

FIG. 127.

Let the conditions be at B $p_1 v_1 T_1$, at C $p_2 v_2 T_2$, at D $p_3 v_3 T_3$, at E $p_4 v_4 T_4$, at F $p_5 v_5 T_5$, then per pound of working fluid we have—

$$\text{Heat supplied at constant volume from C to D} = C_v(T_3 - T_2) \quad (1)$$

$$\text{Heat rejected at constant volume from E to F} = C_v(T_4 - T_5)$$

$$\text{Heat rejected at constant pressure from F to B} = C_p(T_5 - T_1)$$

$$\text{Total heat rejected} = C_v(T_4 - T_5) + C_p(T_5 - T_1) \quad \dots \quad (2)$$

$$\text{Heat converted into work} = \text{heat supplied} - \text{heat rejected}$$

$$= C_v(T_3 - T_2) - C_v(T_4 - T_5) - C_p(T_5 - T_1)$$

$$\text{Efficiency} = \frac{C_v(T_3 - T_2) - C_v(T_4 - T_5) - C_p(T_5 - T_1)}{C_v(T_3 - T_2)}$$

$$= 1 - \frac{T_4 - T_5 + \gamma(T_5 - T_1)}{T_3 - T_2} \quad \dots \quad (3)$$

It is obvious that this ideal efficiency is greater than that of the Otto cycle, because, for the same quantity of heat supplied during the explosion at constant volume there is more work done on account of the increased expansion.

165. Engine in which the Combustion takes place at Constant Pressure with Previous Compression.—The ideal $p v$ diagram for this cycle is shown in Fig. 128, and the $T \phi$ diagram in Fig. 128A. The mixture of gas and air is drawn in at atmospheric pressure during the suction stroke AB, and on the return of the piston is compressed adiabatically from B to C. Combustion then takes place at constant pressure along CD, followed by adiabatic expansion from D to E, the gases being finally exhausted at atmospheric pressure from E to A.

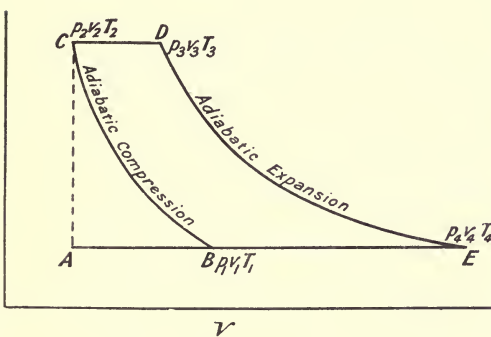

FIG. 128.

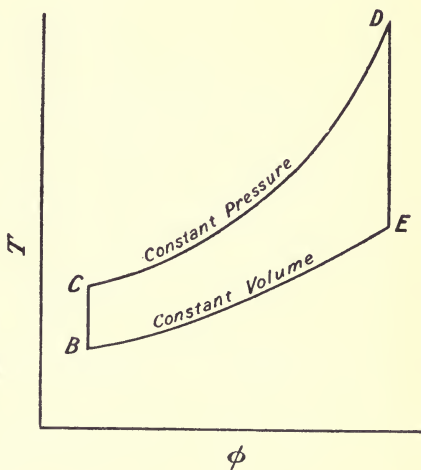

FIG. 128A.

Let the conditions be, at B $p_1 v_1 T_1$, at C $p_2 v_2 T_2$, at D $p_3 v_3 T_3$, at E $p_4 v_4 T_4$, then per pound of the working fluid we have—

$$\text{Heat supplied at constant pressure from C to D} = C_p(T_3 - T_2) \quad (1)$$

$$\text{Heat rejected at constant pressure from E to B} = C_p(T_4 - T_1) \quad (2)$$

$$\text{Heat converted into work} = C_p(T_3 - T_2) - C_p(T_4 - T_1)$$

$$\begin{aligned} \text{Efficiency} &= \frac{C_p(T_3 - T_2) - C_p(T_4 - T_1)}{C_p(T_3 - T_2)} \\ &= 1 - \frac{T_4 - T_1}{T_3 - T_2} \dots \dots \dots (3) \end{aligned}$$

Also, since the expansion and compression are adiabatic,

$$\frac{T_4}{T_3} = \frac{T_1}{T_2}$$

hence

$$\frac{T_4}{T_3} = \frac{T_1}{T_2} = \frac{T_4 - T_1}{T_3 - T_2}$$

Hence (3) may be written

$$\text{Efficiency} = 1 - \frac{T_4}{T_3} \text{ or } 1 - \frac{T_1}{T_2} \dots \dots \dots (4)$$

But
$$\frac{T_4}{T_3} = \frac{T_1}{T_2} = \left(\frac{v_2}{v_1}\right)^{\gamma-1} = \left(\frac{p_1}{p_2}\right)^{\frac{\gamma-1}{\gamma}}$$

and (4) becomes

$$\begin{aligned} \text{Efficiency} &= 1 - \left(\frac{v_2}{v_1}\right)^{\gamma-1} \quad \text{or} \quad 1 - \left(\frac{p_1}{p_2}\right)^{\frac{\gamma-1}{\gamma}} \\ &= 1 - \left(\frac{1}{r}\right)^{\gamma-1} \quad \dots \dots \dots (5) \end{aligned}$$

where r is the ratio of compression,

No gas engine works on this cycle, but the Diesel oil engine approximates to it (see Art. 192).

EXAMPLE 1.—In an ideal Lenoir engine the temperature of the incoming charge is 60° F. at 15 lbs. per square inch absolute, and the maximum temperature of explosion is 2800° F. If the ratio of expansion is 2 and the initial volume one cubic foot, estimate the efficiency. (Take $\gamma = 1.38$.)

$$\begin{aligned} \text{Here } T_1 &= 60 + 460 = 520^\circ \\ T_2 &= 2800 + 460 = 3260^\circ \end{aligned}$$

To find T_4 , the temperature after adiabatic expansion,

now
$$\frac{T_4}{T_2} = \left(\frac{v_2}{v_4}\right)^{\gamma-1} = \left(\frac{1}{r}\right)^{0.38}$$

$\therefore T_4 = 3260 \times \left(\frac{1}{2}\right)^{0.38} = 2505^\circ$ absolute.

Now
$$R = \frac{p_1 v_1}{T_1} = \frac{15 \times 144 \times 1}{520}$$

Using equation (7), Art. 161, we have—

$$\begin{aligned} \text{efficiency} &= \frac{T_2 - T_4 - p_1 \cdot \frac{\gamma-1}{R} (v_4 - v_2)}{T_2 - T_1} \\ \text{Substituting} \quad \text{efficiency} &= \frac{(3260 - 2505) - 15 \times \frac{0.38 \times 520}{15 \times 144} \times 1}{3260 - 520} \\ &= \frac{756 - 1.37}{2740} = 0.275 \text{ or } 27.5 \text{ per cent.} \end{aligned}$$

N.B.—Note that the Carnot efficiency would be

$$\frac{3260 - 520}{3260} = \frac{2740}{3260} = 0.840 \text{ or } 84 \text{ per cent.}$$

EXAMPLE 2.—In an ideal Otto and Langen engine the initial and explosion temperatures are the same as in Example 1. Assuming $\gamma = 1.38$, estimate its efficiency.

By equation (6), Art. 162,

$$\text{Efficiency} = 1 - \frac{(\gamma - 1)T_1 \log_{\epsilon} \left(\frac{T_2}{T_1} \right)^{\frac{1}{\gamma-1}}}{T_2 - T_1}$$

Now $T_2 = 3260$
and $T_1 = 520$

$$\therefore \text{efficiency} = 1 - \frac{0.38 \times 520 \times \log_{\epsilon} \left(\frac{3260}{520} \right)^{\frac{1}{0.38}}}{3260 - 520}$$

$$= 1 - \frac{0.38 \times 520 \times 2.303 \log_{10} \left(\frac{3260}{520} \right)^{2.63}}{2740}$$

$$\therefore \text{efficiency} = 1 - \frac{0.38 \times 520 \times 2.303 \times 2.0948}{2740} = 1 - 0.348 = 0.652$$

EXAMPLE 3.—In an engine working on the Otto cycle the following temperatures were measured: Temperature of suction = 210° F., at end of compression 590° F., maximum temperature of explosion 2093° F., at end of expansion 1594° F. Estimate the ratio of compression and the ideal efficiency. Assume the law of compression to be $p v^{1.445} = \text{const.}$ (The above data is taken from the A7 trial given in the second report of the Gas Engine Research Committee, published in the *Proceedings* of the Institution of Mechanical Engineers, October–December, 1901.)

Let $T_1 =$ temperature of compression = $590 + 460 = 1050$,
 $T_2 =$ „ suction = $210 + 460 = 670$,

Then $\frac{T_1}{T_2} = \left(\frac{v_2}{v_1} \right)^{\gamma-1} = r^{0.445}$

$$\therefore 0.445 \log r = \log T_1 - \log T_2 = 3.0216 - 2.8267 = 0.1949$$

$$\therefore \log r = \frac{0.1949}{0.445} = 0.4379 = \log 2.741$$

$$\therefore \text{ratio of expansion and compression} = 2.741$$

$$\text{efficiency} = 1 - \left(\frac{1}{r} \right)^{\gamma-1}$$

$$= 1 - \left(\frac{1}{2.741} \right)^{0.445}$$

$$= 1 - 0.638 = 0.362 \text{ or } 36.2 \text{ per cent.}$$

This result may be checked by the shorter method, Art. 163, equation 8.

$$\text{Efficiency} = 1 - \frac{T_1}{T_2}$$

$$= 1 - \frac{670}{1050} = 1 - 0.638 = 0.362 \text{ as before}$$

EXAMPLE 4.—Suppose the above engine worked on the Atkinson cycle with the same maximum and suction temperatures: estimate its efficiency, assuming the temperature of exhaust to be 400° F.

We must first find T_4 , the temperature after expansion.

$$\frac{T_3}{T_4} = r^{0.445}, \text{ where } T_3 = \text{maximum temperature of explosion.}$$

Now $r = 2 \times 2.741 = 5.482$

$$\therefore T_4 = \frac{T_3}{r^{0.445}} = \frac{2093 + 460}{5.482^{0.445}} = \frac{2553}{5.482^{0.445}}$$

$$\log T_4 = \log 2553 - 0.445 \log 5.482$$

$$= 3.4072 - 0.445 \times 0.7390 = 3.4072 - 0.3288 = 3.0784$$

$$\therefore T_4 = 1198^\circ \text{ absolute} = 738^\circ \text{ F.}$$

Hence efficiency = $1 - \frac{(T_4 - T_5) + \gamma(T_5 - T_1)}{T_3 - T_2}$ (Art. 164, equation 3)

Substituting we get

$$\begin{aligned} \text{Efficiency} &= 1 - \frac{(1198 - 860) + 1.445(860 - 670)}{2553 - 1050} \\ &= 1 - \frac{337 + 1.445 \times 190}{1503} = 1 - \frac{337 + 274.55}{1503} \\ &= 1 - \frac{611.55}{1503} = 1 - 0.406 = 0.594 \text{ or } 59.4 \text{ per cent.} \end{aligned}$$

166. **Otto Cycle.**—Dr. Otto first made a gas engine to work on the cycle patented by Beau de Rochae, and many modern engines work on this, or at any rate a modification of this, cycle, which may be represented thus—

Direction of stroke.	Name of stroke.
One revolution $\left\{ \begin{array}{l} \rightarrow \\ \leftarrow \end{array} \right.$	charging compression
One revolution $\left\{ \begin{array}{l} \rightarrow \\ \leftarrow \end{array} \right.$	explosion and expansion exhaust

The charge of gas and air is first drawn into the cylinder on the outward stroke of the piston, and on the return stroke is compressed, ignition takes place just when the piston is moving on its next outward stroke, and on the return stroke the products of combustion are driven out of the cylinder and the cycle is repeated. The indicator diagram is shown diagrammatically in Fig. 129. It will be noticed that during the charging stroke the pressure is below atmospheric (this is exaggerated in the diagram for clearness), and during exhaust is above atmospheric. The area of this loop of the diagram represents the work done on the gases during the cycle.

It will be seen that a working stroke takes place every *two* revolutions, or every *four* strokes when the engine is on full load and missing no explosions, hence the cycle is frequently spoken of as the four-stroke cycle. At the end of each exhaust stroke there remains in the clearance space

a volume of approximately one-third of the piston displacement filled with products of combustion largely composed of CO_2 and N_2 , which are both inert and non-combustible gases. The next charge of gas and air mixes with these inert gases, and, as a result, the explosion will not be so effective as it might be. It is for this reason that in many modern engines some arrangement is adopted to remove these products of combustion before the next charge is admitted into the cylinder. (See Art. 169.)

167. After Burning.—

In discussing the ideal conditions, one assumption made (Art. 160) was that the explosion was instantaneous and at constant volume. Actually it is found that the maximum pressure and temperature reached at the end of the explosion are much less than they would be if the explosion were instantaneous. According to Mr. Dugald Clerk¹ only about 65 per cent. of the potential heat of combustion is required to produce the maximum temperature reached, the remaining 35 per cent. of the heat being evolved by slow combustion during the expansion. This phenomenon is known as "after burning," and it is quite possible that in many cases the products which are discharged into the exhaust contain some incompletely burnt fuel. To explain this phenomenon of after burning, it has been suggested that the extremely high temperature reached in the first stage of the explosion prevents the chemical union which takes place during combustion from being completed, just as in the same way the products of combustion would be dissociated or split up into their constituent elements, until the fall of temperature by expansion and the cooling by the cylinder walls allows the process of union to continue. Against this theory is the fact that "after burning" is more pronounced with weak mixtures when the maximum temperature reached is much lower.

168. Effect of the Strength of the Mixture.—The minimum theoretical quantity of air required for complete combustion of one cubic foot of average coal gas is about 5 cubic feet (see Art. 143), but more than this is always supplied. The limits in practice seem to vary from about 6 to 14 cubic feet of air per cubic foot of gas, the average being from about 8 to 10 cubic feet at full load. Professor Burstall obtained the most economical result with from 9.48 to 10.8 cubic feet.² Dr. Otto laid great stress upon the desirability of having a stratified mixture of gases in the cylinder with a portion rich in gas near the place of ignition, but Mr. Clerk's experiments are conclusive against this. The only case in which this might be an advantage would be when dealing with a very weak

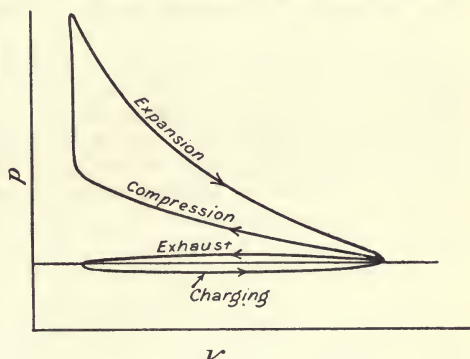

FIG. 129.

¹ See *Proceedings* of I. C. E., 1882 and 1886.

² See the "First Report of Gas Engine Research Committee" in *Proc. Inst. of Mech. Engineers*, April, 1898.

mixture, when a small quantity rich in fuel near the ignition point would tend to start combustion of the rest.

Professor Burstall also found that, within limits, weaker mixtures give higher efficiency than stronger ones. Professor Hopkinson¹ also found the same result from a series of experiments in which the proportion of air to gas was varied from 9·5 to 1 (the weakest mixture) to 7·5 to 1 (the strongest mixture). Within that range he found that the efficiency decreased steadily as the strength of mixture increased, the efficiency with the weakest mixture being 4·5 per cent. greater than that obtained with the strongest mixture. He also found that when using a mixture containing 8·5 per cent. of coal gas, the actual thermal efficiency was 0·87 of the ideal efficiency, but when the proportion of coal gas was increased to 11 per cent., the actual was reduced to 0·83 of the ideal efficiency; the weaker mixture, in addition to giving a higher ideal efficiency, came nearer in practice to realising that ideal. This may be due to the fact that the percentage of heat lost to the cylinder walls during expansion is less with weak mixtures than with stronger ones, the difference being sufficient to counterbalance the reverse effect of the more rapid combustion of the stronger mixtures.

Causes of Higher Efficiency with Weaker Mixtures.—That the efficiency will be higher with weaker mixtures may be deduced from the fact that the specific heat of the working gases increases with the temperature. The work done in the gas-engine cycle is mainly determined by the rise of pressure which occurs on explosion; and in the same engine the area of the indicator diagram with different mixtures is nearly proportional to this rise. If the specific heat of the working substance were constant, the rise of temperature and pressure due to the explosion would be proportional to the heat supply, and the efficiency would, therefore, be constant. Since, however, the specific heat is greater at high temperatures, the rise of temperature and pressure on explosion increases in a less ratio than the heat supply, and the efficiency therefore diminishes as the supply of heat is increased. This theory, however, does not explain why the weaker mixtures, in addition to giving a higher ideal efficiency, come nearer in practice to realising that ideal.

When the mean effective pressure in an engine cylinder is increased by using a stronger mixture, the effect of the increased temperature of combustion is to greatly increase the amount of heat radiated from the flame to the cylinder walls, since the heat radiated is proportional to the fourth power of the absolute temperature (Art. 185). The jacket loss and the metal temperature are thereby increased in a much greater proportion than the fuel consumption, and the efficiency is therefore diminished.

It is possible that with a strong mixture the percentage of gas present in all parts of the cylinder is not the same, and that some of the gas has not got next to it the requisite amount of oxygen for combustion, the result being that some of the gas is not burned. On the other hand, with a weaker mixture there is the great probability that all the molecules of gas are surrounded with sufficient oxygen to ensure combustion. If this assumption is justifiable, it offers another explanation why weak mixtures are more economical than strong ones; Professor Hopkinson found, however, that the percentage of unburnt gas in the exhaust did not depend

¹ "Effect of Mixture, Strength, and Scavenging upon Thermal Efficiency," *Proc. Inst. Mech. Engineers*, April, 1908.

upon the strength of the mixture, and that, moreover, he considered it very improbable that more than 1 per cent. of the fuel is ever unburnt at the end of the expansion stroke.

In large gas engines the use of strong mixtures is prohibited by the shock of the explosion, such engines always using producer gas or blast-furnace gas of very much lower heating value than coal gas; it is an advantage therefore that these weaker mixtures result in higher efficiency. In order that these weak mixtures may be explosive it is necessary to have a high compression of the charge before ignition. Theoretically, the higher the compression, the higher will be the efficiency ((9) Art. 163), but, according to Professor Burstall, there is a limit with the coal gas he used, about 175 pounds per square inch, beyond which increased compression does *not* result in increased efficiency.¹ The advantages of high over low compression before ignition may be briefly summed up as follows:—

1. The same weight of gas is compressed into a smaller volume and is therefore exposed to less cooling surface.

2. When ignition takes place the rate of combustion is more rapid under the higher pressure, so that the time of exposure to the smaller cooling surface is less than for slow combustion.

3. The maximum pressure and temperature is reached more quickly and the fall of pressure is more rapid than with the slower combustion of a low-pressure charge.

4. By high compression a weak diluted mixture is made combustible which will not burn at low pressure and temperature.

5. The power and efficiency are largely increased by high compression up to a certain limit of maximum pressure (about 600 pounds per square inch).

169. Scavenging.—To get rid of the burnt products of combustion mentioned in Art. 168 various methods have been tried. The obsolete Griffin, Linford, and Beck engines worked on a six-stroke cycle as follows:—

One revolution	{	→	Charging
		←	Compression
One revolution	{	→	Explosion and expansion
		←	Exhaust
One revolution	{	→	Air suction
		←	Air exhaust and scavenging

It will be seen that this cycle is the Otto cycle with two extra strokes added in which air only is drawn in during the suction stroke and on the return stroke is exhausted, driving out the burnt products of combustion of the previous explosion. The great drawback to this cycle is that there is only one working stroke every *three* revolutions when the engine is on full load and missing no explosions, which results in a large engine for a given power, and an irregular turning moment on the crankshaft necessitating the use of a very heavy flywheel effect if steady running is to be obtained. A great advantage is that the cylinder is well cooled.

If an indicator diagram be taken of the charging and exhaust strokes

¹ "Third Report of Gas Engine Research Committee," *Proc. Inst. Mech. Eng.*, 1908.

with a light spring it will frequently be found that the exhaust shows as a wavy line, the pressure falling at some point such as A (Fig. 130) below atmospheric. Mr. Atkinson took advantage of this and opened the air valve at this point A on the exhaust stroke, where a partial vacuum is formed, and closed the exhaust valve late as shown at B, Fig. 131, which shows the valve setting for scavenging. Theoretically, this would have the advantage of sweeping the burnt products of combustion away, but in practice the method was not successful and has been practically abandoned.

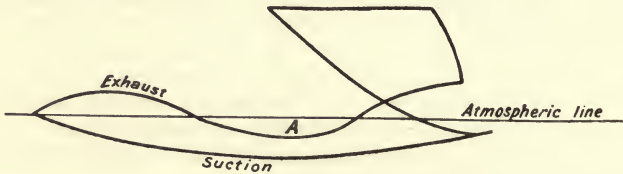

FIG. 130.

The valve setting necessary was adopted by Messrs. Crossleys, and required an exhaust pipe about 65 feet long and a special adjustment of the silencer, which, unfortunately, got out of order with a varying load on the engine. There was introduced, in addition, a higher compression of the charge than usual, and it was doubtless this, rather than the scavenging, which gave the good result obtained with the engine.

The best device is undoubtedly the positive scavenging used on the modern Premier gas engine. In this engine air is compressed in a separate

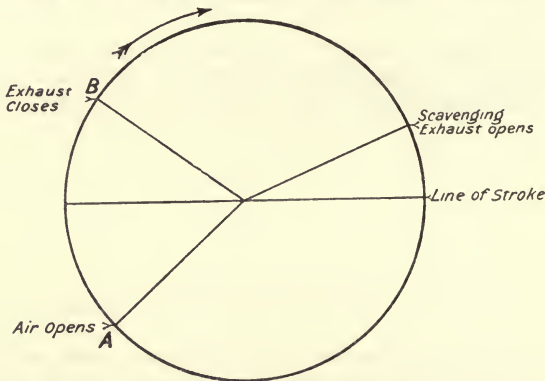

FIG. 131.

pump and forced through the engine cylinder near the end of the exhaust stroke. The approximate valve setting necessary is shown in Fig. 132. The cycle is as follows:—

During the charging stroke air is sucked in by the pump, and in the compression stroke the air, as well as the charge in the engine cylinder, is compressed. The explosion then occurs, and towards the end of the working stroke the exhaust valve opens early. During the compression stroke, just as the piston is turning, the gas valve closes, then the air valve

closes. Towards the end of the exhaust stroke the air valve is opened, and in this last portion of the exhaust stroke the compressed air sweeps across and clears out the burnt products of the previous explosion.

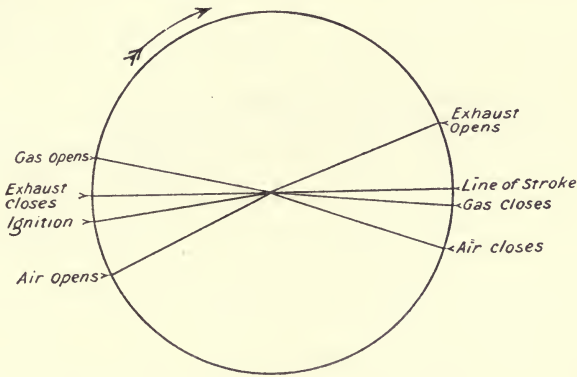

FIG. 132.

Fig. 133 shows the valve setting for the ordinary Otto cycle and should be compared with Fig. 132.

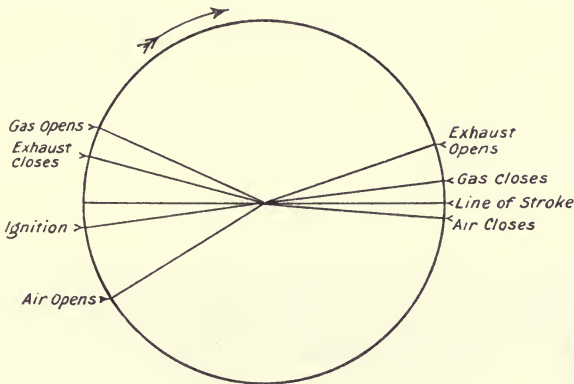

FIG. 133.

170. Ignition in Gas Engines.—In all modern engines the charge is fired either by means of an ignition tube or by an electric spark. The ignition tube consists of a small closed tube of iron or porcelain kept at a bright red heat by means of an external gas flame. It is screwed into the end of the combustion chamber, and the open end is in communication with the engine cylinder. In many cases a timing valve is used with the tube, which opens a communication between the cylinder and the inside of the tube at the correct time for the explosion to occur; in other cases communication is always established and the charge is fired when the compression raises the pressure high enough to cause combustion. On large engines the ignition tubes are usually fitted in pairs, so that if

one bursts the other can be used while the damaged one is repaired; by this the engine is kept running, no stoppage being required for the renewal of the damaged tube. Electric ignition is rapidly replacing tube ignition, the most common method being to use a magneto machine mounted on the engine cylinder, contact being made and broken between the sparking points by means of a rod or lever actuated from the cam shaft of the engine.

171. The Atkinson Cycle Engine.—From theoretical considerations the greatest drawback to the Otto cycle consists in the fact that the ratio of expansion is the same as the ratio of compression. Mr. Atkinson surmounted this difficulty by so arranging the mechanism that he obtained a ratio of expansion twice as great as the ratio of compression, which of course resulted in greater efficiency (Art. 164). With his arrangement he was also able to obtain a working stroke every revolution as against every two revolutions in the Otto cycle engine; this resulted in a more even turning moment, but mechanical difficulties caused the engine to be abandoned.

172. The Clerk or Two-Stroke Cycle.—In this cycle, an indicator diagram of which is shown in Fig. 134, there are only two strokes, the

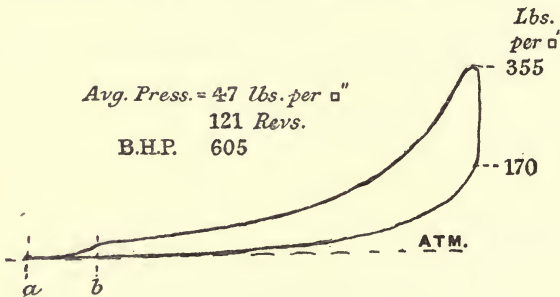

FIG. 134.—Two-stroke cycle.

working stroke and the compression stroke. Towards the end of the working stroke the piston uncovers the exhaust ports in the cylinder walls; air is then admitted under pressure from *b* to *a* and drives out the products of combustion. The explosive mixture of gas and air is next admitted from *a* to *b* and compressed on the return of the piston, and fired as the piston starts to move on its next stroke. By this means one explosion is obtained every revolution of the engine shaft when using one single-acting cylinder, as against one explosion every two revolutions in the four-stroke or Otto cycle. If the cylinder is double-acting there will be an explosion on each side of the piston, every revolution resulting in *two* working strokes per revolution.

The two-stroke has many advantages over the four-stroke cycle. A single-acting cylinder of a certain size arranged as a two-stroke will give approximately twice the power of a cylinder of the same size arranged as a four-stroke, provided that the revolutions per minute are the same. Also an engine of a certain size arranged as a two-stroke will develop the same power as an engine with the same sized cylinders arranged as a four-stroke at half the number of revolutions. This is an important consideration in

marine engines of small power, as a slow-running and more efficient propeller can be adopted with engines of the same weight and cost as the four-stroke type.

The two-stroke engine will run equally well in either direction with adjustment of the ignition. In a four-stroke engine special reversing gear is necessary for the inlet and exhaust valves. In addition to these advantages the two-stroke engine has a more uniform turning moment than the four-stroke, because there is an impulse every revolution; hence a lighter flywheel may be used. Also, the cutting out of an explosion by the governor will have a less disturbing effect on the angular velocity than is the case of the four-stroke engine.

In the two-stroke engine the hot exhaust gases do not pass through a valve but through ports in the cylinder wall, whereas in the four-stroke engine the gases are exhausted through a mechanically operated exhaust valve, which in engines of even moderate size has to be water cooled.

A disadvantage of the two-stroke engine is its slightly lower efficiency. During a portion of the time taken by the explosive mixture to enter the cylinder the exhaust ports are open, and the probability is that some of the gas enters the exhaust pipe, and is therefore wasted, resulting in a larger gas consumption. This, however, is a minor point, because most two-stroke engines are of large size and use cheap fuel gas, such as the waste gas from blast furnaces, etc.

173. Governing.—The methods of governing gas engines may be divided into two classes. In the *quality* method the volume of the charge remains constant and sufficient to fill the engine cylinder as nearly as possible at atmospheric pressure, but the proportion of gas and air in the mixture is varied according to the load on the engine. In the *quantity* method the proportion of gas and air in the mixture is kept constant, but the volume of the charge is varied either by closing the admission valve before the end of the suction stroke, or by throttling; in either case the charge is only sufficient to partly fill the cylinder at atmospheric pressure.

The *quality method* may be subdivided into hit and miss governing; variable gas admission, the gas being admitted uniformly throughout the suction stroke; and variable gas admission caused by opening the gas valve earlier or later during the suction stroke, but always closing it at the end of the stroke. The variation in the strength of the mixture obtained with this method of governing results in explosions of varying intensity, as will be evident on referring to Fig. 135.

The best method to use depends to a large extent on the size and type of the engine, also upon the kind of gas used. The *quality* method is preferable with engines having a considerable weight of reciprocating parts attached to one connecting rod, because under these conditions the inertia of the reciprocating parts should be cushioned by the compression pressure (which in this method is constant), otherwise shock may be caused similar to that experienced in a steam engine working with insufficient compression or lead. The *quantity* method results in a variable compression and is specially suitable for engines with comparatively light reciprocating parts running at a moderate speed, as under these circumstances the reduced compression pressure may be sufficient to take up the inertia forces without shock at the time of ignition.

Variable gas admission caused by opening the gas valve earlier or

later during the suction stroke, but always closing at the end of this stroke, is a most satisfactory method for large engines. By admitting the gas and air in this way, when working at light loads air only is first drawn in, the gas being admitted towards the end of the suction stroke; the result is that the portion of the charge next to the piston contains only a small proportion of gas, whilst that portion near the ignition point has sufficient to form an explosive mixture. This method of governing has come rapidly into use of recent years.

Quality governing by admitting the gas in varying quantities continuously throughout the suction stroke is not generally adopted, although some very large engines have been governed in this way. If the charge is either too rich or too weak it will burn slowly, the combustion continuing throughout the working and exhaust strokes until the commencement of the next suction stroke when the next charge will be ignited as it enters the cylinders, the explosion resulting in burnt products being driven through the open admission valve into the gas and air mains. This may so weaken the next one or two charges drawn into the cylinder that their

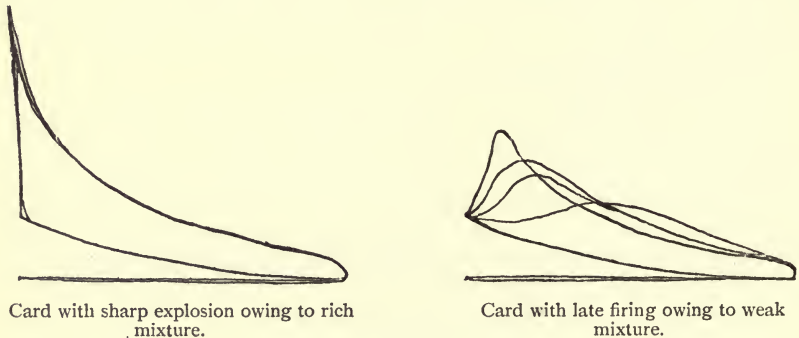

FIG. 135.

working strokes are spoiled. This method can be successfully used when the engine is working at, or nearly at, full load; but for engines which have to govern throughout the full range from full load to no load it is not satisfactory.

Hit and Miss Governing.—In this method the governor allows a full charge of gas to be admitted into the cylinder at normal speed, and cuts off the gas when the speed exceeds a certain limit, making the engine miss one or two explosions. Only air then enters the cylinder, is compressed, expanded and exhausted, by so doing cooling the cylinder and sweeping out the products of combustion. The next explosion is more violent and the turning moment on the crankshaft is very irregular. To keep the speed steady it is necessary to put on heavy flywheels and to run at high speeds on account of the fluctuation in the violence and number of explosions. As regards gas consumption this is the most economical method.

A small block having a V groove cut in it is suspended between the end of the gas valve spindle and the striker which is driven from the cam

shaft of the engine. The end of this striker forms a knife-edge which fits into the **V** groove in the block when the engine speed is not above its normal value and so opens the gas valve. A very small movement of the block results in the striker missing the block on its next stroke and the gas valve is not opened. The block is moved by the governor, and for very close governing the governor decides whether there is to be a "hit" or a "miss" by a very small movement of the block, in some cases the thickness of the knife-edge. The governor itself, therefore, always governs when in one position, and it does not matter if it is very far from being isochronous (Art. 256); also, as it has very little work to do, the parts to move being very light and having very little resistance to overcome, a very small governor will effectually control a large engine. Unfortunately, hit and miss governing is scarcely suitable for large engines, owing to the inadvisability of opening a large and therefore heavy gas valve by means of a knife-edge, and to the uneven turning movement which necessitates the use of very heavy flywheels to keep the speed as uniform as desired.

Quantity Governing.—The quantity method of governing may be divided into throttle governing and cut-off governing. The latter method frequently necessitates some form of trip arrangement which requires a heavy and powerful governing gear, resulting in noisy working and considerable wear and tear. The most common methods are to govern by throttling the mixture in the inlet pipe to the engine cylinder, or else to vary the lift of the admission valve. One objection to all kinds of quantity governing is that very strong springs are required on the admission and exhaust valves, as frequently the pressure towards the end of the suction stroke is as low as 9 pounds per square inch below atmospheric. Gas engine valves invariably open inwards, and a large valve requires a strong spring to prevent its being opened by a suction of 9 pounds; on the Continent the throttle system is usually used.

It should be remembered that practically all large gas engines work on producer gas which is of low heating value and slow to ignite. With weak mixtures combustion is impossible unless the compression pressure is fairly high; if, therefore, the engine is governed on the quantity method it is important that the compression should be high enough with a full load charge to ensure its being high enough for a low load charge.

174. Study of the Indicator Diagram. Determination of the Laws of the Expansion and Compression Curves from the Indicator Diagram.—The expanding gases follow the law $p v^n = \text{constant}$; the problem under discussion is to find the value of the index " n " from the indicator diagram.

Let $p v^n = c$

Then taking logs we have

$$\log p + n \log v = \log c = \text{constant}$$

This is the equation of a straight line. If, therefore, this equation be plotted on squared paper and a straight line be drawn lying evenly between the plotted points, the errors of measurement will be eliminated and the value of " n " found. The method will be best illustrated by means of an actual example.

Fig. 136 shows an average indicator diagram taken from a 25 B.H.P. Campbell gas engine working on suction gas. Diagrams were taken every 10 minutes during a trial lasting 6 hours, from which the average diagram shown in the Fig. 136 was plotted on squared paper.

The cylinder was 9.5 inches diameter and the stroke 19 inches, therefore the piston displacement or stroke volume is

$$0.7854 \times (9.5)^2 \times 19 = 1346.7 \text{ cubic inches}$$

The clearance volume was 272 cubic inches.

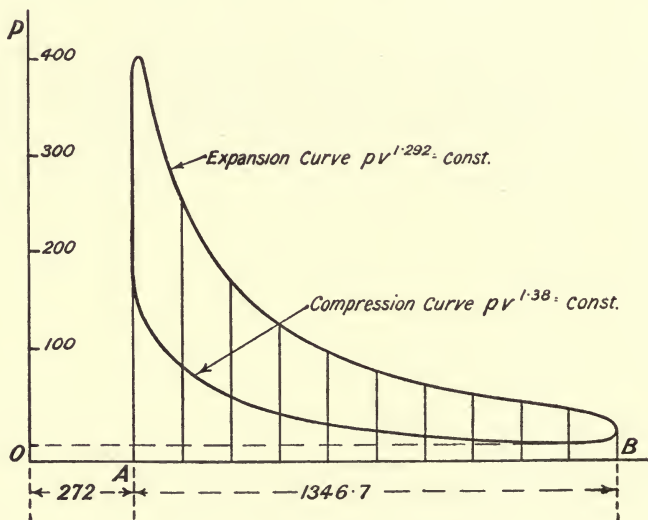

FIG. 136.

In plotting the diagram (Fig. 136) the length AB representing the stroke was made 5 inches, hence 1 inch represents $\frac{1346.7}{5} = 269.34$ cubic inches. Set off the vertical OP representing zero volume so that AO represents the clearance volume of 272 cubic inches, *i.e.* $AO = \frac{272}{269.34}$ or 1.01 inch. The volume of the gas is proportional to the length of cylinder it occupies, hence we may write

$$p l^n = \text{constant}$$

where l represents the length on the diagram measured from OP. Next divide the diagram into any number of parts by the ordinates as shown and tabulate the *absolute* pressures " p " corresponding to the lengths " l ." The results obtained for the expansion curve are as follows:—

Pounds per square inch absolute.	l inches.	$\log p$.	$\log L$.
273	1'59	2'4362	0'2014
185	2'09	2'2672	0'3201
145	2'59	2'1614	0'4133
113'5	3'09	2'0550	0'4900
93	3'59	1'9685	0'5551
78'5	4'09	1'8949	0'6117
68	4'59	1'8325	0'6618
60	5'09	1'7782	0'7067
53	5'59	1'7243	0'7474

Next plot $\log p$ and $\log l$ as shown in Fig. 137; the slope of the line

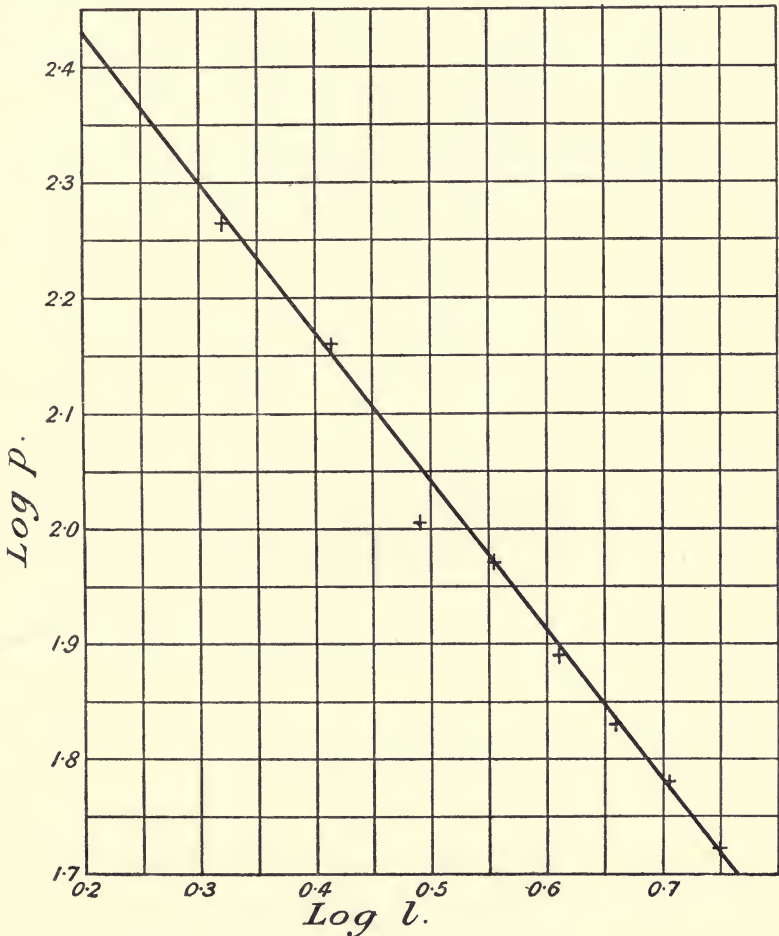

FIG. 137.

so obtained gives the value of "n." Reading from this line we find that for an increase in $\log p$ of $(2.43 - 1.70)$ or 0.73 , the corresponding increase in $\log l$ is $(0.765 - 0.20)$ or 0.565

hence
$$n = \frac{0.73}{0.565} = 1.292$$

The law of the expansion curve is therefore $pv^{1.292} = \text{constant}$. In exactly the same way the law of the compression curve is found to be $pv^{1.38} = \text{constant}$.

Now this engine was working with a mixture for which γ may be taken as 1.38. It is obvious, therefore, that the expansion curve lies *above* the adiabatic $pv^{1.38} = \text{constant}$, hence on our assumption that the specific heat of the working gases remains constant, the gas must be receiving heat during the expansion (Art. 14). But we know that the gases are losing heat to the water jacket, hence if their specific heat remains constant, the only conclusion to be drawn is that combustion takes place throughout the greater part of the expansion stroke, and that more heat is being supplied to the gas during the expansion than is lost to the cylinder walls, that is to say, we have after burning, which has been discussed in Art. 167.

The following is a rough method of determining the laws of the expansion and compression curves *when the clearance volume is not known*.

175. Approximate Method of finding the Clearance Volume and the Index "n" of "pv" from the Indicator Diagram.—Let

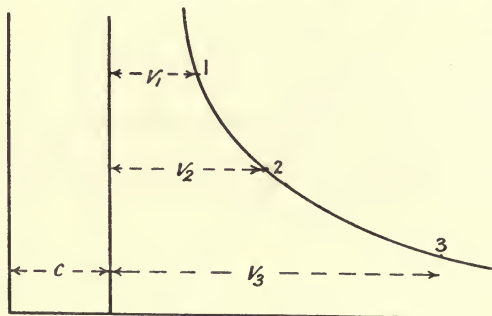

FIG. 138.

Fig. 138 represent the expansion curve. On a smooth portion of the curve take any two points 1 and 3, and choose an intermediate point 2 such that $p_2 = \sqrt{p_1 p_3}$, or

the pressure at 2 is the geometric mean of the pressures at 1 and 3

Let

$c = \text{clearance (to be found)}$

$p_1 v_1 = \text{pressure and volume at point 1}$

$p_2 v_2 = \text{ " " " " 2}$

$p_3 v_3 = \text{ " " " " 3}$

Then, since

$$p_2 = \sqrt{p_1 p_3}$$

$$\therefore \frac{p_2}{p_1} = \frac{p_3}{p_2} = \text{constant} = k \text{ say } \dots \dots (1)$$

If “ v ” is the indicated volume, then

Law of curve is $p(v + c)^n = \text{constant} = b$ say

$$\therefore p^{\frac{1}{n}}(v + c) = b^{\frac{1}{n}} \dots \dots \dots (2)$$

or
$$v = -c + b^{\frac{1}{n}} p^{-\frac{1}{n}} \dots \dots \dots (3)$$

Writing $m = \frac{1}{n}$ for convenience, we have the volumes at points 1, 2, and 3 are—

$$v_1 = -c + b^m p_1^{-m} \dots \dots \dots (4)$$

$$v_2 = -c + b^m p_2^{-m} \dots \dots \dots (5)$$

$$v_3 = -c + b^m p_3^{-m} \dots \dots \dots (6)$$

From (5) and (6) we have

$$v_3 - v_2 = b^m (p_3^{-m} - p_2^{-m}) \dots \dots \dots (7)$$

From (4) and (5) we have

$$v_2 - v_1 = b^m (p_2^{-m} - p_1^{-m}) \dots \dots \dots (8)$$

Hence from (7) and (8)

$$\frac{v_3 - v_2}{v_2 - v_1} = \frac{p_3^{-m} - p_2^{-m}}{p_2^{-m} - p_1^{-m}} \dots \dots \dots (9)$$

But by (1)

$$p_3 = k p_2$$

and

$$p_2 = k p_1$$

∴ Substituting these values of p_3 and p_2 in (9) we have—

$$\begin{aligned} \frac{v_3 - v_2}{v_2 - v_1} &= \frac{k^{-m} p_2^{-m} - p_2^{-m}}{k^{-m} p_1^{-m} - p_1^{-m}} \\ &= \frac{p_2^{-m} \{k^{-m} - 1\}}{p_1^{-m} \{k^{-m} - 1\}} \\ &= \left(\frac{p_2}{p_1}\right)^{-m} = \left(\frac{p_1}{p_2}\right)^m = k^{\frac{1}{n}}. \\ \therefore \frac{v_3 - v_2}{v_2 - v_1} &= k^{\frac{1}{n}} \dots \dots \dots (10) \end{aligned}$$

Taking logs we have

$$\log \frac{v_3 - v_2}{v_2 - v_1} = \frac{1}{n} \log k$$

or

$$n = \frac{\log k}{\log \frac{v_3 - v_2}{v_2 - v_1}} \dots \dots \dots (11)$$

Equation (11) gives “ n ” in terms of $k = \frac{p_2}{p_1} = \frac{p_3}{p_2}$ and $v_3, v_2,$ and $v_1,$ all of which are known.

To find the Clearance.—Plot v vertically and $p^{-\frac{1}{n}}$ horizontally, then by equation (3) above the intercept on the axis of “ y ” will give the clearance

" c " as shown in Fig. 139, equation (3) being the equation to a straight line. The Author has tested this method repeatedly on diagrams taken on various

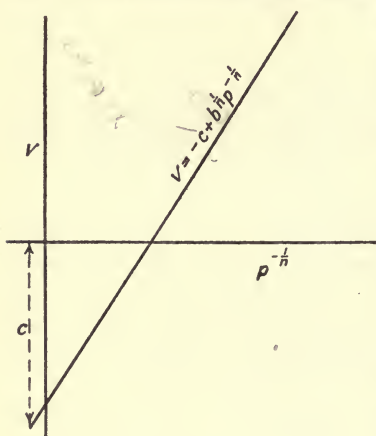

FIG. 139.

gas and oil engines, and found that by careful working the clearance volume can be obtained within three per cent. of the actual measured volume; it is not very reliable, however, on small scale diagrams on account of the errors of observation of the pressures and volumes, and as only three points are taken these errors will not be eliminated as well as in the usual method of Art. 174, where any number can be taken (the more the better).

176. Rate of Heat Reception and Rejection from the Indicator Diagram.—In Art. 14 it has been shown that the rate of heat

reception $\frac{dH}{dv}$ is given by

$$\frac{dH}{dv} = p \cdot \frac{\gamma - n}{\gamma - 1}$$

If γ and n are known $\frac{dH}{pv}$ can be calculated.

EXAMPLE.—Let the law of the expansion curve be $pv^{1.479} = 145.5$, and the law of the compression curve $pv^{1.304} = 39.36$, and let $\gamma = 1.37$ for the products of combustion, and $\gamma = 1.385$ for the mixture.

Then for the expansion curve

$$\frac{dH}{dv} = p \cdot \frac{1.37 - 1.479}{0.37} = -\frac{0.109}{0.37} p = -0.2946p$$

This shows that the gas is losing heat throughout the expansion, since $\frac{dH}{dv}$ is negative.

Similarly for the compression curve

$$\frac{dH}{dv} = -p \times \frac{1.385 - 1.304}{0.385} = -0.2104p$$

Therefore the gas is losing heat throughout the compression as well as throughout the expansion.

177. Method of Calculating the Temperature at any point of the Indicator Diagram.—The following method,¹ due to Professor John Perry, is based on the assumption that the specific heats of the gas are constant, and that the gas follows the law:—

$$\frac{pv}{T} = R = C_p - C_v \text{ for a perfect gas}$$

$$\text{or } \frac{p_1 v_1}{T_1} = \frac{p_2 v_2}{T_2} = \frac{p_3 v_3}{T_3} \text{ etc.}$$

¹ See *Phil. Mag.*, July, 1884.

Knowing the pressure, volume and temperature at any point on the diagram, and the pressure and volume at another point from the diagram, the temperature at that point is easily calculated. The value of $\frac{pv}{T}$ is found from the point on the diagram at the end of the charging stroke, just before compression begins.

EXAMPLE.—The diagram shown in Fig. 140 was taken from a 20 B.H.P. Campbell gas engine in the Engineering Laboratory of the University College, Nottingham. Given, diameter of cylinder $9\frac{1}{2}$ inches, stroke 19 inches, clearance volume 272 cubic inches, barometric pressure 15 lbs. per square inch, temperature at beginning of compression 180° F., $C_p = 0.24$, $C_v = 0.17$, law of expansion curve $pv^{1.292} = \text{const.}$, calculate: (a) the temperatures at A and B; (b) the heat given to or taken from the gases between A and B; (c) the rate of heat reception between A and B.



FIG. 140.

$$(a) \text{ Clearance volume} = 272 \text{ cubic inches } \frac{272}{1728} = 0.157 \text{ cubic foot}$$

$$\text{Piston displacement} = \frac{0.7854 \times (9.5)^2}{144} \times \frac{19}{12} = 0.779 \text{ cubic foot}$$

$$\therefore \text{Volume at beginning of compression} \left. \vphantom{\begin{matrix} \text{of compression} \\ \end{matrix}} \right\} = 0.157 + 0.779 = 0.936 \text{ cubic foot}$$

From the diagram

$$v_A = 0.157 + 0.023 = 0.180 \text{ cubic foot}$$

$$p_A = 475 + 15 = 490 \text{ lbs. per square inch absolute}$$

$$v_B = 0.157 + 0.719 = 0.876 \text{ cubic foot}$$

$$p_B = 50 + 15 = 65 \text{ lbs. per square inch absolute}$$

$$\therefore \frac{pv}{T} = \frac{p_A v_A}{T_A}$$

$$\text{i.e. } \frac{15 \times 144 \times 0.936}{180 + 460} = \frac{490 \times 144 \times 0.18}{T_A}$$

$$\therefore T_A = \frac{490 \times 0.18 \times 640}{15 \times 0.936} = 4026^\circ \text{ abs.} = 3565^\circ \text{ F.}$$

$$\text{Also } \frac{15 \times 0.936}{640} = \frac{65 \times 0.876}{T_B}$$

$$\therefore T_B = \frac{640 \times 65 \times 0.876}{15 \times 0.936} = 2599^\circ \text{ abs.} = 2138^\circ \text{ F.}$$

\therefore calculated temperature (maximum) at A = 3565° F.

” ” ” B = 2138° F.

(b) The law of the expansion curve by the method of Art. 174 is found to be $pv^{1.292} = \text{constant}$.

By equation (5), Art. 14, the heat added during expansion is—

$$H = \text{work done} \times \frac{\gamma - n}{\gamma - 1}$$

In this example $\gamma = \frac{C_p}{C_v} = \frac{0.24}{0.17} = 1.41$

and work done from A to B = $\frac{p_A v_A - p_B v_B}{n - 1}$ foot-pounds

$$= \frac{490 \times 0.18 - 65 \times 0.876}{1.292 - 1} \times 144$$

$$= \frac{88.20 - 56.94}{0.292} \times 144 = \frac{31.26 \times 144}{0.292}$$

$$= 15,430 \text{ foot-pounds}$$

$$= \frac{15,430}{778} = 19.85 \text{ B.Th.U.}$$

$$\therefore \text{heat added} = 19.85 \times \frac{1.41 - 1.292}{0.292}$$

$$= + 19.85 \times \frac{0.118}{0.292} = 7.75 \text{ B.Th.U.}$$

Hence heat supplied as during expansion from A to B = 7.75 B.Th.U.

(c) Rate of heat reception $\frac{dH}{dv} = p \times \frac{1.41 - 1.292}{0.292} = 0.405p$.

The value of the constant $\frac{pv}{T}$ can also be inferred from the weight of the gas in the cylinder as follows :—

Let V_g = volume of gas (in cubic feet) admitted per stroke at absolute temperature T_g , and absolute pressure P_g .

V_a = volume of air (in cubic feet) admitted per stroke at absolute temperature T_a and absolute pressure P_a .

V_e = volume of the exhaust gases (in cubic feet) remaining in the cylinder at the end of the exhaust stroke at absolute temperature T_e , and absolute pressure P_e .

Reducing these to N.T.P., *i.e.* 492° F. absolute, and 2116 pounds per square foot, the total volume in the cylinder at N.T.P. will be

$$V_0 = \frac{T_0}{P_0} \left(\frac{P_g V_g}{T_g} + \frac{P_a V_a}{T_a} + \frac{P_e V_e}{T_e} \right) \quad \dots (1)$$

If w_g , w_a , w_e be the densities of the gas, air, and exhaust gases in pounds per cubic foot at N.T.P., the total weight of the contents of the cylinder will be

$$W = \frac{T_0}{P_0} \left(\frac{w_g P_g V_g}{T_g} + \frac{w_a P_a V_a}{T_a} + \frac{w_e P_e V_e}{T_e} \right)$$

or since

$$T_0 = 492 \quad \text{and} \quad P_0 = 2116$$

$$W = 0.233 \left(\frac{w_g P_g V_g}{T_g} + \frac{w_a P_a V_a}{T_a} + \frac{w_e P_e V_e}{T_e} \right) \quad \dots (2)$$

Hence, the volume of 1 pound of the cylinder contents will be

$$v_0 = \frac{V_0}{W} \dots \dots \dots (3)$$

$$\therefore R = \frac{P_0 V_0}{T_0} = \frac{V_0}{0.233W} \text{ or } 4.292v_0 \dots \dots \dots (4)$$

Hence, for the contents of the cylinder we have

$$pv = 4.292 v_0 \times T \dots \dots \dots (5)$$

from which the temperature at any point in the cycle can be estimated.

The value of T_g may be taken as the mean temperature of the exhaust gases which can be measured directly; the weight w_e may be calculated from the proportion of air and gas used.

178. Temperature-Entropy Diagram for the Ideal Otto Cycle.—

The temperature-entropy diagram corresponding to the indicator diagram (Fig. 126) is shown in Fig. 141. The line BC, Fig. 141, represents the adiabatic compression, the rise in temperature being BC. The temperature at the instant compression begins, namely at B, may be approximately taken as the maximum temperature of the jacket water leaving the cylinder, hence points B and C are fixed on the $T\phi$ diagram.

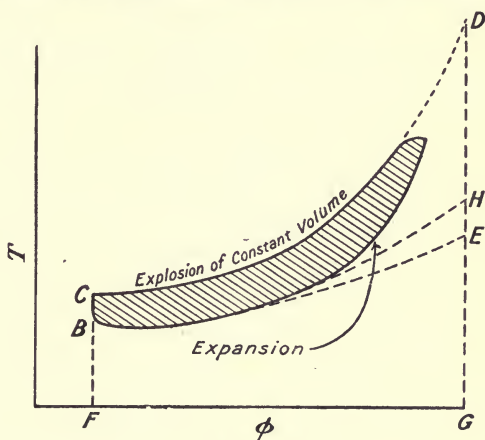

FIG. 141.

The explosion at constant volume gives the gain of entropy along CD, the curve CD being plotted from the equation

$$\phi_2 - \phi_1 = C_v \log_{\epsilon} \frac{T_2}{T_1} \text{ (Art. 16, equation (11))}$$

assuming C_v to be constant.

In the case of the ideal diagram when the gases expand down to atmospheric pressure, the line DE represents the fall in temperature during the adiabatic expansion, while the line EB represents the constant-pressure atmospheric line plotted from the equation

$$\phi_2 - \phi_1 = C_p \log_{\epsilon} \frac{v_2}{v_1} = C_p \log_{\epsilon} \frac{T_2}{T_1} \text{ (Art. 16, equation (12))}$$

For the ideal pv diagram (expansion down to atmospheric pressure) the $T\phi$ diagram is therefore BCDE, Fig. 141, and

heat produced by the explosion = area FCDG
 heat rejected to exhaust = area FBEG
 work done = area FCDG — area FBEG = area BCDE

Hence efficiency = $\frac{\text{area BCDE}}{\text{area FCDG}}$

When the ratios of expansion and compression are equal, as in the Otto cycle, DH represents adiabatic expansion, DH being the fall of temperature during the expansion, and HB represents the exhaust stroke, while

$$\text{efficiency} = \frac{\text{area BCDH}}{\text{area FCDG}}$$

The actual $T\phi$ diagram corresponding to an indicator diagram taken from an engine is represented by the shaded area in Fig. 141, since, as already mentioned, the maximum temperature reached in the cylinder falls short of the calculated temperature of combustion, and also the expansion is not adiabatic.

179. Method of drawing the Temperature-Entropy Diagram from the Indicator Diagram.—An indicator diagram taken from a

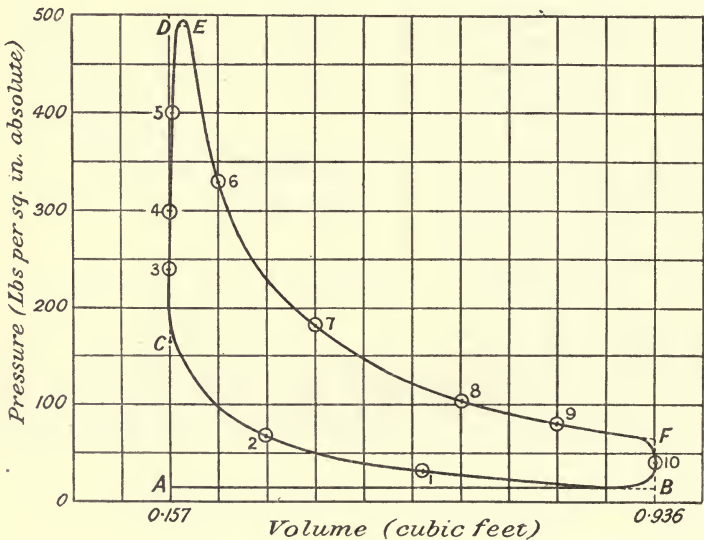

FIG. 142.

25 B.H.P. Campbell gas engine working on coal gas is shown in Fig. 142. The law of the expansion curve as determined by the method of Art. 174 is $p v^{1.29} = \text{constant}$, and of the compression curve $p v^{1.38} = \text{constant}$. The temperature at the end of the suction stroke at B is assumed to be 100°C . or 212°F ., i.e. $212 + 460 = 672^{\circ}\text{absolute}$, and $C_p = 0.28$, $C_v = 0.201$.

The probable temperature of the working substance at different points on the indicator diagram is calculated by the method of Art. 177. Starting at point B, where the pressure is 15 pounds per square inch absolute, temperature $672^{\circ}\text{absolute}$, and volume 0.936 cubic foot, we have

$$\frac{p v}{T} = \frac{15 \times 0.936}{672} = \text{constant} = 0.0208$$

and the temperature at any point where the absolute pressure in pounds per square inch is p' and volume is v' cubic feet is given by

$$T' = \frac{p'v'}{0.0208} \text{ absolute}$$

The calculated temperatures at different points on the indicator diagram are shown in the table on p. 302.

The entropy of the mixture at point B, reckoned from 32° F. , *i.e.* 492° absolute, is

$$C_p \log_e \frac{672}{492}$$

or $0.28 \times 2.303 \log_{10} \frac{672}{492} = 0.087 \text{ unit}$

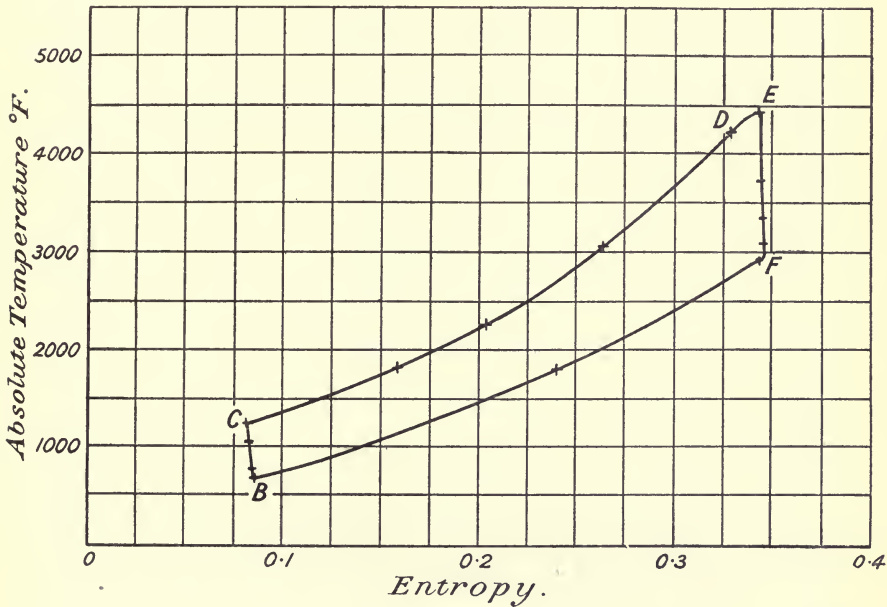

FIG. 143.

The entropy at different points on the compression and expansion curves is calculated from the equation

$$\text{Gain of entropy } (\phi_2 - \phi_1) = C_v \frac{\gamma - n}{n - 1} \log_e \frac{T_1}{T_2} \text{ (Art. 16 (13))}$$

The entropy at different points on the explosion line CD and during release FB is calculated from

$$\phi_2 - \phi_1 = C_v \log_e \frac{T_2}{T_1} \text{ (Art. 16 (11))}$$

The results obtained are shown in the table below; plotting columns 4 and 6 gives the temperature-entropy diagram shown in Fig. 143.

The above is a long and rather intricate method of drawing the temperature-entropy diagram from the pressure-volume diagram, but is given here because it is worked from first principles only. For practical work Captain H. Riall Sankey's method is preferable.¹

	Point on p/v diagram.	Pressure, lbs. per sq. in. absolute.	Volume, cubic feet.	Absolute temperature, ° F.	Change in entropy.	Entropy reckoned from 32° F.
Compressive curve $p v^{1.38} = \text{constant}$	B	15	0.936	672	—	0.0868
	1	30	0.510	735	0.0004	0.0864
	2	67	0.320	1030	0.0022	0.0846
	C	165	0.157	1245	0.0032	0.0836
Explosion at constant volume	3	240	0.157	1811	0.0749	0.1585
	4	300	0.157	2264	0.120	0.2036
	5	400	0.157	3072	0.181	0.264
	D	490	0.160	4240	0.246	0.329
	E	490	0.190	4476	0.0151	0.344
Expansion curve $p v^{1.29} = \text{constant}$	6	330	0.234	3712	0.0013	0.345
	7	180	0.388	3357	0.0019	0.346
	8	105	0.621	3134	0.0024	0.346
	9	80	0.790	3038	0.0026	0.347
Release at constant volume	F	65	0.936	2924	0.0029	0.344
	10	40	0.936	1800	0.019	0.240
	B	15	0.936	672	0.260	0.087

180. Losses in Gas Engines.—The total amount of heat supplied during the explosion may be accounted for in three parts, namely—

1. Heat converted into work.
2. Heat carried away in the exhaust gases.
3. Heat lost during expansion.

For the methods by which the above are measured the reader is referred to Chapter XVI. ; for the present we are only concerned with the problem of reducing the losses and thereby increasing the efficiency. Almost all modern gas engines are of the *constant volume* type discussed in Art. 163,

¹ *Proc. Inst. Mech. Eng.*, May, 1906. A direct graphical method will also be found in *Proc. Inst. Mech. Eng.*, Feb. 1908.

in which the ratios of compression and expansion are equal, and considering this type of engine, we have the unavoidable loss in the exhaust gases resulting from incomplete expansion. As we have already seen (Art. 164), Mr. Atkinson reduced this loss by carrying the expansion down to a much lower pressure, but mechanical difficulties caused this engine to be abandoned. The same result would also be obtained by employing *compound* expansion, in which the gases from the high-pressure or explosion cylinder are exhausted into a larger low-pressure cylinder, exactly in the same way as the expansion of steam is carried out in a compound steam engine. With the modern engine, therefore, the loss due to exhausting with high pressure at release cannot be materially reduced.

The very high temperature attained during the explosion results in a very rapid extraction of heat by the cylinder walls. The higher the temperature the more rapid is this loss to the water-jacket through the cylinder walls. Any suitable method, therefore, which has for its object the reduction of the maximum temperature reached in the engine cylinder, without decreasing the mean pressure during the cycle, should be beneficial in reducing this loss and in raising the efficiency. Two methods have been tried in practice, the water injection method and the super-compression method.

The Water Injection Method.—This method, adopted by Messrs. Crossley, consists in injecting a fine spray of water into the engine cylinder during the suction stroke. The water entering in this manner with the air supply does not form a water film on the cylinder walls, but is distributed throughout the cylinder contents in the form of a mist, only a very small quantity of water being necessary. When the mixture explodes the water mist is evaporated into steam, and its latent heat so absorbed prevents the temperature rising too high.

The Super-Compression Method.—This method, due to Mr. Dugald Clerk,¹ may be described in his own words as follows:—

“Some time ago it appeared to me possible to reduce the maximum temperature by increasing the charge-weight per stroke given to an engine. I had experimented with two engines, one having a 7-inch cylinder, 15 inches stroke, and the other a 10-inch cylinder, 18 inches stroke. These engines, which are of the ordinary standard four-stroke type, are allowed to take in the usual charge of gas and air; then at the end of the stroke a further charge of air or inert fluid is added to increase the pressure in the cylinder to 7 or 8 pounds per square inch above atmospheric before the return of the piston. A small part of the return stroke is, however, made before the pressure can be materially increased, as the added charge takes some time to fill the cylinder. This has the effect of increasing the charge weight present in the cylinder by about 40 per cent., and of increasing the pressure of compression without, however, increasing the temperature of compression. Indeed, in both experiments the temperature of compression was diminished. As the charge present is constant so far as gas is concerned, the maximum temperature capable of being produced is much reduced. The maximum temperature shown by the diagrams taken by me from these two engines is about 1200° C. Experiments were made, and it was found that the heat flow

¹ James Forest Lectures, Inst. of Civil Engineers (1904).

was reduced to about two-thirds, and further that the mean available pressure was increased about 20 per cent."

It is very fortunate that a reduction in the maximum temperature reached in the engine cylinder results in a higher efficiency, because a lower temperature also results in greater freedom from over-heating and the cracking of cylinders and pistons due to the temperature stresses set up in the material. The higher efficiency thereby obtained results in increased reliability in working, which is more important to the manufacturer than economy of fuel.

181. The Standard Cycle to be used for comparing the Performances of Internal Combustion Engines.—There is great diversity of opinion upon the best cycle to be used. It has been shown definitely (Chap. XIV.) that the specific heats of gases are *not* constant, but increase at the high temperatures attained in the engine cylinder. This being so, it can hardly be considered fair to compare the engine with the *air standard* efficiency given in Art. 163, namely $1 - \left(\frac{1}{r}\right)^{\gamma-1}$. It is equally unfair to compare the engine with the Carnot cycle, in which the efficiency is $\frac{T_1 - T_2}{T_1}$ (Art. 21). An unavoidable cause of loss of efficiency lies in the fact that *all* the heat is not supplied to the working substance at the maximum temperature, but some is supplied between the temperature at the end of compression and T_1 , the maximum temperature of combustion. As suggested by Professor J. A. Ewing,¹ it seems, therefore, a fairer comparison to take the ideal standard of performance as that of an engine in which combustion takes place between two defined temperatures and in which the action is reversible in all other respects. (Compare the ideal Rankine cycle for the steam engine, Art. 55.) The ideal efficiency, taking into account the variable specific heat of the working substance, is considered separately in Art. 190.

Let T_0 be the absolute temperature of the gases before ignition, *i.e.* at the end of compression,

T_2 the absolute temperature of exhaust,

T_1 the maximum temperature at which, in the ideal case, combustion is supposed to be complete,

then, assuming the specific heat to remain constant, if δH be a small quantity of heat supplied during combustion over a small range of temperature δT or $T - T_2$, the greatest amount of work that can be done per pound of working substance will be

$$\delta H \times \frac{T - T_2}{T} \quad \text{or} \quad C_v \frac{dT}{T} (T - T_2)$$

and the total work done will be

$$C_v \int_{T_0}^{T_1} \frac{dT}{T} (T - T_2)$$

or $C_v(T_1 - T_0) - C_v \cdot T_2 \log_e \frac{T_1}{T_0} \dots \dots \dots (1)$

¹ "The Steam Engine and other Heat Engines," 2nd edition, p. 434.

The total quantity of heat supplied during combustion will be

$$C_v(T_1 - T_0)$$

Hence the ideal efficiency will be

$$\begin{aligned} & \frac{\text{Heat converted into work}}{\text{Heat supplied}} \\ &= \frac{C_v(T_1 - T_0) - C_v \cdot T_2 \log_e \frac{T_1}{T_0}}{C_v(T_1 - T_0)} \\ &= 1 - \frac{T_2}{T_1 - T_0} \log_e \frac{T_1}{T_0} \dots \dots \dots (2) \end{aligned}$$

The Committee of the Institution of Civil Engineers on the Efficiency of Internal Combustion Engines in their Report¹ recommend the continued use of the air standard efficiency on account of its simplicity, recognising as they do the uncertainty attached to the values of the specific heats of the gases at high temperatures. (See also Art. 190.)

182. Theories advanced to explain how it is that the Expansion Curve on the Gas Engine Indicator Diagram frequently lies above the Adiabatic.—Considering the great amount of heat taken from the gases by the water jacket during expansion, it might be expected that the expansion curve will always be *below* the adiabatic. In many cases, particularly in modern engines in which the maximum explosion temperature is very high (the example worked out in Art. 177, for instance), the curve actually is less steep and lies *above* the adiabatic. Various theories have been advanced to explain this phenomenon, the following being the principal ones.

1. *Action of the Cylinder Walls.*—It has been suggested that the cooling action of the cylinder walls is sufficient to cause slow combustion. It is very doubtful, however, that this is the case; but admitting it to be true, this action of the cylinder walls would have the effect of keeping the temperature of combustion below the theoretical temperature expected, and also, the combustion not being instantaneous, but gradual, will cause the pressure to be kept up during the expansion on account of the heat supplied during the combustion taking place on expansion.

2. *After Burning.*—Admitting that “after burning” or retarded combustion takes place (as discussed in Art. 167), the effect would be the same as the above, only much more pronounced.

3. *The Specific Heat of the Gas is not Constant.*—This is probably the best explanation of the phenomenon. It is well known that the specific heat increases with increasing temperature, and applying this fact to the study of the curve the phenomenon is explained. Fig. 144 shows an indicator diagram on which the adiabatic 1 has been drawn on the assumption of constant specific heat, and the adiabatic 2 on the assumption of variable specific heat. It will be noticed that the actual expansion curve which follows the law $p v^{1.461} = \text{constant}$ lies very close to the adiabatic for constant specific heat (in very many cases it lies well above this adiabatic, as before mentioned). The expansion curve, however, lies very much below the adiabatic

¹ Proc. Inst. C. E., vol. clxiii., 1905-1906, p. 241.

drawn on the assumption of variable specific heat, and on this hypothesis the gases must be losing heat during expansion.

The diagram shown in Fig. 144 is taken from the Second Report of the Gas Engine Research Committee,¹ and in that report it is proved that the assumption of variable specific heat shows that in all cases the expansion curve lies below the adiabatic, as would be expected. This theory explains the phenomenon without admitting that after burning or retarded combustion takes place. The theory of the gas engine on the assumption of variable specific heat is given in Art. 190.

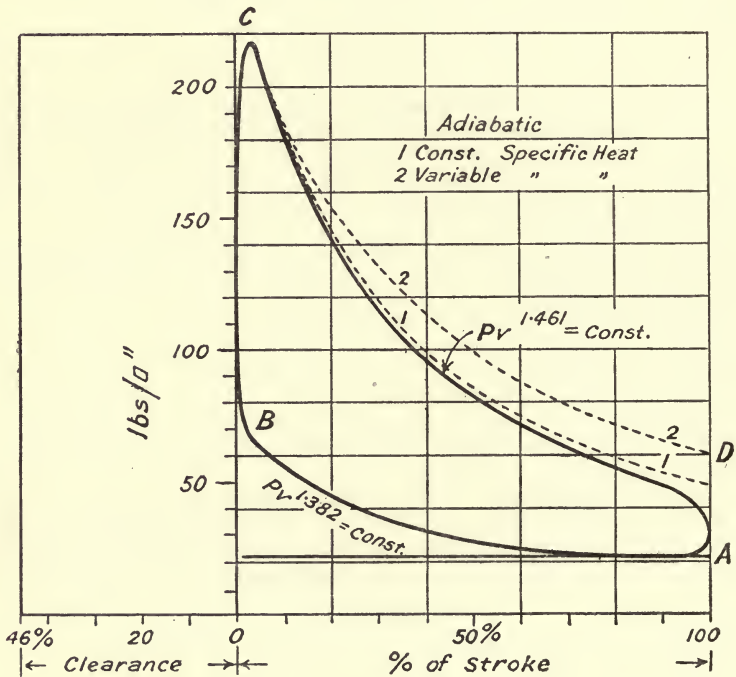

FIG. 144.

183. Heat Transmission through the Cylinder Walls.²—The rate of heat-flow from the gas to any part of the walls at any instant depends upon the then temperature density and motion of the gas, and also upon the temperature and condition of the wall surface. It will therefore differ widely at different points of the working stroke, and by far the greater part of the heat-flow will occur in a very short time immediately after ignition and pass into the surface of the combustion chamber and piston and valves; comparatively little will pass into the barrel of the cylinder, since it is not uncovered by the piston until the density and temperature of the gas have fallen. Mr. Dugald Clerk³ has found that the average heat-flow

¹ *Proc. Inst. Mech. Eng.*, 1901, p. 1031.

² See also the "Fifth Report of the Gaseous Explosions Committee," B. A., 1912.

³ *Proceedings Royal Soc., A.*, vol. lxxvii. (1906), p. 500.

per square foot per second in the first three-tenths of the working stroke is three times that of the average over the whole stroke for equal temperature differences, and he calculates that the actual rate of heat-flow in the first three-tenths of the stroke is *six* times that of the whole stroke in ordinary gas engines working at full load.

In order that the heat may be conducted away through the walls at the required rate there must be a certain temperature gradient in the metal (Art. 151) and a corresponding mean surface temperature. The cyclic variation in temperature above and below the mean (Art. 68) will not be very large with a *clean* metallic surface; Professor Coker found a total cyclic variation of 7° C. at a depth of 0.015 inch in the wall of the combustion chamber of an engine running at 240 revolutions per minute. The chief problem in the design of large gas (and oil) engines is to prevent the temperature of the walls from rising too high and causing pre-ignitions, and also to prevent the metal from getting overstrained by unequal expansion, particularly at places where the metal wall is thick, as for example at the head of an ordinary flat-faced piston; in this case the central portion will get very much hotter than the edge, which will therefore be put in tension, and to minimise these evils it is essential to cool the piston by water circulation.

*Radiation from the Gas.*¹—The law of radiation given by Stefan and Boltzmann (Art. 158) has been confirmed for gaseous explosions by W. T. David,² who found that the rate of loss from this cause varies roughly as the fourth power of the absolute temperature. A large proportion of the heat loss through the walls is radiated directly from the hot gas, and it is evident that the rapid reduction in temperature consequent upon expansion results in comparatively little radiant heat reaching the barrel of the cylinder (see above).

“An important practical consequence of radiation is the greatly increased loss of heat which occurs when the mean pressure in an engine is increased by increasing the strength of the mixture; the jacket loss and the metal temperatures are raised in a much greater proportion than the fuel consumption and the efficiency is diminished. In very large engines this sets a fairly sharp limit to the possible output, which is, as a rule, considerably less than the maximum of which the engine would be capable if it were given all the fuel it could take. If the load be in excess of this limit the engine overheats rapidly in consequence of the greatly increased heat-flow.”³

The size of the cylinder will also have an effect on radiation, the greater the depth of hot gas (up to a certain value) the greater will be the amount of radiant heat reaching the walls. For this reason the difficulty of designing and working large engines is not only due to the greater thickness of metal required but also to the greater flow of heat.

Effect of the Density of the Gas.—For a given temperature, an increase in density of the gas results in a greater heat-flow to the walls.

“The most important practical question connected with the relation between density and heat-loss is the effect of degree of compression on the working and efficiency of gas engines. To put the matter in its simplest

¹ See “Third Report of Gaseous Explosions Committee” of the B. A.

² *Phil. Trans. Roy. Soc., A.*, vol. ccxi. p. 375.

³ “Fifth Report of Gaseous Explosions Committee,” *loc. cit.*

form we may suppose that the engine has a cylindrical combustion space and flat-headed piston, so that the enclosure containing the gas at the moment of firing is a cylinder. The length of this cylinder will in most cases be a fraction of the diameter, the ratio of diameter to length being of the same order as the compression ratio of the engine. The problem, then, is to determine how the amount and distribution of heat-loss to the walls is altered when the compression ratio of the engine is changed, say, by lengthening the connecting rod. In the ordinary case of a fairly high compression ratio, the effect of this alteration will be to reduce the length of the cylindrical combustion space without changing its diameter, and to keep the mass of gas confined therein substantially constant so that the density goes up in inverse proportion to the length of the space. At the same time there will be a small rise in the temperature of the fired mixture consequent on the higher temperature before firing. This, however, would not be very much, amounting to about 100° C. for an increase in compression ratio from 4 to 6.

“The average heat-loss per square foot to the surface will increase, but not in proportion to the density. On the other hand, the area over which that loss is distributed is reduced, but again in a considerably less proportion than the density. For instance, with an engine of equal stroke bore ratio, having a cylindrical combustion chamber, the result of increasing the compression ratio from 4 to 6 will be to reduce the surface of the combustion chamber by nearly 16 per cent. The density is, of course, increased 50 per cent., and if the heat-loss increases in a greater ratio than the square root of the density, which is almost certainly the case, the effect of this increase of compression would be to increase the total heat-loss, and therefore to diminish the efficiency of the engine relative to the air standard. This in the case supposed would not, of course, lead to any reduction in actual efficiency, because the greater heat loss would be more than counterbalanced by the increase in the efficiency due to increased expansion. But it is clear that if the process were carried sufficiently far the absolute efficiency might also be reduced. Some approach to this state of things was found by Burstall when the compression exceeded about 7¹ (Art. 168).

“The conclusion gained from practical experience, that there is a point beyond which it will not pay to increase the compression in the gas engine, is therefore in full accord with the results of laboratory experiments on the relation between density and heat-flow. Not only is there a point beyond which increasing compression is not followed by an increase in efficiency, but before that point is reached the flow of heat per unit area is increased to an amount at which trouble will begin to arise on account of the difficulty of cooling. It is sometimes supposed that the difficulties which arise from pre-ignition when the compression is increased too far are due in some way to the rise of temperature of the gas consequent on the high adiabatic compression. It is very improbable, however, that this has much to do with the matter. The real cause of pre-ignition is the overheating of some part of the interior surface of the metal or of a deposit thereon, due to excessive heat-flow following an increased density. If the metal could be kept clean and cool, compression could be carried to very much higher values than are now used in practice without any danger of

¹ “Third Report of Gas Engine Research Committee,” *Proc. I. Mech. E.*, 1908.

pre-ignition. The effect of increasing density on heat-loss is, however, a matter on which further experimental evidence is needed."

Effect of Turbulence.—During the suction stroke of an engine working on the ordinary four-stroke cycle, or during the charging stroke in the two-stroke cycle, when the charge is admitted into the engine cylinder under pressure from a pump, the mixture of gas and air enters with a high velocity, and the resulting eddying or tubulent motion will persist for some time, so that at the moment of explosion there may be still a good deal of turbulence. In consequence of this motion convection will go on more rapidly and the rate of heat-flow increase. Mr. Dugald Clerk has found that in the compression and expansion of air or CO_2 without fring, the engine being simply motored round, the rate of heat loss at a given

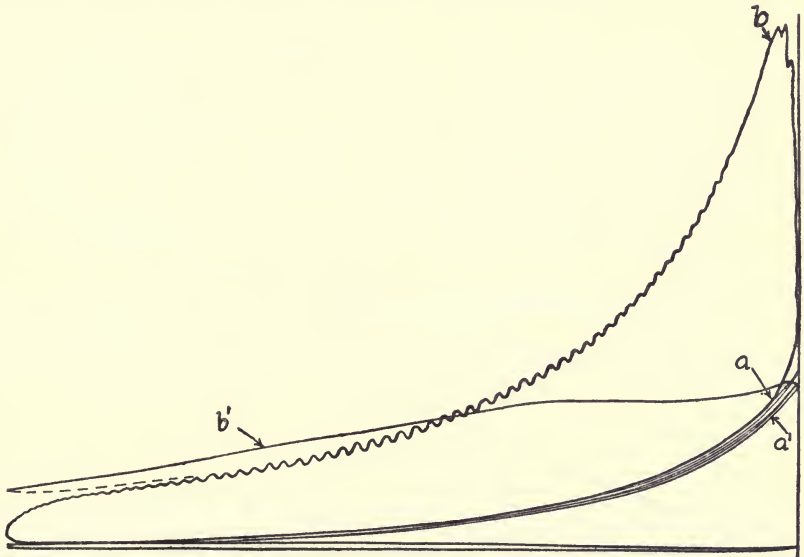

Ordinary ignition a to b takes 0.037 second; trapped ignition on third compression; line a' to b' takes 0.092 second; mixture in both cases 1 volume gas, 9.3 volumes air and other gases.

FIG. 145.

temperature is greater in the first compression after drawing in the charge than in subsequent compressions when the turbulence has died away. Mr. Clerk also found that the result of damping down the turbulence was to retard the rate of combustion of the gas. Figs. 145 and 146, which are reproduced by permission of the Council from the Fifth Report of the Gaseous Explosions Committee of the British Association, show two of his indicator diagrams which were taken with an optical indicator from an engine of 9 inches diameter cylinder and 17 inch stroke running at 180 revolutions per minute. The engine was fitted with two electric igniters; one operating at the charge inlet valve at the back of the combustion chamber and the other operating at the side of the cylinder close to the piston. In Fig. 145 the back ignition was used, and in Fig. 146 the side igniter was in operation. The charge was drawn into the cylinder in the

ordinary way; the valves were then tripped the charge being compressed and expanded for two revolutions before firing.

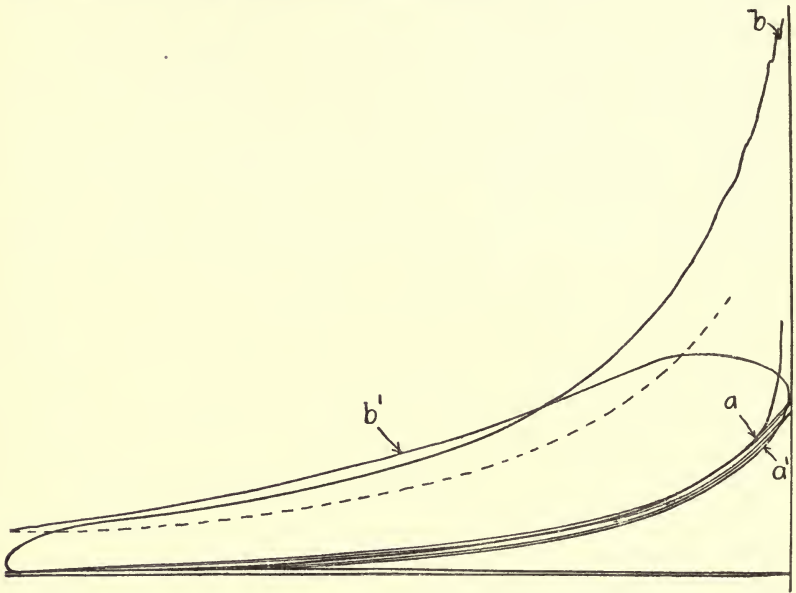

Ordinary ignition a to b takes 0.033 second; trapped ignition on third compression; line a' to b' takes 0.078 second; mixture in both cases 1 volume gas, 9.3 volumes air and other gases.

FIG. 146.

EXAMPLES XIII

1. A gas engine works on the ideal Otto cycle with adiabatic expansion and compression, receiving and rejecting heat at constant volume. The clearance volume is 272 cubic inches, the cylinder is 9.5 inches diameter, and the stroke 19 inches. At the end of the suction stroke the pressure is 13 pounds per square inch absolute, and the temperature of the charge is 100°C . Estimate the ideal "air standard" efficiency, and the temperature and pressure at the end of the compression stroke ($\gamma = 1.4$).

2. Calculate (a) the ideal efficiency of a gas engine working on the Otto cycle when the compression pressure is 135 pounds per square inch above atmospheric, and (b) of an oil engine working on the same cycle with a compression pressure of 65 pounds per square inch above atmospheric. Assume the pressure during the suction stroke to be 14 pounds per square inch absolute in each case, and the expansion and compression to be adiabatic with $\gamma = 1.38$.

3. The engine in Question 1 receives 0.0836 cubic foot of gas per suction stroke at 0°C ., and 14.7 pounds per square inch absolute, the density of the gas being 0.03 pound per cubic foot, and its calorific value 550 B.Th.U. per cubic foot. The strength of the mixture is 1 of gas to 10 of air by volume, and its temperature at the end of the suction stroke is 100°C ., the pressure being 14.7 pounds per square inch absolute. Find

- Weight of the charge drawn in (take weight of 1 cubic foot of air at N.T.P. as 0.0807 pound).
- Pressure and temperature at the end of compression (take $\gamma = 1.38$).
- Rise of temperature during explosion (neglect jacket loss and take $C_v = 0.18$)
- Pressure at the end of the explosion.
- Temperature and pressure at the end of expansion.
- Efficiency of the cycle.

4. The following figures are taken from the expansion curve of a 100 B.H.P. Hornsby-Stockport gas engine indicator diagram having a clearance volume of 0.6035 cubic foot, and piston displacement 3.1528 cubic feet, the volume v representing the total volume of the gases:—

v (cubic foot) .	0.6035	0.7610	0.9188	1.234	1.549	1.865	2.180	2.495	2.810	3.126	3.441
p pounds persquare inch absolute . .	400	279	229	155	121	92	72	60	50	42	35

Estimate the law of the expansion curve.

5. The following data was obtained from a gas engine indicator diagram. Cylinder volume including clearance = 0.54 cubic foot. Atmospheric pressure 15 pounds per square inch absolute ; temperature at beginning of compression stroke 150° F. ; pressure at beginning of compression stroke 15 pounds per square inch absolute ; law of expansion curve $pv^{1.57} = \text{constant}$. At a point A on the expansion curve the pressure was 245 pounds per square inch absolute, and volume 0.127 cubic foot. At another point B on the curve the pressure was 40 pounds per square inch absolute and volume 0.505 cubic foot. Estimate the temperature at A and B, and find the heat given to or taken from the gases between these two points. (Assume $\gamma = 1.39$.)

CHAPTER XIV

THEORY OF THE INTERNAL COMBUSTION ENGINE ASSUMING THE SPECIFIC HEAT A LINEAR FUNCTION OF THE TEMPERATURE

184. Explosion at Constant Volume.—If a combustible mixture of gas and air be ignited in a closed vessel, the temperature and pressure of the mixture will rapidly rise, it being possible to calculate their values if certain assumptions are made. Assuming no loss of heat to take place from the vessel and that the specific heat of the gases remains constant, if H represents the number of units of heat evolved during the combustion, W the total weight of the contents of the vessel, and C_v their specific heat at constant volume, then—

$$H = C_v \times W \times (T_1 - T_2)$$

where T_1 and T_2 denote the absolute temperatures after and before combustion respectively.

The only unknown in this equation is T_1 , the absolute temperature reached as a result of combustion. Assuming further that $p v = RT$, the resulting absolute pressure (p) may also be calculated when T is known. It is found that the maximum pressure calculated in this way is always very much greater than the actual pressure observed during experiments; in most cases the calculated pressure is about *twice* as high as the actual pressure observed. Several explanations have been offered from time to time to explain this discrepancy, the chief of which are:—

1. *The Dissociation Theory.*—It is well known that when definite chemical compounds such as CO_2 and H_2O are heated to a high enough temperature, they are reduced to simple gases, and in so doing absorb heat. Bunsen thought that this dissociation or decomposition by heat at very high temperatures accompanied by the absorption of heat, reduced the temperature attained by the combustion of an explosive mixture. Accepting this theory one would expect that the higher the temperature reached with rich mixtures the greater would be the loss of pressure, and that with weak mixtures when lower temperatures and pressures are obtained, the less would be this loss. Examination of the results of experiments, however, show that this is not so, the loss of pressure being practically the same with rich as with weaker mixtures. Evidently, then, this theory does not of itself account for what happens.

2. *Cooling Theory.*—This theory assumes that during combustion a

temperature is soon reached above which heat is conducted away by the metal walls more rapidly than is generated by combustion, with the result that the greatest pressure reached is far less than it would be if no heat were lost. If this were the sole explanation, the loss of pressure would not be constant but would vary with the size and shape of the vessel in which combustion takes place, and this is not found to be the case.

3. *Increasing Specific Heat Theory.*—Mallard and Le Chateleur concluded from the results of their experiments that the reduction of the explosion pressure and temperature might be produced by the continued increase of specific heat of the gases at very high temperatures. The objection to this theory as the sole explanation is the same as that to the dissociation theory already mentioned.

In 1906¹ Dugald Clerk carried out a series of experiments in a gas engine cylinder, and came to the conclusion that the apparent specific heat of the working fluid of the internal combustion engine (consisting chiefly of a mixture of N_2 , CO_2 , H_2O , and O_2), when calculated from the first $\frac{3}{10}$ of the stroke, undoubtedly increases between the observed temperatures $300^\circ C.$ and $1500^\circ C.$, but tends towards a limiting value at $1500^\circ C.$; and further, that the apparent change in specific heat is not entirely due to a real change in specific heat, but requires in addition, continuing combustion after the maximum pressure is reached, *i.e.* after burning, to account for all the facts.

4. *After-Burning Theory.*—As mentioned above, Dugald Clerk suggested that combustion was not instantaneous, and that it continued long after the maximum pressure was reached. In a gas engine this would mean that combustion continued right through the working stroke, and that unburnt gas would pass away in the exhaust. Experiment has not proved conclusively that this is so, and it is unusual to find in a good engine more than a very small percentage of unburnt gas in the exhaust.

Professor Hopkinson² came to the conclusion that even in the weakest mixtures, combustion, when once initiated at any point, is almost instantaneously complete, and that the specific heat of the products is very much greater at high than at low temperatures.

The discrepancy is doubtless due not merely to any one of the above four theories, but to all of them acting together.

185. Internal Energy of Gases at High Temperatures.³—The physical properties of a gas in chemical equilibrium are completely specified when we know—

(1) The relation between the pressure and volume at constant temperature.

(2) The internal energy per unit volume as a function of the temperature and the density.

The internal energy of a gas per unit of mass is usually defined as $C_v(T - T_0)$ (Chap. I., Art. 6) where T_0 is some standard temperature from which energies are reckoned, and C_v the mean specific heat at constant volume between T and T_0 . In all the cases met with in gas engine practice the first of the above relations is, for all practical purposes,

¹ *Trans. Roy. Soc.*

² *Trans. Roy. Soc.*, 1906.

³ From the "First Report of the Gaseous Explosion Committee of the British Association."

given by Boyle's Law, viz. $p v = \text{constant}$.² It is usual also to make the further assumption that the product $p v$ is proportional to the absolute temperature, *i.e.* $p v = RT$ (Art. 4). If this latter assumption is true, then the internal energy is a function of the temperature only (Art. 6); if it is not true, then the relation between p , v , and T must be obtained from a knowledge of the internal energy, which will be a function of both temperature and density. So far as the present state of knowledge goes, the energy is to be expressed in terms of the absolute temperature only; but an important part of future investigation must deal with its dependence on the density, either by direct measurement or by a determination of the relation between p , v , and T at high temperatures.

The prediction of the temperature reached in combustion rests upon a knowledge of the energy function. For, subject to corrections for loss of heat, incomplete combustion, and work done while combustion proceeds, the thermal energy of the mixture of steam (H_2O), CO_2 , etc., after combustion is equal to the chemical energy of the gases from which that mixture was formed. The chemical energy can be accurately inferred from the composition of the combustible gases, and, the thermal energy being thus known, the temperature can be calculated from a table of the energy function. The pressure or volume changes resulting from the combustion can be deduced from the temperature by the use of the p , v , T , relations, which again depend upon the energy function. A table of this function, *i.e.* the internal energy at high temperature, is therefore of very great importance.

In order to predict the performance of a gas engine we must know the rise of temperature and pressure produced by the explosion. This is not only the principal factor in the mean pressure developed, it also determines in large measure the mechanical design of the engine and the necessary strength of its parts. In proceeding further to analyse the indicator diagram given by the engine with the object of accounting at each point for the heat which has been put in, a knowledge of this function is again required. The heat accounted for on the diagram is the work which has been done, *plus* the heat contained in the gas. The latter item can be calculated from the temperature, if the energy function be known. The balance unaccounted for, which it is usually the object of such investigations to find—whether in the steam or the gas engine—is the heat which has been lost to the walls or has been suppressed owing to incomplete combustion. In fact, the internal energy of the gases at high temperatures plays much the same part in the analysis of gas-engine phenomena as does the total heat of steam in investigating the working of the steam engine.

From a table of internal energy it is possible to construct an ideal indicator diagram corresponding to the cycle of operations in use for any given combustible mixture on the assumption that the combustion is instantaneous and complete at the in-centre; that there is no loss of heat in compression, explosion, or expansion; and that during expansion the gases are at all times in thermal and chemical equilibrium. These conditions can never be completely realised in practice, but can in theory be approached asymptotically by improvements in design carried on

¹ See Witkowski, *Phil. Mag.*, vol. xli. (1896), p. 309.

within certain defined limits—namely, that the degree of compression and the nature of the mixture are to be unaltered. For example, the heat loss may be reduced by increasing the size of the engine and altering the nature of the cylinder walls, and the attainment of thermal and chemical equilibrium may be promoted by reducing the speed. Such an ideal cycle is, in fact, precisely analogous to the Rankine cycle of the steam engine, in that it takes account of the actual physical properties of the working substance, but leaves out of account such non-essential imperfections as heat loss due to the cylinder walls. It represents an ideal which the real engine may approach indefinitely but can never attain; and the closeness of the approach is a true measure of the perfection of the engine.

The ideal cycle which has hitherto been used in discussing the performance of gas engines is the well-known "air cycle" (Art. 163). This is based upon a special assumption as to the form of the energy functions—namely, that it is a linear function at high, as it is known to be at low, temperatures. The specific heat of the working substance is taken to be constant and equal to 19 foot-pounds per cubic foot, or 4·8 calories per gramme molecule (see Introduction, p. xii). Recent researches, however, on the properties of gases at high temperatures have definitely shown that the assumption of constant specific heat is erroneous, and have given sufficient information about the magnitude of the error to show that it is of material importance. They have shown that the air cycle cannot be regarded as equivalent to the Rankine cycle in the steam engine, inasmuch as it does not take account of the properties of the actual working fluid, but postulates hypothetical fluid which has no real existence. It is as though in the theory of the steam engine the total heat of the steam were to be taken as equal to its latent heat, the sensible heat of the water being neglected. This assumption would lead to a simpler formula for the ideal efficiency for the steam engine, but would be erroneous in the same way and to about the same extent as the air cycle formula for the gas engine. If the sensible heat of the steam could be neglected, the Rankine

cycle efficiency $\frac{(T_1 - T_2)\left(1 + \frac{L_1}{T_1}\right) - T_2 \log_e \frac{T_1}{T_2}}{L_1 + T_1 - T_2}$ (Art. 55) would reduce

to the Carnot cycle efficiency $\frac{T_1 - T_2}{T_1}$, for no heat would then be necessary

to warm the water from the condenser to the boiler temperature and the whole process would become reversible. The closer approximation to the real cycle which is made by taking account of the actual properties of the working fluid—in the steam engine, the total heat of the steam instead of only the latent heat, in the gas engine, the true value of the energy instead of that based upon the assumption of constant specific heat—though it leads to some complication of formulæ, gives compensating advantages of real practical value. It shows the engineer what are the limits to the improvements which can be effected by changes in design or increase in size, and it enables him to judge whether it is better that the lines of development should proceed in such directions or in the direction of radically modifying the cycle of operations.

186. Measurement of the Internal Energy or Specific Heats

heat between 0° and 200° C., is between 7.45 and 7.55, and that its rate of increase with temperature is between 0.009 and 0.013, or, roughly, one six-hundredth part per $^{\circ}$ C.

For the volumetric heat of CO_2 the Explosions Committee consider Swann's values to be correct to within 1 per cent. They are as follows¹:—

	At 20° C.	At 100° C.
Specific heat at constant pressure (C_p) . . .	0.202	0.221
Volumetric heat—		
Calories per gramme molecule (taken as 41		
grammes)	6.93	7.76
Foot-pounds per cubic foot	27.4	30.7

Holborn and Austin carried the constant-pressure experiments for air and CO_2 up to 800° C.² The gas was heated electrically and the temperature measured with a thermo-couple. Similar measurements on steam were made by Holborn and Henning, who subsequently carried the determinations for the three gases up to 1400° C.³ The following table shows the volumetric heats (C_v) of air, steam, and CO_2 at 100° , 600° , and 1100° C. respectively. The values at 100° C. are derived from the experiments of Wiedemann and Regnault; those at 600° and 1100° C. are based on the specific heat values given by Holborn and Henning. The corresponding values of γ are also shown ($\gamma = 1 + \frac{1.98}{C_v}$).

	100° C.		600° C.		1100° C.	
	C_v	γ	C_v	γ	C_v	γ
Air	4.9	1.404	5.2	1.38	5.75	1.345
Steam . . .	6.6	1.30	6.85	1.29	8.50	1.24
CO_2 . . .	7.5	1.26	9.95	1.20	11.10	1.18

These figures show that the volumetric heat of air increases by about 0.0009, that of steam by 0.0033, and that of CO_2 by 0.0036 per $^{\circ}$ C. over the range 100° to 1100° C. There is no evidence that the rate of increase is other than constant in the case of air; but there can be no doubt that the average rate of increase between 100° and 1100° C. in CO_2 is less than half the rate of increase between 0° and 200° C. as determined by Regnault and Wiedemann. There is also distinct evidence in these and in other experiments that the rate of increase of the specific heat of steam becomes greater as the temperature rises.

Holborn and Henning give the mean value of C_p between 0° and t° C. for nitrogen and carbon dioxide as—

¹ *Ibid.*

² Wiss, "Abhandlungen der Phys. Techn. Reichsanstalt," 1905.

³ *Ann. de Phys.*, 23, 1907, p. 809.

N_2 , $C = 0.2350 + 0.000019t$ (a straight line).

CO_2 , $C_p^p = 0.2010 + 0.0000742t - 0.00000018t^2$ (a slightly curved line).

(2) *Constant-volume Experiments.*—Extensive researches were carried out by Mallard and Le Chatelier and by Langen. The former experimenters used a cylindrical vessel 17 cm. \times 17 cm., whereas Langen used a sphere 40 cm. diameter. The ratio $\frac{\text{surface}}{\text{volume}}$ was 2.3 times as great in the first as in the second case.

The temperatures reached in these explosion experiments vary from 1300 to 3000° C. Temperatures below 1500° C. are, however, obtained by the use of weak mixtures, involving slow burning and large cooling corrections, and but little reliance can be placed on the results. Langen made very few observations on mixtures giving lower temperatures than 1500° C., and takes that as the lower limit of the range of temperature to which his observations apply. The temperature 3000° C. is about that reached in the explosion of hydrogen and oxygen in their combining proportions. This is much above the mean temperature ordinarily reached in the gas engine, the upper limit of which may be put at about 2000° C., although 2500° C. or more is occasionally reached locally. The formulæ given by Langen as representing the results of his observations are—

Air, $C = 4.8 + 0.0006t$ calories per gramme molecule.
 CO_2 , $C = 6.7 + 0.00260t$ „ „ „
 H_2O , $C = 5.9 + 0.00215t$ „ „ „

where C is the mean thermal capacity over the range 0° to t° C.

Mallard and Le Chatelier, in 1887, published the following results :—

For CO_2 $C_v = 0.1477 + 0.000176t$
 H_2O $C_v = 0.3211 + 0.000219t$
 N_2 $C_v = 0.170 + 0.0000872t$
 O_2 $C_v = 0.1488 + 0.0000763t$

The following table shows the internal energy of various gases. The energy at 800° C. and 1200° C. are based on Holborn and Henning's results, and Clerk's results are given for comparison. The results for the gas-engine mixture are plotted in Fig. 147, on which points obtained by Mallard and Le Chatelier's formula are also shown.

	800° C.		1200° C.		1600° C.	2000° C.
	Clerk.	Holborn and Henning.	Clerk.	Holborn and Henning.	Langen.	Langen.
Air	—	3570	—	5,840	8,700	11,500
CO_2	—	6460	—	10,880	17,000	23,300
H_2O	—	4670	—	7,930	14,400	19,900
Gas-engine mixture .	4250	3840	6900	6,340	9,800	13,200
Ideal gas ($C = 4.9$). .	3430		5400		7,350	9,300

To convert the above values to foot-pounds per cubic foot multiply by 3.96. The results in these units are shown plotted in Fig. 148.

(3) *Clerk's Experiments*.¹—These cover about the same range of temperature as those of Holborn and Henning. The gas used was the product of an explosion in a gas engine, and therefore consisted of a mixture of CO₂, steam, and air. It was first expanded in the ordinary course after the explosion, and was then heated by compression on the next in-stroke of the engine, the valves being kept closed for this purpose. On the next out-stroke the gas was again expanded, then compressed

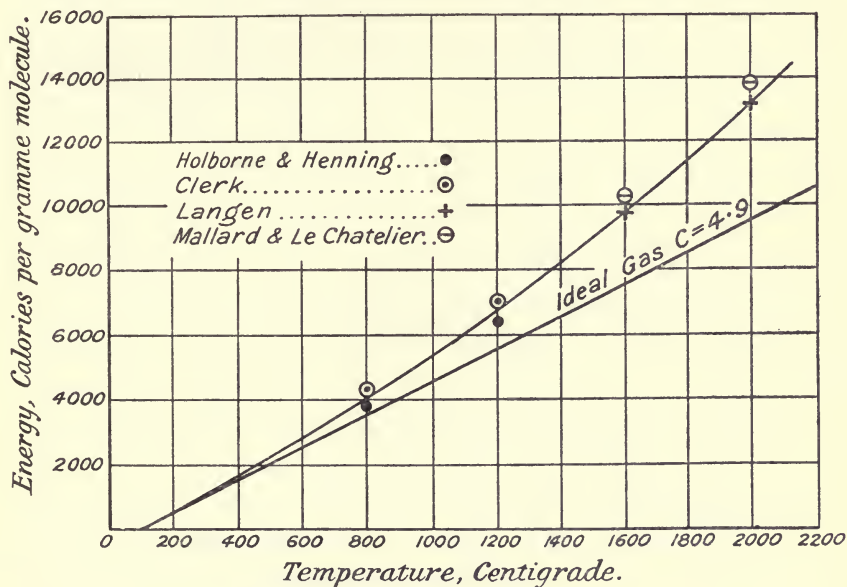

FIG. 147.

again, and so on, the valves remaining closed and the engine running on its own momentum. An indicator diagram was taken of the whole operation. The change of internal energy in any portion of a compression stroke, e.g. BC in Fig. 149, is equal to the work done less the heat lost to the cylinder walls; in an expansion stroke (CD) it is the work done plus the heat lost. The loss of heat comes in as a correction on the work done and was estimated by a comparison of the compression line and the expansion line immediately following (CD). The calculation is based on the assumption that the total heat loss from the hot gases during any portion of a stroke is the same in expansion and compression if the mean temperature be the same.

In the first compression the temperature of the gas rose to about 1100° C. (at the point C, Fig. 149), during the first three-tenths of the following expansion stroke (CD), the temperature fell to about 700° C. The work done in this part of the expansion was measured and the heat

¹ *Proc. Roy. Soc., A.*, vol. lxxvii.

loss determined as above was added. Thus the change of internal energy corresponding to the temperature change 1100° to 700° C. was obtained.

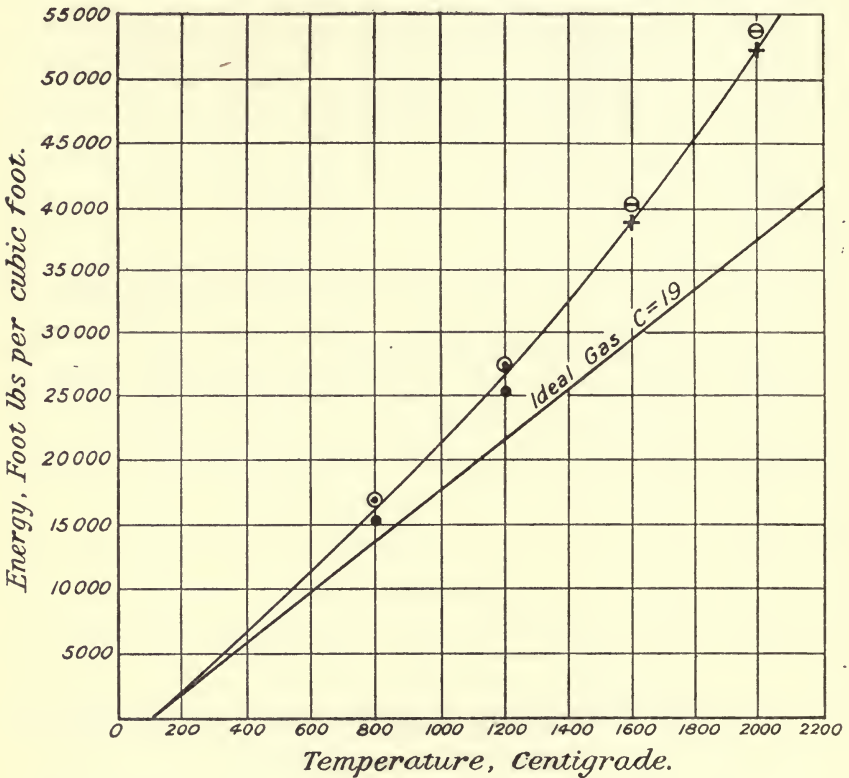

FIG. 148.

The average volumetric heat over this range is, within the errors of experiment, equal to the volumetric heat at the mean temperature 900° C., which is by this method determined directly

instead of by difference, as is necessarily the case when (as in Holborn and Henning's experiments) the whole internal energy associated with complete cooling of the gas is measured. The following table shows the internal energy of the mixed gas with which Clerk experimented, calculated from Holborn and Henning's figures, together with the energy calculated from Clerk's

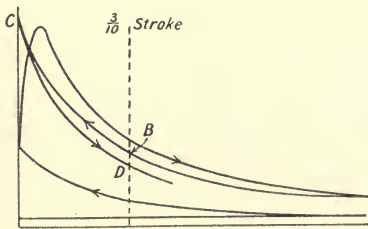

FIG. 149.

values for the mean volumetric heat. The energies are reckoned from 100° C. and the energies of an ideal gas with constant volumetric heat 4.9 are added for comparison.

Temperature ° C.	Holborn and Henning.	Clerk.	Ideal gas.
400	1580	1720	1470
800	3840	4300	3430
1200	6285	7040	5390

It will be seen that Clerk's values are about 10 per cent. higher than the others. Corrections resulting from further experiments show that Clerk's values given above are about 3 per cent. too high.¹

The Probable Value of C_v for a Gas Engine Mixture.—For a mixture of 1 of gas to 9 of air, Burstall gives

$$C_v = 0.178 + 0.105 \frac{t}{1000}$$

From the straight part of Clerk's curve—

$$C_v = 0.194 + 0.051 \frac{t}{1000}$$

187. Rate of Heat Reception with Variable Specific Heats.

Now, $\delta H = C_v \delta T + p \delta v$ (Art. 10)
 $\therefore \frac{dH}{dv} = C_v \frac{dT}{dv} + p \dots \dots \dots (1)$

But $\frac{dT}{dv} = \frac{1}{R} \left(p + v \frac{dp}{dv} \right)$ (equation (1), Art. 14)
 $\therefore \frac{dH}{dv} = \frac{C_v}{R} \left(p + v \frac{dp}{dv} \right) + p \dots \dots \dots (2)$

which is the same as equation (3), Art. 14.

Now, let $C_p = \alpha_1 + kt$, and $C_v = \beta_1 + kt$

Then $R = C_p - C_v = \alpha_1 - \beta_1$

and when $t = 0^\circ \text{C.} \cdot \frac{C_p}{C_v} = \gamma_0 = \frac{\alpha_1}{\beta_1}$

Substituting for C_v and R in (2), we have

$$\begin{aligned} \frac{dH}{dv} &= \frac{\beta_1 + kt}{\alpha_1 - \beta_1} \left(p + v \frac{dp}{dv} \right) + p \\ &= p \left(1 + \frac{\beta_1 + kt}{\alpha_1 - \beta_1} \right) + \frac{\beta_1 + kt}{\alpha_1 - \beta_1} \cdot v \frac{dp}{dv} \\ &= \frac{1}{\alpha_1 - \beta_1} \left\{ p \alpha_1 - p \beta_1 + p \beta_1 + p kt + \beta_1 v \frac{dp}{dv} + kt v \frac{dp}{dv} \right\} \dots (3) \\ &= \frac{1}{\beta_1 - \alpha_1} \left\{ p \cdot \frac{\alpha_1}{\beta_1} + v \frac{dp}{dv} + \frac{p kt}{\beta_1} + \frac{kt v}{\beta_1} \cdot \frac{dp}{dv} \right\} \end{aligned}$$

$$\therefore \frac{dH}{dv} = \frac{1}{\gamma_0 - 1} \left\{ p \cdot \gamma_0 + v \frac{dp}{dv} \right\} + \frac{kt}{\alpha - \beta} \left\{ p + v \frac{dp}{dv} \right\} \dots \dots (4)$$

¹ "Second Report of Gaseous Explosions Committee," Section G, Winnipeg, 1909, p. 5.

If the specific heats were constant, *i.e.* if $k = 0$, the above equation reduces to $\frac{dH}{dv} = \frac{1}{\gamma_0 - 1} \left\{ p\gamma_0 + v \frac{dp}{dv} \right\}$, the same as (3), Art. 14.

If the specific heats be expressed in terms of the absolute temperature, *i.e.* writing $C_p = \alpha + kT$ and $C_v = \beta + kT$, $R = \alpha - \beta$.

This may be written—

$$\frac{dH}{dv} = \frac{1}{\alpha - \beta} \left\{ p\alpha + pkT + \beta v \frac{dp}{dv} + kTv \frac{dp}{dv} \right\} \dots (5)$$

Rate of heat reception when the expansion or compression follows the law $pv^m = \text{constant}$.

Let $pv^m = c$, say,

then, as in Art. 14, $v \cdot \frac{dp}{dv} = -np$

Substituting this in (3) gives

$$\begin{aligned} \frac{dH}{dv} &= \frac{1}{\gamma_0 - 1} \{ p \cdot \gamma_0 - np \} + \frac{kt}{\alpha - \beta} \{ p - np \} \\ &= \frac{\gamma_0 - n}{\gamma_0 - 1} \cdot p + \frac{kt}{\alpha - \beta} \{ p - np \} \\ &= \left\{ \frac{\gamma_0 - n}{\gamma_0 - 1} - kt \cdot \frac{n - 1}{\alpha - \beta} \right\} p \dots (6) \end{aligned}$$

If the specific heats were constant, *i.e.* if $k = 0$, this reduces to

$$\frac{dH}{dv} = \frac{\gamma_0 - n}{\gamma_0 - 1} \cdot p, \text{ the same as (4), Art. 14.}$$

188. Adiabatic Expansion with Variable Specific Heats.—

For an adiabatic expansion $\frac{dH}{dv} = 0$, hence from (5), Art. 187,

$$p\alpha + pkT + \beta v \frac{dp}{dv} + kTv \frac{dp}{dv} = 0 \dots (7)$$

$$\therefore v \frac{dp}{dv} (\beta + kT) + p\alpha + pkT = 0$$

Dividing by pv we get

$$\frac{dp}{P} (\beta + kT) + \frac{dv}{v} (\alpha + kT) = 0$$

Now,

$$T = \frac{pv}{R}$$

$$\therefore \frac{dp}{P} \left(\beta + k \cdot \frac{pv}{R} \right) + \frac{dv}{v} \left(\alpha + k \cdot \frac{pv}{R} \right) = 0$$

$$\beta \cdot \frac{dp}{P} + \alpha \frac{dv}{v} + \frac{kv}{R} \cdot dp + \frac{kp}{R} dv = 0$$

or

$$\beta \cdot \frac{dp}{P} + \alpha \frac{dv}{v} + \frac{k}{R} d(pv) = 0$$

Integrating, we get

$$\beta \log p + \alpha \log v + \frac{k}{R}(pv) = \text{constant} \dots (8)$$

or
$$\beta \log p + \alpha \log v + kT = \text{constant} \dots (9)$$

Hence the adiabatic equation may be written

$$p^\beta v^\alpha e^{\frac{k \cdot pv}{R}} = \text{constant} \dots (10)$$

or
$$p^\beta v^\alpha e^{kT} = \text{constant} \dots (11)$$

189. Reduction of Efficiency when the Working Fluid is changed for one having a Higher Specific Heat.—Assuming the specific heat to remain constant, the efficiency will be given by

$$E = 1 - \left(\frac{1}{r}\right)^{\gamma-1} \quad \text{where } \gamma = \frac{C_p}{C_v}$$

Now since

$$C_p - C_v = R$$

$$\gamma - 1 = \frac{R}{C_v} \quad (\text{equation (2), Art. 7})$$

$$\therefore E = 1 - \left(\frac{1}{r}\right)^{\frac{R}{C_v}} \quad \text{or } 1 - E = \left(\frac{1}{r}\right)^{\frac{R}{C_v}} \quad \text{or } \frac{1}{1 - E} = (r)^{\frac{R}{C_v}}$$

Differentiating with respect to C_v , we have

$$\frac{1}{1 - E} = (r)^{\frac{R}{C_v}}$$

$$\therefore -\frac{1}{1 - E} \cdot \frac{dE}{dC_v} = \frac{R}{C_v^2} \cdot \log_e r$$

$$\therefore \frac{dE}{dC_v} = -\frac{R(1 - E)}{C_v^2} \cdot \log_e r \dots (1)$$

Or since

$$1 - E = \left(\frac{1}{r}\right)^{\frac{R}{C_v}}$$

$$\frac{dE}{dC_v} = -\frac{R}{C_v^2} \cdot \left(\frac{1}{r}\right)^{\frac{R}{C_v}} \cdot \log_e r \dots (2)$$

(1) may also be written

$$dE = -\frac{dC_v}{C_v^2} \{R(1 - E) \cdot \log_e r\}$$

$$i.e. \frac{dE}{E} = -\frac{dC_v}{C_v} \left\{ \frac{R}{C_v} \cdot \frac{1 - E}{E} \log_e r \right\} = -\frac{dC_v}{C_v} \left\{ (\gamma - 1) \frac{1 - E}{E} \log_e r \right\} \quad (3)$$

EXAMPLE 1.—Find the fractional change of efficiency, assuming $\gamma = 1.40$ and $r = 5.96$, corresponding to a 1 per cent. increase in C_v .

In this case $E = 1 - \left(\frac{1}{5.96}\right)^{0.4} = 0.499$

$$\therefore \frac{dE}{E} = -\frac{1}{100} \left\{ 0.4 \times \frac{1 - 0.499}{0.499} \times 2.303 \log_{10} 5.96 \right\}$$

$$= -\frac{1}{100} \left\{ \frac{0.4 \times 0.501}{0.499} \times 2.303 \times 0.7752 \right\}$$

$$= -\frac{1}{100} \{ 0.717 \}$$

$$= -0.717 \text{ per cent.}$$

i.e. the efficiency would decrease 0.717 per cent. as the result of C_v increasing 1 per cent.

190. Calculation of the Ideal Efficiency of a Gas Engine assuming that the Specific Heat is a Linear Function of the Temperature.—The method will be best illustrated by means of an example. We will take the case of an engine working on the ordinary Otto cycle with “hit and miss” governing, rated to give 40 B.H.P. at a speed of 180 revolutions per minute. The following are particulars of the engine¹:—

- Cylinder diameter 11½ inches
- Stroke 21 inches
- Compression space 407 cubic inches
- Compression ratio 6.37 inches

Cambridge coal gas was used throughout as a fuel. The following table gives its average compositions:—

	Percentage by volume.	O required for combustion.	Steam produced.	CO ₂ produced.
H	47.2	23.6	47.2	—
CH ₄	35.2	70.4	70.4	35.2
Heavy hydrocarbons	4.8	22.6	16.0	14.4
CO	7.15	3.6	—	7.15
N	5.4	—	—	—
Other gases	0.25	—	—	—
	100.00	120.2	133.6	56.75

The higher calorific value varies between 630 and 680 B.Th.U. per standard cubic foot, the lower value between 570 and 620.

From anemometer-experiments it is found that, with a medium jacket temperature and with the engine exploding every time, the volume of mixed gas and air taken in is 0.85 of the stroke volume. If we assume a normal barometer (14.7 pounds per square inch absolute) and an outside tem-

¹ The information in this article is taken by kind permission from Professor Hopkinson's paper on the “Thermal Efficiency of Gas Engines,” *Proc. Inst. Mech. Eng.*, April, 1908.

perature of 15° C., the *quantity* taken in (reckoned in standard cubic feet) is $0.85 \times \frac{273}{288} = 0.805$ of the stroke volume.

This is mixed with the contents of the compression space and possibly also with some of the exhaust products which have backed in from the exhaust pipe. The volume of the compression space is 0.187 of the stroke volume; the pressure of the gases is atmospheric and their temperature may be taken as that resulting from the nearly adiabatic expansion which took place at release. The release pressure is between 50 and 55 pounds per square inch absolute according to the strength of the mixture. We may assume 52 pounds. The volume at release is 0.90 times the total cylinder volume.

Assuming that the suction temperature was 100° C., or 373° absolute, we may find the temperature (T) just before release, using the relation

$$\frac{p_1 v_1}{T_1} = \frac{p_2 v_2}{T_2}$$

$$i.e. \frac{(52 \times 144) \times 0.90}{T} = \frac{(14.7 \times 144) \times 1}{373}$$

$$\therefore T = 1190^{\circ} \text{ absolute}$$

The expansion down to atmospheric pressure, which occurs very rapidly after release, reduces this temperature to

$$1190 \times \left(\frac{14.7}{52}\right)^{\frac{1.35-1}{1.35}} \text{ assuming } \gamma = 1.35$$

$$= 1190 \times \left(\frac{14.7}{52}\right)^{0.26}$$

$$= 860^{\circ} \text{ absolute, or say } 600^{\circ} \text{ C.}$$

Assuming that this temperature does not change materially during the exhaust stroke, it follows that the contents of the compression space amount to

$$0.187 \times \frac{273}{860} = 0.06 \text{ of the stroke volume, reckoned in standard cubic feet.}$$

The total cylinder contents at the end of the suction stroke would therefore, at standard temperature and pressure, occupy

$$0.805 + 0.06 = 0.865 \text{ of the stroke volume}$$

In what follows it is assumed that the gas has a calorific value of 600 B.Th.U. per standard cubic foot, the products of combustion being cooled to a temperature of 100° C. At the end of the suction stroke the valves are all closed and the cylinder is then full of the mixture of coal-gas and air (assumed to be dry) which has been drawn in *plus* products of the previous explosion amounting to 7 per cent. of the whole, the temperature being 100° C. and the pressure 14.7 pounds per square inch absolute. The mixture is compressed adiabatically and is fired at the in-centre, the combustion being complete and instantaneous. The products of the combustion are then expanded without loss of heat to the out-centre,

when the exhaust-valve is opened. The efficiency is calculated for two mixtures, of which the following are particulars :—

	A	B
Volume of coal-gas taken per suction (cubic feet at external temperature and pressure)	0·1	0·13
Percentage of coal-gas in mixture drawn in	9·4	12·2
Percentage of coal-gas in mixture in engine	8·8	11·4
<i>Products of combustion of 1 cubic foot of the mixture.</i>		
	A	B
Steam	0·125	0·163
CO ₂	0·053	0·069
N and O	0·793	0·732
Total	0·971	0·964

The above analysis of the products of combustion is calculated from the average composition of the coal-gas.

The internal energy curves (Fig. 150) have been calculated from these compositions, using the following values for specific heats :—

Temperature.	800° C.	1400° C.	1900° C.
Air	19·9	22·0	23·5
H ₂ O	26·0	31·0	39·6
CO ₂	35·2	41·4	46·1

The figures are the mean values of the specific heats at constant volume up to the temperature in question expressed in foot-pounds per standard cubic foot of the gas. Those at 800° and 1400° are the results of Holborn and Austin¹ and of Holborn and Henning² obtained by external heating at constant pressure. These are probably correct within 3 per cent. The figures at 1900° are from Langen's explosion experiments;³ they are probably rather too high because of incomplete combustion and loss of heat, but they are the best available. The values are those given by Clerk⁴ for mixed gases; they are rather higher than those calculated from the above figures at 800° and 1400°.

It is most convenient to follow what happens to a standard cubic foot of the mixture in passing through the engine. The mixture contains $\frac{0·805}{0·865} = 0·93$ of its volume of gas and air, the rest being products of combustion. Starting at 100° C. or 373° absolute it is compressed adiabatically 6·37 times.

The temperature after compression is $373 \times (6·37)^{0·4} = 780°$ absolute.

Rise in temperature during compression = $780 - 373 = 407°$ C.

Work done during compression = $19 \times 407 = 7700$ foot-pounds,

¹ *Researches of the Reichsanstalt*, vol. iv., 1905.

² *Annalen der Physik*, vol. xxxiii., 1907.

³ *Zeitschrift des Vereines Deutsches Ingenieure*, vol. xlvii., 1903.

⁴ "On the Limits of Thermal Efficiency in Internal Combustion Motors," *Proc. Inst. Civ. Eng.*, vol. 169, p. 121.

since the thermal capacity is constant and equal to 19 foot-pounds per cubic foot. This is the internal energy at the end of compression with either mixture.

The pressure at the end of compression is—

$$14.7 \times (6.37)^{1.4} = 196 \text{ pounds per square inch absolute}$$

I. Strong Mixture (B).—In this case 12.2 per cent. of the mixture drawn in is coal-gas. In the mixture as it exists in the engine (after mixing with the products of the previous explosion) the percentage of coal-gas is

$$12.2 \times 0.93 = 11.4 \text{ per cent.}$$

The heating value of the gas per standard cubic foot is therefore

$$0.114 \times 600 \times 778 = 53,000 \text{ foot-pounds}$$

$$\text{Add to this the work of compression} = \underline{7,700 \text{ foot-pounds}}$$

$$\text{Internal energy after explosion} = 60,700 \text{ foot-pounds}$$

After explosion the standard cubic foot of mixture becomes 0.964 cubic foot of products.

∴ internal energy per cubic foot of products reckoned from 100° C. is

$$\frac{60,700}{0.964} = 63,000 \text{ foot-pounds}$$

From the curve (Fig. 150) the corresponding temperature is

$$2210^\circ \text{ C. or } 2480^\circ \text{ absolute}$$

and the pressure is $0.964 \times \frac{2480}{780} \times 196 = 600$ pounds per square inch absolute.

The expansion curve is computed by trial and error. We assume an expansion curve of the form $p v^n = \text{constant}$. The true adiabatic will not be of this form because the specific heat is not constant (Art. 188). But if n be so chosen that no heat is lost on the whole during expansion, the loss in the first portion being balanced by an equal gain in the second, we shall have a sufficiently close approximation to the real adiabatic. If we take $n = 1.20$ the temperature at the end of expansion is

$$\frac{2480}{(6.37)^{0.20}} = 1713^\circ \text{ absolute, or } 1440^\circ \text{ C.}$$

From the curve (Fig. 150) the internal energy at this temperature is read off to be 33,700 foot-pounds, and the loss of energy in expansion is therefore

$$63,000 - 33,700 = 29,300 \text{ foot-pounds}$$

The work area under this curve is most simply computed by noting that it is the adiabatic of a gas for which γ is constant and equal to 1.20, and for which the specific heat is therefore

$$\frac{R}{\gamma - 1} \text{ foot-pounds per pound ((2), Art. 7)}$$

$$= \frac{53.2 \times 1.8}{1.2 - 1} \times 0.0807 \text{ (since 1 standard cubic foot of air weighs } 0.0807 \text{ lb.)}$$

$$= 38.7 \text{ foot-pounds per standard cubic foot.}$$

The fall of temperature during expansion is $2480 - 1713 = 767^\circ \text{C}$.

\therefore work done during expansion = $38.7 \times 767 = 29,700$ foot-pounds per standard cubic foot of products.

This work done is slightly more than the loss of energy (29,300 foot-pounds), showing that along this assumed expansion line there must be some gain of heat on the whole. If the index 1.21 be tried, corresponding to an average specific heat of 36.9 foot-pounds per standard cubic foot,

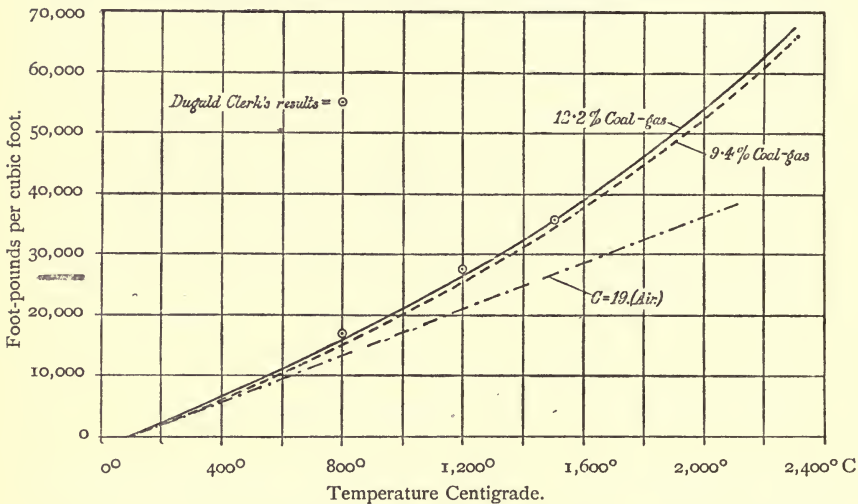

FIG. 150.—Internal energy curves.

it will be found that the loss of energy in expansion is 30,500 foot-pounds, and the work done 29,500 foot-pounds, corresponding to a slight loss of heat in expansion. We may take the index 1.20 as sufficiently near. Since there is only 0.964 cubic foot of products for every cubic foot of original mixture, the work done in expansion per cubic foot of mixture is

$$29,700 \times 0.964 = 28,600 \text{ foot-pounds}$$

The net work done in the cycle after deducting the work of compression is

$$28,600 - 7700 = 20,900 \text{ foot-pounds}$$

The heating value of the gas is 53,000 foot-pounds (p. 327);

$$\begin{aligned} \therefore \text{efficiency} &= \frac{\text{heat converted into work}}{\text{heat supplied}} \\ &= \frac{20,900}{53,000} \\ &= 0.394 \text{ or } 39.4 \text{ per cent.} \end{aligned}$$

This is the efficiency of an ideal engine using the actual working substance with adiabatic compression and combustion in which the expansion line follows the law $p v^{1.20} = \text{constant}$. As already pointed out, this is not an adiabatic expansion line, but possesses the property that

no heat is lost or gained in the course of it, the loss of energy in the early parts being balanced by an equal gain in the latter parts. The true adiabatic for which n is an increasing quantity, at first greater and afterwards less than 1.20, will be at first above the assumed line, will cross it, and will finally be below it. The final temperature after true adiabatic expansion will be less than after the assumed expansion. Since no heat is lost to the walls (on the whole) in either case, it follows that the work area under the true adiabatic line must be slightly greater than under the line $p v^{1.2} = \text{constant}$. Thus the efficiency calculated above is a little lower than that of an engine using real adiabatic expansion, but it is easy to prove that the difference is appreciable.

II. Weak Mixture (A).—It is unnecessary to go through all the steps of the calculation with the weaker mixture. The following are the results which should be worked out by the reader following the above method :—

$$\begin{array}{l}
 \text{Compression work (as before)} = 7,700 \\
 \text{Heat in gas} = 0.094 \times 0.93 \times 600 \times 778 = 40,700 \\
 \text{Internal energy after explosion} = 48,400
 \end{array}
 \left. \begin{array}{l} \\ \\ \end{array} \right\} \begin{array}{l} \text{foot-pounds per} \\ \text{cubic foot of mix-} \\ \text{ture from } 100^\circ \text{ C.} \end{array}$$

$$\text{Energy per cubic foot of products} = \frac{48,400}{0.971} = 49,800 \text{ foot-pounds}$$

Corresponding temperature from curve (Fig. 150) = 1940° C. = 2210° absolute. Assuming the expansion curve $p v^{1.24} = \text{constant}$, the final temperature is 1418° absolute or 1145° C. The energy (from the curve) is then 24,000 foot-pounds.

$$\begin{array}{r}
 \text{Loss of energy} = 25,803 \\
 \text{Work area under expansion curve} = 32.3 \times 792 = 25,600 \\
 \left. \begin{array}{l} \text{Work of expansion per standard} \\ \text{cubic foot of mixture} \end{array} \right\} = 25,600 \times 0.975 = 24,950 \\
 \text{Net work} = 17,250 \\
 \text{Heat supply} = 40,700 \\
 \text{Efficiency} = 42.4 \text{ per cent.}
 \end{array}$$

The difference between the efficiencies with the two mixtures is mainly due to the fact that a greater rise of temperature, and therefore of pressure (in proportion to the fuel used) is obtained when exploding the weak than when exploding the strong mixture. The temperature rises are 1700° and 1430° respectively, and are in the ratio 1.19, but the amounts of fuel supplied are in the ratio of 1.30. The pressure falls rather more rapidly in the adiabatic expansion of the weaker mixture, but the difference in this respect is not very material. The determining factor is the initial pressure produced by the explosion (see Art. 168).

191. By Wimperis's Formula.—Mr. Wimperis¹ in his book on the internal combustion engine deduces the following expression for the ideal efficiency of a gas engine assuming the specific heat to be a linear function of the temperature ($C_p = \beta_1 + sT$).

$$E = \eta \left\{ 1 - \frac{s}{2\beta_1} (\overline{1 - \eta} \cdot T_2 + T_0) \right\} \dots \dots (1)$$

¹ See "The Internal Combustion Engine," p. 85. Constable & Co.

where η = air standard efficiency
 T_2 = maximum absolute temperature (Centigrade)
 T_0 = suction temperature (absolute)

and β_1 and s are the constants in the equation $C_v = \beta_1 + sT$.

Using the value given by Dugald Clerk for an average working mixture for C_v , namely $C_v = 0.194 + 0.051 \frac{t}{1000}$ (Art. 186), this equation (1) becomes ¹

$$E = \eta \left\{ 1 - \frac{1}{7000} \sqrt{1 - \eta \cdot T_2 + T_0} \right\} \dots \dots (2)$$

The air standard efficiency is

$$\begin{aligned} \eta &= 1 - \left(\frac{1}{6.37} \right)^{0.4} \\ &= 1 - 0.477 \\ &= 0.523, \text{ or } 52.3 \text{ per cent.} \end{aligned}$$

Taking the same values for T_2 and T_0 as in Art. 190, namely, $T_2 = 2480^\circ$ absolute and $T_0 = 373^\circ$ absolute, the efficiency becomes for the strong mixture—

$$\begin{aligned} E &= 0.523 \left\{ 1 - \frac{1}{7000} \sqrt{1 - 0.523 \cdot 2480 + 373} \right\} \\ &= 0.523 \left\{ 1 - \frac{1183 + 373}{7000} \right\} \\ &= 0.523 \{ 1 - 0.2223 \} \\ &= 0.523 \times 0.777 \\ &= 0.406, \text{ or } 40.6 \text{ per cent.} \end{aligned}$$

For the weak mixture, in which $T_2 = 2210^\circ$ absolute,

$$\begin{aligned} E &= 0.523 \left\{ 1 - \frac{1}{7000} \sqrt{1 - 0.523 \cdot 2210 + 373} \right\} \\ &= 0.523 \left\{ 1 - \frac{1054 + 373}{7000} \right\} \\ &= 0.523 \{ 1 - 0.204 \} \\ &= 0.523 \times 0.796 \\ &= 0.416, \text{ or } 41.6 \text{ per cent.} \end{aligned}$$

¹ At the absolute zero ($T = 0$ or $t = -273$), $C_v = \beta_1$

Using $C_v = 0.194 + 0.051 \frac{t}{1000}$ where $t = -273^\circ \text{C}$.

$$C_v = 0.194 - \frac{0.051 \times 273}{1000} = 0.180$$

$$\therefore \beta_1 = 0.180$$

$$\text{and } \frac{s}{2\beta_1} = \frac{0.051}{2 \times 0.18} \times \frac{1}{1000} = \frac{0.051}{360} = \frac{1}{7000} \text{ approximately}$$

CHAPTER XV

THEORY OF THE OIL ENGINE

192. The Diesel Engine.—The Diesel engine has been developed, both as a four-stroke and a two-stroke cycle engine, exclusively as an oil engine using crude oil, and works on a cycle which approximates to the ideal constant pressure cycle already considered in Art. 165. The development of this engine is proceeding so rapidly that, although at present the four-stroke cycle engine may be regarded as the standard type for stationary

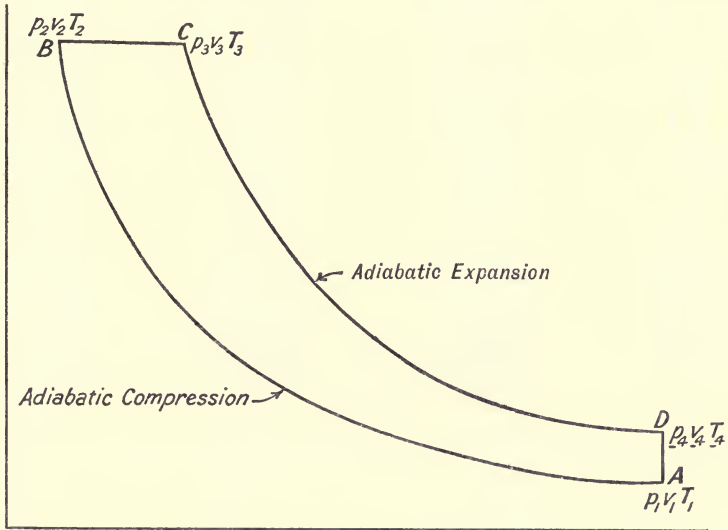

FIG. 151.

plants up to about 600 horse-power, and the two-stroke for larger powers, it is probable that in the near future the double-acting two-stroke cycle may become the standard type for all powers.

The ideal cycle considered in Art. 165 assumed complete adiabatic expansion down to atmospheric pressure. The Diesel engine differs from this cycle inasmuch as the expansion ends when the volume is the same as that at which compression begins, as shown in Fig. 151.

Let the conditions be at A $p_1v_1T_1$, at B $p_2v_2T_2$, at C $p_3v_3T_3$, and at D $p_4v_4T_4$, then

$$\text{Heat received at constant pressure} = C_p(T_3 - T_2)$$

$$\text{Heat rejected at constant volume} = C_v(T_4 - T_1)$$

$$\text{Heat converted into work} = C_p(T_3 - T_2) - C_v(T_4 - T_1)$$

$$\begin{aligned} \text{Efficiency} &= \frac{C_p(T_3 - T_2) - C_v(T_4 - T_1)}{C_p(T_3 - T_2)} \\ &= 1 - \frac{T_4 - T_1}{\gamma(T_3 - T_2)} \end{aligned}$$

This efficiency is less than that of the ideal constant pressure cycle discussed in Art. 165, and also less than that of the ideal constant volume cycle discussed in Art. 163. On the other hand, by compressing to a very high pressure, and therefore using a greater ratio of compression than

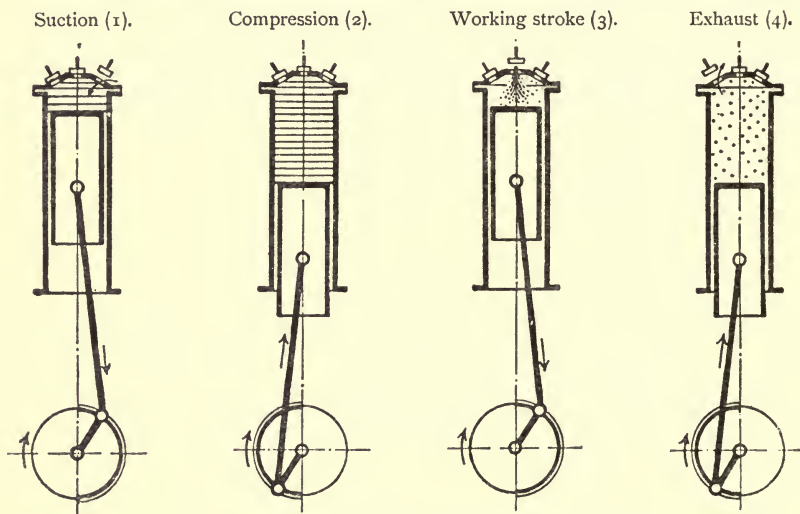

FIG. 152.—Four-stroke cycle.

is usual in constant-volume engines, the actual Diesel engine has a higher thermal efficiency than the constant-volume engines. This is rendered possible because the oil fuel is admitted at the end of the compression stroke, and there is no risk of pre-ignition.

The four-stroke single-acting cycle is shown diagrammatically in Fig. 152, the corresponding indicator diagram being given in Fig. 153. The cycle is as follows:—

(1) *Suction Stroke*.—The engine takes in air alone at atmospheric pressure and temperature.

(2) *Compression*.—The air is compressed to a high pressure (about 35 atmospheres or 500 pounds per square inch absolute), and to a temperature of about 1000°F .

(3) *Working Stroke*.—During the first portion of this stroke oil is sprayed into the cylinder, the quantity admitted being controlled by the

governor. Slow combustion of this fuel results at constant pressure ; there is no explosion. The second part of the stroke is approximately an adiabatic expansion.

(4) *Exhaust.*—The products of combustion are exhausted from the cylinder.

The two-stroke single-acting cycle is shown diagrammatically in Fig. 154, the corresponding indicator diagram being given in Fig. 155. The cycle is as follows:—

(1) *Scavenging and Inlet of Pure Air.*—After the end of a working stroke, during the time that the piston uncovers the ports in the cylinder walls, a fresh charge of air is admitted into the cylinder.

(2) *Compression.*—The air is compressed as in the four-stroke cycle.

(3) *Working Stroke.*—This stroke is carried out exactly the same as in the four-stroke cycle.

Indicator Diagram of single-acting Diesel engine. (Taken from original diagram.)

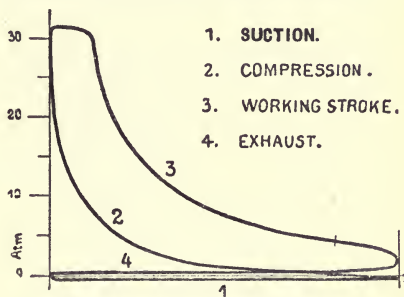

FIG. 153.—Four-stroke cycle.

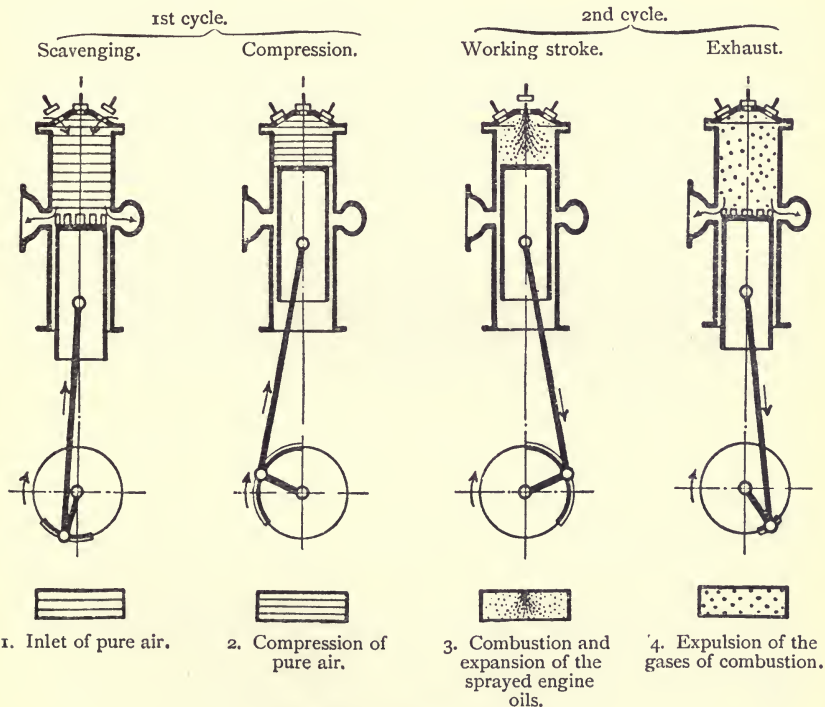

FIG. 154.—Two-stroke cycle.

(4) *Exhaust and Scavenging.*—Towards the end of the working stroke the piston uncovers the ports in the cylinder walls, air is then admitted under pressure and drives out the products of combustion, and the cycle is then repeated.

It will be seen that the two-stroke Diesel cycle is very similar to the two-stroke gas engine cycle which has been discussed in Art. 172. In

Indicator Diagram of single-acting Diesel engine. (Taken from original diagram.)

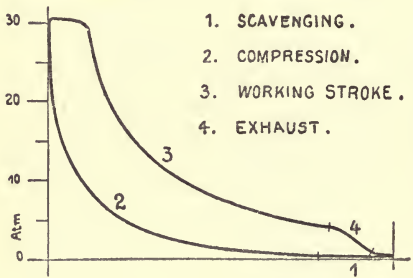

FIG. 155.—Two-stroke cycle.

the gas engine, however, the combustible mixture is admitted into the cylinder by a special gas pump before the exhaust ports are entirely closed, and in all probability some of the fuel escapes unused into the exhaust.¹ In the Diesel engine the fuel is only admitted at the end of the compression stroke, thus preventing any loss of fuel and danger of pre-ignition. In addition, the Diesel engine has the advantage that the bulky and power-absorbing gas pump can be dispensed with. On the other hand, a small air pump is required to spray the

fuel into the cylinder against the high compression pressure. The fuel consumption per horse-power hour is slightly higher on the two-stroke than on the four-stroke cycle, due to the extra power absorbed by the scavenging air pump, and also to the short time available for scavenging which does not allow as good a scavenging as with the four-stroke cycle.

Maximum Power per Cylinder.—The largest oil engines made work on the Diesel principle. The maximum power obtained per cylinder with a single-acting engine on the four-stroke cycle is about 250 H.P. The largest horizontal Diesel engine built by the Maschinenfabrik Augsburg-Nurnberg (M.A.N.) is a double-acting four-stroke cycle tandem twin engine, of 1600–2000 H.P. or 400–500 H.P. per cylinder, with a speed of 150 revolutions per minute. The largest vertical double-acting two-stroke cycle marine engines (M.A.N.) have yielded 2500 H.P. per cylinder, so that an engine with six cylinders would give 15,000 H.P., or 45,000 H.P. for a vessel with three propellers.²

For descriptions of actual engines the reader is referred to the following short list taken from many admirable papers:—"The Diesel Engine," by Mr. H. Ade Clark, *Proc. I. Mech. E.*, 1903, p. 395; "Modern Diesel Engines," by Mr. J. F. Schubeler, *Proc. I. Mech. E.*, 1911, p. 579; "The Diesel Engine," by Mr. H. S. Pursey, *Proc. I. Mech. E.*, 1912, p. 281; "The Diesel Engine and its Industrial Importance, particularly for

¹ In the Koerting engine the gas and air are admitted by separate pumps, which in the first instance deliver pure air into the cylinder, and then a mixture of uniform composition the quantity of which alone varies to regulate the power of the engine. By this means the loss into the exhaust is reduced, there being a layer of air between the exhaust gases and the incoming mixture. See a paper by M. R. E. Mathot, *Proc. I. Mech. E.*, 1905, p. 645, on "The Growth of Large Gas Engines on the Continent."

² See a paper by Dr. Rudolph Diesel, *Proc. I. Mech. E.*, 1912, p. 202.

Great Britain," by Dr. Rudolph Diesel, *Proc. I. Mech. E.*, 1912, p. 179; "Modern Developments in British and Continental Oil Engine Practice," by Mr. E. Shackleton, *Trans. Inst. of Marine Engineers*, vol. xxii. p. 157, 1911.

193. The Hornsby Oil Engine.—In its ordinary form this engine is designed to use either refined or crude oil. The combustion of the fuel is obtained automatically at constant volume without employing any special ignition device. In common with many other oil engines working on the four-stroke constant volume cycle, the oil is vapourised in a "vapouriser," which forms part of the combustion chamber. On starting the engine, the vapouriser is heated externally by means of a coil lamp, and when hot enough the engine is pulled round by hand (or else started by compressed air). The engine on the suction stroke draws in a charge of air, and on the inner dead centre oil is injected into the hot vapouriser through a very fine orifice in the form of a thin jet; the amount of oil so admitted is regulated by the governor to suit the load on the engine. The oil is vapourised almost immediately, and at the end of the suction stroke the cylinder and combustion chamber is full of an inflammable mixture of air and oil vapour. The return stroke of the piston compresses the mixture to such a pressure that just after the end of the compression stroke is reached, the pressure (in conjunction with the temperature) is sufficient to automatically explode the mixture and give an impulse to the piston as it commences to move off on its working stroke. The working stroke is an approximate adiabatic expansion, being followed by exhaust in the usual way.

After the first explosion has been obtained, the heat of successive explosions is sufficient to maintain the end of the vapouriser hot enough without the use of the external lamp. From lighting the lamp to getting full load on the engine takes on an average from 10–15 minutes. One great advantage of this engine is its simplicity, there being no ignition device and practically nothing to go wrong; and further, there is no excessive pressure before combustion.

The satisfactory working of this engine depends almost entirely on the compression pressure and the design of the vapouriser. The higher the flash point of the oil fuel used the larger must be the internal surface area of the vapouriser and the higher the compression pressure. Different oils therefore require different vapourisers, the volumes of which are arranged to give the ratio of compression required, and the required vapourising surface is obtained by casting internal ribs to the vapouriser when required. When the engine is set for Russolene (H.V.O.) of average specific gravity 0.824, and flash point 105° F. (about), the required compression pressure (obtained experimentally in the first instance) is about 70 pounds per square inch above atmospheric. With Royal Daylight of average specific gravity 0.80, and flash point about 95° F., the required compression pressure is about 55 pounds per square inch above atmospheric. The vapouriser is made in two parts, the one bolted directly to the end of the cylinder is water-jacketed, the other part, known as the "cap end," is non-jacketed and bolted to jacketed part. A separate "cap end" is supplied for each oil fuel, and the compression pressure can be further adjusted by means of compression blocks in the water-jacketed portion of the vapouriser, which blocks alter the clearance volume.

194. Other Types of Heavy Oil Engine.—The majority of other types of oil engine use an ignition tube for firing the mixture of oil vapour and air, and can be broadly classified in two types. The Crossley, Gardner, Blackstone, Clayton and Shuttlesworth, and many other engines work as follows:—

A small vapouriser is kept red-hot by the flame from a lamp, which also heats the ignition tube, and the charge of oil is delivered by a pump through the vapouriser with a little hot air, which carries the oil vapour through a separate valve into the cylinder; the main supply of *cold* air is admitted through another valve. The mixture is then compressed and exploded by the ignition tube when the piston commences its working stroke.

In the Campbell and Tangyes oil engines *each charge of oil is drawn in with the whole charge of cold air* by a valve through the vapouriser into the combustion chamber; the mixture is then compressed and ignited by an ignition tube as above.¹ In all the above engines moderate compression pressures are used, varying from about 50 to 60 pounds per square inch above atmospheric, the efficiency being considerably less than that of the Diesel engine.

Many manufacturers now make oil engines using crude residuum oils, which work on a system that may be called a compromise between the Diesel system and others, and whilst their fuel consumption is not quite so low as the Diesel, has the advantage of giving a much lighter and cheaper engine in first cost.

195. Petrol Engines.—In this type of internal combustion engine the working fluid is a mixture of air and petrol vapour; the principle of working is the same as that of a gas or oil engine, and both the four-stroke and the two-stroke constant volume cycles are used. The remarks already made on the theory of the gas and oil engine apply equal well to the petrol engine, with the sole exception of the effect of the speed of the engine. The high speed necessitates some special timing arrangement being provided, in order to time the passage of the spark, and to get the explosion just as the piston commences its working-stroke. In a four-stroke engine, running at 1200 revolutions per minute, the piston makes one complete stroke in $\frac{1}{40}$ of a second, and since it takes an appreciable time for the ignited mixture to attain its maximum pressure after ignition commences, it is evident that the spark must be timed to pass in the combustion chamber before the piston has completed the compression stroke. The time of ignition at this high speed, however, will not be suitable for a lower speed, the lower the speed the later should be the time at which the spark passes, hence it is essential that the time of ignition may be varied to suit the speed at which the engine is running. This is more important with the petrol engine than the gas engine, since the latter runs at a comparatively low speed, and it is only necessary to retard the spark when starting, and then to advance it as the gas engine gets up speed.

The explosive mixture of petrol vapour and air is produced by the piston drawing air through a carburettor containing petrol, the intermingling of the air and petrol being either produced by surface evaporation of the petrol or by the jet method. In the surface method the air is drawn over a petrol-soaked surface and takes up petrol vapour; in the jet

¹ For a detailed description of these and other types of oil engines, see Robinson's "Gas and Petroleum Engines" (Spon).

method the petrol is drawn into the air stream as a jet, from which it is evaporated and carried off with the air into the cylinder. In either method the whole of the air supply may pass through the carburettor, or else a portion only, the remaining air being added afterwards, in order to obtain the strength of mixture required.¹

Effect of Strength of Mixture.—Results of numerous experiments show that the efficiency of a petrol engine varies with the strength of mixture. Dr. Watson finds that in a two-stroke engine the efficiency increases as the richness of the mixture is reduced below the point at which complete combustion takes place, *i.e.* for mixtures containing less than one of petrol to fourteen of air by weight.² This result, whilst it agrees with those he had previously obtained with a four-stroke engine,³ does not agree with the results obtained by Professor Hopkinson,⁴ who found that the efficiency was a maximum when there was just sufficient oxygen to give complete combustion, *i.e.* when the ratio of air to petrol by weight was 14 : 1.

Dr. Watson says: "When comparing the working of this two-stroke engine with an ordinary four-stroke engine, it is to be noted that the range of mixture richness which it is possible to use is considerably smaller with the two-stroke than with the four-stroke, due to the very much larger admixture of exhaust products with the fresh charge. Unless the richness of mixture is adjusted within comparatively narrow limits, particularly at high speeds, the engine refuses to work on the two-stroke cycle, and only fires on every other out stroke, the intermediate stroke acting as a scavenging stroke. The result of this peculiarity is, that unless the carburettor provides a mixture of uniform richness at different speeds and for different throttle openings, satisfactory working cannot be obtained. In the case of the engine under test the effective use of the carburettor jet was hand-adjusted in every case, but even then, at a speed of 1500 revolutions per minute, it was often difficult to exactly hit off the correct mixture."

Effect of Cylinder Dimensions on Efficiency.—In large gas engines the efficiency is little affected by an increase or decrease in the cylinder diameter (Art. 183), but in small petrol engine cylinders the effect is considerable. The actual efficiency of all internal combustion engines is, of course, always less than the ideal air standard efficiency discussed in Art. 163, due to the variation in the specific heat of the gases and also to the heat losses which result from the expansion and compression not being adiabatic. Professor Callendar⁵ has shown that the most important loss is roughly proportional to $\frac{1}{D}$ where D is the diameter of the cylinder, and

making allowance for the variation of specific heat of the gases, the ideal efficiency of an engine working on the constant volume cycle is approximately 0.75 of the efficiency of the air standard. From this it would appear that even the largest engines cannot get nearer the "air standard" efficiency than 75 per cent.

If E denotes the "air standard" efficiency, and D the diameter of the

¹ For a description of various types of carburettors, see Wimperis's "Internal Combustion Engines." Constable.

² *Proc. Inst. A. E.*, 1910.

³ *Proc. Inst. A. E.*, vol. iii. p. 387, 1908-9.

⁴ *Proc. Inst. A. E.*, vol. iii. p. 220, 1908-9.

⁵ *Proc. Inst. C. E.*, vol. clxix., 1907, p. 163.

cylinder in inches, then, according to the above statement, the actual thermal efficiency (estimated on the indicated horse-power) will be

$$0.75E\left(1 - \frac{1}{D}\right)$$

In his tests mentioned above, Dr. Watson found the efficiency of a four-stroke petrol engine of bore 85 mm. to be 0.77 of the air standard, whilst with a two-stroke engine of bore 82.5 mm. the relative efficiency was 0.76. This result supports the view that the thermal loss in these small engines does not vary to any great extent with the ratio of surface to volume of the combustion chamber.

CHAPTER XVI

TESTING OF INTERNAL COMBUSTION ENGINES

196. Commercial Tests.—The majority of tests on internal combustion engines are carried out for a commercial purpose in order to (*a*) see if the engine will develop its rated power with the guaranteed fuel consumption; (*b*) to test the timing of the valves and also the quantity of lubricating oil and cooling water used per brake horse-power hour; (*c*) to observe the steadiness of running under different loads; (*d*) to determine the overload which the engine will stand for varying periods.

On account of the difficulty in accurately measuring the indicated horse-power developed, the manufacturer invariably works to the brake horse-power, and if the engine develops its rated brake horse-power with economy, the satisfaction of both customer and manufacturer is assured.

197. Scientific Tests.—A complete thermodynamic trial is a very different thing to the commercial test. The principal necessary measurements to be made are:—

- (*a*) Indicated horse-power.
- (*b*) Brake horse-power.
- (*c*) Fuel consumption and heat supplied to the engine by the fuel.
- (*d*) Heat carried into the engine by the air supply.
- (*e*) Heat brought in and carried away by the jacket water.
- (*f*) Heat carried away by the exhaust gases.

198. Indicated Horse-Power.—In the case of gas engines it is an extremely difficult operation to determine *accurately* the indicated horse-power. The strength of the spring to be used in the indicator must be carefully chosen. The ratio of the maximum pressure in the engine cylinder to the mean pressure during the cycle is very much greater than the same ratio for any other type of engine. The maximum pressure may be about 500 lbs. per square inch, whilst the mean pressure would be, say, in the neighbourhood of 80 lbs. to 100 lbs. per square inch, and the explosion, taking place at constant volume, causes this maximum pressure to be reached practically instantaneously. Hence the natural period of vibration of the indicator spring must be very much less than the time between successive explosions. To this end the spring used must be stiff enough to prevent vibrations from being set up, and thus giving a wavy expansion line. If the spring used be too stiff, then the diagram is so small that an accurate determination of the mean pressure is impossible. It is obvious, therefore, that a careful choice of the type of indicator to be used is necessary. If a pencil indicator be used it should be carefully

selected, and should have hardened steel joints to minimise the wear. The chief causes of error in pencil indicators other than looseness of the joints are: (1) Friction of the piston and pencil; (2) stretch of the indicator cord. The effect of friction is to increase the mean effective pressure, because the pencil tends to lag all the time, as shown in Fig. 156.

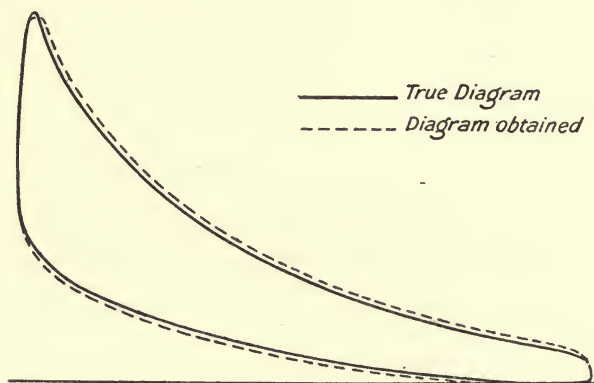

FIG. 156.

The effect of the stretching of the cord is shown in Fig. 157. During the first half of the stroke the actual pressure shown is considerably less than the true pressure, but towards the end of the diagram the error is much

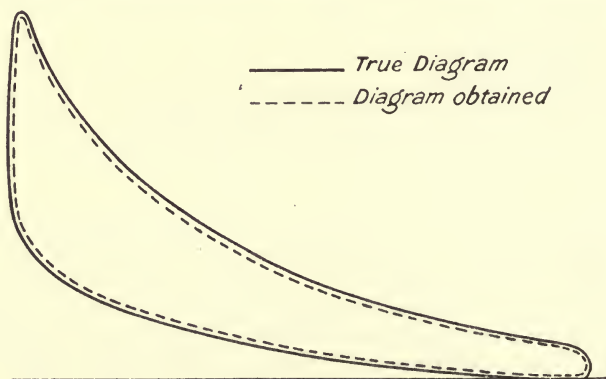

FIG. 157.

less. The error in the pressure is positive owing to friction and negative owing to the stretch of the cord, hence one error tends to neutralise the other. With the greatest care in taking the diagrams the error due to these causes may be reduced to about 2 per cent.¹

¹ For a research on the errors of indicators, see a paper on "Indicators" by Mr. J. G. Stewart, *Proc. Inst. Mech. E.*, January, 1913.

Hints on taking Indicator Diagrams.—The piston should be an easy fit in the indicator cylinder, so that when cold the piston drops from top to bottom freely. The motion work should be quite free from any looseness or back lash, and every care should be taken to see that the connection between the piston and motion is correct. The indicator drum should be driven through a steel wire held taut by means of a powerful spring, so that there is no back-lash in that direction, and also a minimum amount of stretching of the driving wire or cord. The spring in the indicator drum should also be powerful, so as to overcome the inertia of the drum and also prevent back-lash. In taking the diagrams the pencil should be pressed very lightly against the paper to reduce the friction there. The diagrams should be taken at frequent intervals, say every two minutes during a trial of one hour's duration. The diagrams should then be measured up by the method of ordinates, the average of each ordinate found, and a new diagram plotted. This diagram will then represent a mean indicator diagram for the complete trial, from which the mean effective pressure may be obtained.

The use of an optical indicator reduces the errors due to friction, back-lash, and inertia, and for high-speed engines this indicator is perhaps the only reliable one to use, if the object is to find the mean effective pressure.¹ From the results of numerous experiments it appears that when used on modern gas engines running at the normal speeds used in practice, there is little to choose between the Crosby gas engine indicator and Hopkinson's optical indicator.²

For rapid determinations of the mean effective pressure a planimeter may be used, being quite accurate enough for all ordinary practical purposes.

The remaining data required for the calculation of the indicated horse-power are the number of explosions per minute and the dimensions of the engine cylinder. The number of explosions per minute is best given by means of a counter arranged to be actuated from the gas valve, particularly if the engine governs on the hit and miss method. The indicated power is then the mean effective pressure obtained from the *positive* loop of the diagram multiplied by the number of explosions per minute and by the appropriate constant for reducing to horse-power, *i.e.*

$$\text{Indicated horse-power} = \frac{p \cdot l \cdot a \cdot n}{33,000} \dots \dots \dots (1)$$

where p = mean effective pressure (lbs. per square inch) obtained as above.

l = length of stroke in feet.

a = cross-sectional area of cylinder.

n = number of explosions per minute.

199. Brake Horse-Power.—There is very little difficulty in measuring this quantity accurately if ordinary precautions are used. A rope brake

¹ For a description of a new optical indicator, see a paper by Prof. Hopkinson in *Proc. Inst. Mech. E.*, October, 1907.

² For a comparison between Hopkinson's optical indicator and the Crosby gas engine indicator, see "The Indicating of Gas Engines," by Prof. Burstall, *Proc. Inst. Mech. E.*, 1909, p. 785.

of the type shown in Fig. 158 may be used for most purposes. The brake horse-power is then given by—

$$\frac{(W - S)CN}{33,000} \dots \dots \dots (1)$$

where $W - S$ = effective load on brake in pounds.

C = effective circumference of brake wheel in feet

= circumference of brake wheel + circumference of rope.

N = revolutions per minute.

• The mechanical efficiency is then the usual relation $\frac{\text{B.H.P.}}{\text{I.H.P.}}$

The difference between the indicated and brake horse-power is known

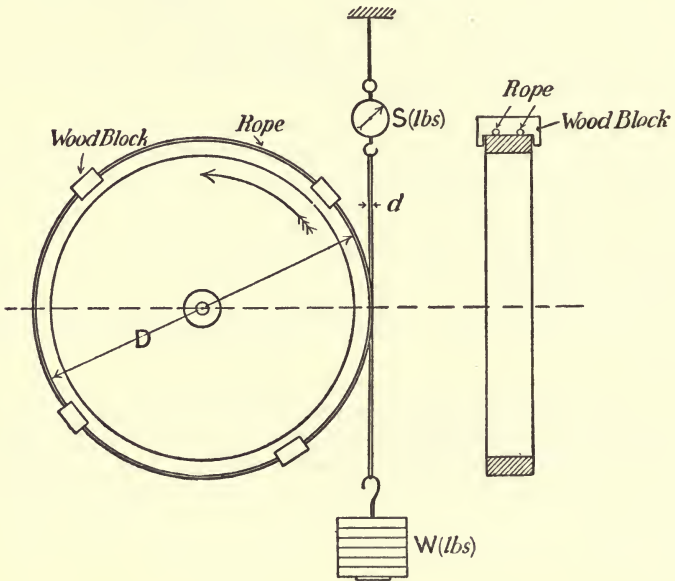

FIG. 158.

as the mechanical loss, and includes the negative loop of the indicator diagrams and also the negative work done when the engine takes no gas.

The following method, devised by Mr. Morse, of obtaining the mechanical efficiency of a multi-cylinder engine eliminates the necessity of using an indicator. It consists in running the engine fully loaded with all the cylinders working. The load is put on by means of a Prony brake clamped to the flywheel or brake-wheel, carrying a dead weight which is partially supported by a spring balance. The spring balance reads the excess of the dead weight over the brake load in the usual manner, and small changes in the brake load may be very accurately read. In making the test, one cylinder is stopped from firing and the pressure on the brake blocks is reduced until the engine is again running at its normal speed. The reduction in brake load is then read off, and is approximately that

corresponding to the indicated power of the cylinder which has been cut out. The other cylinders are treated in succession in this manner, and by adding the results the indicated horse-power of the engine is determined.

200. Fuel Consumption.—The most reliable method of measuring the gas consumption of an engine is to pass the gas into a graduated gas-holder, from which it is drawn by the engine. This is more accurate than trusting to the readings of a gas meter, but either method may be used, depending upon the object of the trial. For a complete thermodynamic trial the gas-holder should be used, whilst for a commercial test the gas meter would probably be most suitable. The temperature and pressure of the gas should be taken, so that the volume used may be reduced to standard temperature and pressure, *i.e.* 0°C . or 32°F . and 760 mm. of mercury or 29.92 inches of mercury. The commercial test is often given in terms of cubic feet of gas per brake horse-power hour at 60°F . and standard atmospheric pressure, since this temperature is about the average at which the gas would be delivered to the engine in practice.

A trial of one hour's duration should be ample, and if the engine has settled down to its working conditions, half an hour or even less should suffice to measure the gas consumption and indicated horse-power, etc.

In the case of a gas suction plant the coal consumption per horse-power hour is required, and this will necessitate a trial under steady load of at least six hours' duration. The gas producer should be filled up at the commencement of the trial and weighed amounts of coal added at regular intervals, the producer being as full at the end as at the commencement of the trial.

In the case of an oil engine trial the oil pump suction may be connected directly to the oil tank. This tank should have a narrow neck fitted with a gauge hook. At the commencement of the trial the point of the hook should be just at the surface of the oil, and the weight of oil which must be added during the trial so that the level of the oil is the same at the end will give the oil consumption during the trial.

EXAMPLE 1.—The following particulars were obtained during a trial on a 25 brake horse-power Campbell gas engine in the heat engine laboratory of University College, Nottingham:—

Duration of trial, one hour; total revolutions of engine = 13,602; total number of explosions, 4620; nett load on brake, 277 lbs.; mean effective pressure on piston, 106 lbs. per sq. in.; gas consumption as registered by meter, 455.5 cubic feet; lower calorific value = 592 B.Th.U. per cubic foot at N.T.P.; pressure of gas, 771 mm.; temperature of gas passing through meter, 15°C .; diameter of cylinder, $9\frac{1}{2}$ inches; stroke, 19 inches; effective circumference of brake, 12.8 feet. Work out (a) the indicated horse-power; (b) brake horse-power; (c) mechanical efficiency; (d) thermal efficiency; (e) overall efficiency.

$$(a) \text{ Explosions per minute} = \frac{4620}{60} = 77.$$

By (1), Art. 198,

$$\text{I.H.P.} = \frac{0.7854 \times (9.5)^2 \times 106 \times 19 \times 77}{12 \times 33,000} = 28.2$$

$$\text{revolutions per minute} = \frac{13,602}{60} = 226.7$$

(b) By (1), Art. 199,

$$\text{B.H.P.} = \frac{277 \times 12.8 \times 226.7}{33,000} = 24.37$$

(c) Mechanical efficiency = $\frac{\text{B.H.P.}}{\text{I.H.P.}} = \frac{24.37}{28.2} = 86.4$ per cent.

(d) Now gas used per hour at 15° C. and 771 mm. pressure = 455.5 cubic feet. Hence reducing to standard temperature and pressure (0° C. and 760 mm.), this becomes—

$$455.5 \times \frac{273}{273 + 15} \times \frac{771}{760} = 438 \text{ cubic feet}$$

$$\text{Hence gas per I.H.P. per hour} = \frac{438}{28.2} = 15.53 \text{ cubic feet}$$

Since one horse-power hour = 2545 British thermal units

$$\text{thermal efficiency} = \frac{2545}{592 \times 15.53} = 27.68 \text{ per cent.}$$

(e) Overall efficiency = thermal efficiency \times mechanical efficiency
 $= 0.2768 \times 0.864$
 $= 0.2392$
 $= 23.92$ per cent.

The overall efficiency can also be calculated as follows:—

$$\text{Gas per B.H.P. hour at N.T.P.} = \frac{438}{24.37} = 17.97 \text{ cubic feet}$$

$$\text{Hence overall efficiency} = \frac{2545}{492 \times 17.97} = 23.92 \text{ per cent.}$$

EXAMPLE 2.—In a test with the above engine working on suction gas the following data was obtained:—

Duration of trial, 6 hours; average speed of engine, 224 revolutions per minute; average explosions per minute, 96.2; mean effective pressure, 75.4 lbs. per sq. in.; effective load on brake, 252 lbs.; coal consumption, 20.3 lbs. per hour; calorific value of coal (lower value), 15,020 B.Th.U. per lb. Work out (a) I.H.P.; (b) mechanical efficiency; (c) overall efficiency; (d) thermal efficiency of producer.

$$(a) \text{ I.H.P.} = \frac{0.7854 \times (9.5)^2 \times 75.4 \times 96.2 \times 19}{33,000 \times 12} = 25.1$$

$$(b) \text{ B.H.P.} = \frac{12.8 \times 224 \times 252}{33,000} = 21.9$$

$$\therefore \text{mechanical efficiency} = \frac{21.9}{25.1} = 87 \text{ per cent.}$$

$$(c) \text{ Coal per B.H.P. hour} = \frac{20.3}{21.9} = 0.93 \text{ lb.}$$

$$\therefore \text{overall efficiency} = \frac{2545}{0.93 \times 15,020} = 18.2 \text{ per cent.}$$

(d) Overall efficiency = thermal efficiency of engine \times mechanical efficiency \times thermal efficiency of producer.

$$\text{Coal per I.H.P. hour} = \frac{20.3}{25.1} = 0.808 \text{ lb.}$$

$$\therefore \text{thermal efficiency of engine and producer} = \frac{25.45}{0.808 \times 15,020} = 20.9\%$$

$$\text{Hence thermal efficiency of producer} = \frac{0.182}{0.209} = 87.0 \text{ per cent.}$$

EXAMPLE 3.—Draw up an approximate heat balance from the following particulars obtained from a trial on a Diesel oil engine:—

Duration of trial	one hour.
Average speed	157 revs. per min.
Indicated horse-power	126.6.
Brake horse-power	87.2
Total oil consumed	40.58 lbs.
Calorific value of oil	19,300 B.Th.U. per lb.
Analysis of oil	C = 85 %; H = 13.5 %; incombustible, 1.5 %
Analysis of exhaust gases by volume }	CO ₂ = 4.3 %; CO = nil; O ₂ = 14.8 %; N ₂ = 80.9 %
Temperature of exhaust	492° F.
Temperature of engine room	60° F.
Cooling water per minute	43.0 lbs.
Inlet temperature	49° F.
Outlet temperature	126.5° F.

The items to be worked out are per lb. of oil:—

- (1) Heat converted into work in engine cylinder.
- (2) Heat rejected to cooling water.
- (3) Heat rejected in exhaust.
- (4) Unaccounted for.

(1) *Heat converted into work.*

$$\text{Oil per I.H.P. hour} = \frac{40.58}{126.6}$$

$$\begin{aligned} \therefore 1 \text{ lb. of oil gives } \frac{126.6}{40.58} &= 3.119 \text{ I.H.P. hours.} \\ &= 3.119 \times 2545 \text{ B.Th.U.} \\ &= 7938 \text{ B.Th.U.} \end{aligned}$$

(2) *Heat rejected to cooling water* per minute = $43(126.5 - 49)$
= 3332 B.Th.U.

$$\text{Oil used per minute} = \frac{40.58}{60} = 0.676 \text{ lb.}$$

$$\therefore \text{heat rejected to cooling water per lb. of oil} = \frac{3332}{0.676} = 4929 \text{ B.Th.U.}$$

(3) *Heat rejected in exhaust.* To estimate this approximately we require the air supplied per lb. of oil burned as follows. By equation (3), Art. 144,

$$\text{air supplied per pound of oil} = \frac{80.9}{33 \times 4.3} \times 85 = 48.2 \text{ pounds}$$

\therefore weight of exhaust gases per pound of oil = 49.2 pounds (approximately). Assuming the specific heat of the exhaust gases to be 0.25, we have heat rejected to exhaust per pound of oil = $49.2 \times 0.25(492 - 60)$
= 5314 B.Th.U.

The heat balance will therefore be:—

	B.Th.U.	Per cent.
Heat in 1 pound of oil	19,300	100.0
Heat equivalent of I.H.P.	7,938	41.12
Heat rejected to cooling water	4,929	25.53
Heat rejected in exhaust	5,314	27.53
Unaccounted for	1,119	5.82
Total	19,300	100.00

201. Heat supplied to the Engine by the Gas.—In the case of a gas engine the heat supplied in the fuel should be reckoned from 32° F. as recommended in the Report of the Committee on the Efficiency of Internal Combustion Engines.¹

Let v = volume of gas supplied per hour in cubic feet,
 ρ = density of the gas in pounds per cubic foot,
 c = lower calorific value of the gas in B.Th.U. per cub. foot at N.T.P.,
 s = specific heat of the gas,
 t = temperature of the gas in ° F.,
 H = total heat of the moisture in the gas per hour.

Then

heat supplied by the gas per hour = $vc + \rho vs(t - 32) + H$ B.Th.U.

202. Heat carried into the Engine by the Air Supply.—The calculation of this item requires the measurement of the quantity of air supplied, and also an estimation of the amount of moisture present in the air. The air supply may be measured by means of a gas-holder, or by means of an anemometer,² by the flow through an orifice,³ or may be estimated from the analysis of the gas and exhaust gases (Art. 144).

Let V = volume of air supplied per hour in cubic feet,
 d = density of air in pounds per cubic foot,
 w = weight of water vapour in the air per hour,
 h = total heat in the water vapour per hour,
 t_1 = temperature of the air in ° F.

Heat carried into the engine by dry air = $d \times V \times 0.24(t_1 - 32)$ B.Th.U.
 Heat carried in by vapour = $w \times h$ B.Th.U.

¹ *Proc. Inst. C.E.*, vol. clxiii., 1905-6, p. 241.

² See Report of Committee, *Proc. Inst. C.E.*, vol. clxiii., 1905-6, p. 241.

³ "The Measurement of Air Supply to Internal Combustion Engines by means of a Throttle Plate," by Professor W. Watson and H. Schofield, *Proc. I. Mech. E.*, 1912, p. 517.

The amount of water vapour present in the air is obtained from the dew point. The difference between the readings of the wet and dry bulb thermometers is taken together with the reading of the barometer. For example, if the difference between the readings of the wet and dry bulb thermometers is 3°F. , and the temperature of the dry bulb is 48.4°F. Glaisher's factor for this difference is 2.1 (p. 482); hence the dew point is

$$48.4 - (3 \times 2.1) = 42.1^{\circ}\text{F.}$$

From steam tables we find that the pressure of water vapour at 42.1°F. is 0.132 pound per square inch absolute. The reading of the barometer is, say, 29.69 inches $= 0.491 \times 29.69 = 14.58$ pounds per square inch absolute.

Now the barometric pressure is equal to the *sum* of the pressure of the water vapour and of the dry air, hence

pressure of dry air $= 14.58 - 0.13 = 14.45$ pounds per square inch absolute, and the volume of 1 pound of dry air is

$$\begin{aligned} v &= \frac{RT}{P} \quad (\text{Art. 4}) \\ &= \frac{53.18 \times (460 + 48.4)}{14.45 \times 144} = 13.02 \text{ cubic feet} \end{aligned}$$

Hence, at the dew point we have in each pound of air having a volume of 13.02 cubic feet, 13.02 cubic feet of water vapour at a pressure of 0.132 pound absolute. Since the specific volume of steam at this pressure is 2352 cubic feet per pound, it follows that the weight of steam entering the engine with each pound of air is

$$\frac{13.02}{2352} = 0.00554 \text{ pound}$$

The total heat of this weight of steam may be found from steam tables, but in order to save time the Committee on Internal Combustion Engines give a curve from which it may be read off directly.

Analysis of Exhaust Gases.—The gases may be collected and analysed as described in Art. 213, or the following method may be adopted. Dry the gas by bubbling it through concentrated sulphuric acid and then through a tube containing calcium chloride. Then pass the dry gas through a combustion tube filled with pure copper oxide, a calcium chloride tube, two bulbs containing caustic potash, and finally through another calcium chloride tube. The increase in weight of the first calcium chloride tube after the combustion tube gives the weight of steam in the exhaust gases taken, and the increase in weight of the two potash bulbs, and the last chloride tube gives the weight of CO_2 .

203. Heat brought in and carried away by the Jacket Water.—

Let W = weight of jacket water used per hour,

t_1 = inlet temperature in $^{\circ}\text{F.}$,

t_2 = outlet temperature in $^{\circ}\text{F.}$,

Then heat brought into the engine per hour = $W(t_1 - 32)$ B.Th.U.
 heat carried away from engine per hour = $W(t_2 - 32)$ B.Th.U.

204. Heat carried away by the Exhaust Gases.—This may be calculated approximately if the temperature of the exhaust gases is measured.

Let w_1 = weight of dry exhaust gases (in pounds) leaving the engine per hour,

w_2 = weight of steam (pounds) in the gases per hour,

t = temperature of exhaust gases in ° F.,

s = specific heat at constant pressure of dry exhaust gases, assumed constant,

L = latent heat of steam at the exhaust pressure in B.Th.U. per pound,

t_s = temperature of saturation of the steam at exhaust pressure.

Then w_1 = weight of dry air supplied + weight of dry gas supplied — weight of steam formed by combustion

and w_2 = weight of steam in air and gas supply + weight of steam formed by combustion

Heat carried away by exhaust per hour

$$= w_1 s(t - 32) + \{0.5(t - t_s) + (L + t_s - 32)\} w_2 \text{ B.Th.U.}$$

where 0.5 = specific heat of steam (assumed constant).

The heat rejected in the exhaust may be directly measured by using an exhaust gas calorimeter first introduced by Professor Hopkinson.¹ The calorimeter used by the Committee on the Efficiency of Internal Combustion Engines is shown in Fig. 158A. The calorimeter is directly con-

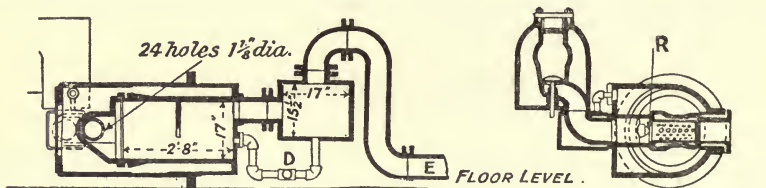

FIG. 158A.

nected to the exhaust flange on the engine. The gases come in contact with a jet of water issuing from the nozzle R, and the gas and water afterwards leave the calorimeter by the pipes E and D, respectively.

Let w_1 = weight of dry exhaust gases in pounds per hour,

w_3 = weight of steam in the gases leaving the calorimeter in pounds per hour,

t = temperature of gases leaving calorimeter in ° F.,

t_1 = inlet temperature of water to calorimeter in ° F.,

t_2 = outlet temperature of water from calorimeter in ° F.,

W = weight of water leaving calorimeter in pounds per hour,

s = specific heat at constant pressure of the exhaust gases,

L = latent heat of steam at temperature t ° F. in B.Th.U. per pound.

¹ Proc. I. Mech. E., 1908, p. 451.

The exhaust gases leaving the calorimeter are assumed saturated with water vapour, w_2 being estimated as explained on p. 348. Then

$$\left. \begin{array}{l} \text{Heat carried away from} \\ \text{calorimeter by exhaust} \\ \text{gases per hour} \end{array} \right\} = w_1 s(t - 32) + w_2(L + t - 32) \text{ B.Th.U.}$$

$$\left. \begin{array}{l} \text{Heat in water entering calori-} \\ \text{meter per hour} \end{array} \right\} = (W + w_3 - w_2)(t_1 - 32) \text{ B.Th.U.}$$

$$\left. \begin{array}{l} \text{Heat in water leaving calori-} \\ \text{meter per hour} \end{array} \right\} = W(t_2 - 32) \text{ B.Th.U.}$$

EXAMPLE.—The following data were obtained from a gas engine trial:—

Indicated horse-power, 82.

Volumetric analysis of gas: CO_2 11.2 per cent.; $\text{O}_2 = \text{nil.}$; CO 18.9; H_2 23.0 per cent.; CH_4 43.6 per cent.; N_2 43.3 per cent.

Calorific values of gas by Junker's calorimeter: higher value 181, lower 167 B.Th.U. per cubic foot.

Gas supplied per I.H.P. per hour at N.T.P., 38.45 cubic feet.

Barometer 751 mm. = 14.50 pounds per square inch.

Temperature of atmosphere, 78° F.; difference between wet and dry bulb thermometers, 2° F.

Temperature of gas supply, 72° F.

Weight of cooling water per hour, 2330 pounds.

Inlet temperature of cooling water, 78.5° F.

Outlet temperature of cooling water, 152° F.

Volumetric analysis of exhaust gases: CO_2 8.2 per cent.; O_2 11.2 per cent.; N 80.6 per cent.

Estimate:—

(a) Thermal efficiency of the engine, *i.e.* thermal equivalent of I.H.P.

(b) Heat carried into engine by air supply per hour.

(c) Heat carried into engine by gas supply per hour.

(d) Heat carried into engine by jacket water per hour.

(e) Heat carried away by jacket water per hour.

(f) Heat carried away by exhaust gases per hour.

(g) Heat unaccounted for per hour.

Total gas per hour = $38.45 \times 82 = 3153$ cubic feet at N.T.P.

(a) Heat of combustion per hour = $3153 \times 167 = 526,550$ B.Th.U.

Thermal equivalent of I.H.P. per hour = $2545 \times 82 = 208,690$ B.Th.U.

$$\therefore \text{thermal efficiency} = \frac{208,690}{526,550} = 0.396 \text{ or } 39.6 \text{ per cent.}$$

(b) From the analysis of the gas the minimum amount of air required for complete combustion is calculated as explained in Art. 143.

$$\begin{aligned} \text{Cubic feet of air per cubic feet of gas} &= 2.38 \times \text{H} + 9.52 \text{CH}_4 + 2.38 \text{CO} \\ &= 2.38 \times 0.23 + 9.52 \times 0.036 \\ &\quad + 2.38 \times 0.189 \\ &= 1.34 \text{ cubic feet.} \end{aligned}$$

Following the method of Art. 143, the products will consist of

CO ₂ from 0.036 cubic foot of CH ₄	0.036 cubic foot
" " 0.189 " " CO	0.189 " "
In the gas	0.112 " "
Total CO ₂	0.337 " "
H ₂ O from 0.23 cubic foot of H ₂	0.23 cubic foot
" " 0.036 " " CH ₄	0.072 " "
Total H ₂ O	0.302 " "
N ₂ from 1 cubic foot of gas	0.433 cubic foot
" 1.34 cubic feet of air = 1.34 × $\frac{79}{100}$ =	1.058 " "
Total N ₂	1.49 cubic feet

∴ volume of total products when the H₂O remains as steam
= 0.337 + 0.302 + 1.49 = 2.13 cubic feet

Now when the exhaust gases are analysed the steam is condensed.

∴ volume of products = 2.13 - 0.30 = 1.83 cubic feet

$$\begin{aligned} \text{Excess air supplied (cubic feet)} &= \frac{1.83 \times 11.2}{21 - 11.2} \text{ (by Art. 143)} \\ &= 2.09 \text{ cubic feet} \end{aligned}$$

∴ total dry air supplied per cubic foot of gas = 1.34 + 2.09 = 3.43 cubic feet.

The difference between wet and dry bulb thermometer is 2° F.; Glaisher's factor (p. 482) for this difference and a dry air temperature of 78° F. is 1.7.

$$\therefore \text{dew point} = 78 - 1.7 \times 2 = 74.6^\circ \text{ F.}$$

The pressure of steam at this temperature (74.6° F.) from tables is 0.42 pound per square inch absolute.

∴ pressure of dry air = 14.50 - 0.42 = 14.68 pounds per square inch absolute, and volume of 1 pound of dry air

$$= \frac{53.18 \times (78 + 460)}{14.08 \times 144} = 14.11 \text{ cubic feet}$$

Now, from steam tables we find that the specific volume of steam at 74.6° F. or 0.42 pound per square inch is 755 cubic feet per pound.

∴ weight of water vapour in 14.11 cubic feet of air

$$= \frac{14.11}{755} = 0.0186 \text{ pound}$$

Weight of dry air supplied per hour = $\frac{3.43 \times 3153}{14.11} = 766.5$ pounds

∴ weight of steam in this air = 766.5 × 0.0186 = 14.25 pounds

The total heat of one pound of steam at 74.6° F. (from tables) is 1104 B.Th.U.

$$\begin{aligned} \therefore \text{heat carried into engine per hour by steam in air supply} \\ &= 1104 \times 14.25 \\ &= 15,730 \text{ B.Th.U.} \end{aligned}$$

$$\begin{aligned} \text{and heat carried into engine by dry air per hour} \\ &= 766.5 \times 0.24(78 - 32) \\ &= 8460 \text{ B.Th.U.} \end{aligned}$$

$$\therefore \text{total heat carried into engine per hour by the air supply} \\ = 15,730 + 8460 = 24,190 \text{ B.Th.U.}$$

(c) To find the heat carried into the engine by the gas supply we must first find the specific heat of the gas and its weight, as follows:—

Volumetric analysis of gas (per cent.).	Weight per cub. ft. at N.T.P. (pounds).	Weight per 100 cub. ft. of gas (pounds).	C_p .	Heat for a rise of 1° F. per 100 cub. ft. of gas.
CH ₄ = 3.6	0.0455	0.1638	0.593	0.0971
H ₂ = 23.0	0.00559	0.1286	3.409	0.4383
CO = 18.9	0.0773	1.4609	0.245	0.3579
CO ₂ = 11.2	0.1238	1.3865	0.216	0.2995
N ₂ = 43.3	0.0788	3.4120	0.244	0.8325
Total weight . . . 6.5518			Total . . . 2.0253	

$$\therefore \text{density of the gas at N.T.P.} = 0.0655 \text{ pound per cubic foot}$$

$$\text{and specific heat at constant pressure} = \frac{2.0253}{6.5518} = 0.309$$

$$\begin{aligned} \therefore \text{heat carried into engine by gas} \\ \text{supply per hour} \end{aligned} \left. \vphantom{\begin{aligned} \therefore \text{heat carried into engine by gas} \\ \text{supply per hour} \end{aligned}} \right\} = 3153 \times 0.0655(72 - 32) \\ = 206.5 \times 40 \\ = 8260 \text{ B.Th.U.}$$

$$\begin{aligned} (d) \text{ Heat carried into engine by jacket} \\ \text{water per hour} \end{aligned} \left. \vphantom{\begin{aligned} (d) \text{ Heat carried into engine by jacket} \\ \text{water per hour} \end{aligned}} \right\} = 2330(78.5 - 32) \\ = 109,345 \text{ B.Th.U.}$$

$$\begin{aligned} (e) \text{ Heat carried away by jacket water} \\ \text{per hour} \end{aligned} \left. \vphantom{\begin{aligned} (e) \text{ Heat carried away by jacket water} \\ \text{per hour} \end{aligned}} \right\} = 2330(152 - 32) \\ = 279,600 \text{ B.Th.U.}$$

(f) Heat carried away by exhaust gases per hour.—The weight of steam formed by combustion has been estimated above to be 0.302 cubic foot per cubic foot of gas.

$$\begin{aligned} \therefore \text{weight of steam from 1 cubic foot of gas (by Art. 149)} \\ = 0.302 \times 0.00559 \times 9 = 0.0152 \text{ pound} \end{aligned}$$

$$\therefore \text{total steam per hour} = 0.0152 \times 3153 = 48 \text{ pounds}$$

$$\begin{aligned} \text{and weight of dry exhaust gases per hour (Art. 204)} \\ = 766.5 \div 206.5 - 48 = 92.5 \text{ pounds} \end{aligned}$$

$$\begin{aligned} \text{Total weight of steam in the exhaust gases} \\ \text{per hour} \end{aligned} \left. \vphantom{\begin{aligned} \text{Total weight of steam in the exhaust gases} \\ \text{per hour} \end{aligned}} \right\} = 14.25 + 48 \text{ (Art. 204)} \\ = 62.25 \text{ pounds}$$

∴ heat carried away in exhaust gases per hour, assuming them to be at atmospheric pressure (Art. 204)

$$\begin{aligned} &= 925 \times 0.25 \times (1032 - 32) + \{0.5(1032 - 212) \\ &\quad + 966 + 212 - 32\}62.25 \\ &= 231,250 + 102,460 \\ &= 333,710 \text{ B.Th.U.} \end{aligned}$$

The heat account for this engine trial may therefore be made out as follows:—

Heat brought in per hour above 32° F., B.Th.U.

By combustion of gas (lower value)	526,550
„ moisture in air supply	15,730
„ dry air	8,460
„ entering gas	8,260
„ jacket water supply	109,345
Total	<u>668,345</u>

Heat carried away per hour above 32° F., B.Th.U.

By dry exhaust gases	231,250
„ steam in exhaust gases	102,460
„ jacket water	279,600
Unaccounted for, radiation, errors of observation, etc.	<u>55,035</u>
Total	<u>668,345</u>

EXAMPLES XVI

1. The following particulars were obtained from a trial of a four-stroke cycle oil engine:—

Duration of trial, 40 minutes; oil used, 12.80 lbs.; total revolutions, 8142; jacket water, 738 lbs.; rise of temperature of jacket water, 74° F.; mean effective pressure in cylinder, 96 lbs. per square inch; torque due to brake load, 786 lbs.-feet; lower calorific value of oil, 17,000 B.Th.U. per lb.; area of piston, 113 square inches; stroke, 18½ inches.

Find (a) the indicated and brake horse-powers; (b) the oil used per I.H.P. and per B.H.P. per hour; (c) the heat converted into indicated work per minute; (d) the heat rejected by the jacket water per minute; (e) the heat lost by friction, exhaust gases, etc., per minute.

2. In a test on an oil engine running at half full load on Russolene the oil used was 6.8 lbs. per hour, the I.H.P. was 8.33, jacket water, 935 lbs. per hour, and its rise of temperature, 67.4° F. The total air sent into the engine per hour was 301.8 lbs. The exhaust gases per hour consisted of 21.4 lbs. of CO₂, 8.05 lbs. of H₂O, and 279.15 lbs. of air. The temperature of the air in the engine-room was 51° F., and of the exhaust gases 531° F. The lower calorific value of the oil was 18,000 B.Th.U. per lb. Calculate:—

(a) Heat converted into work per hour; (b) heat rejected in jacket water per hour; (c) heat rejected in exhaust gases per hour; (d) heat unaccounted for per hour. *Given.* Specific heat of CO₂ = 0.216, of H₂O = 0.480, of air 0.238.

3. The following particulars were obtained from trials of a four-stroke cycle oil engine: Cylinder diameter, 12 inches; stroke, 18½ inches; dia. of brake wheel,

CHAPTER XVII

STEAM ENGINE AND BOILER TRIALS

205. Steam Engine Trials.—In commercial tests it is generally sufficient to measure the steam consumption per I.H.P. or per B.H.P. hour, but for a complete thermodynamic trial it is necessary to measure the losses in addition, and also to draw up a heat account. The measurements necessary to determine the thermal efficiency and to draw up the heat account are :—

1. Indicated horse-power.
2. Brake horse-power (if possible).
3. Rate of steam supply by weight, *i.e.* pounds of steam per hour.
4. Dryness fraction of the steam on the boiler side of the engine stop valve.

Or *4a.* Temperature of the steam if superheated steam is used.

5. Pressure of the steam at the engine stop valve.
6. Temperature (or pressure) of the exhaust steam.

206. Indicated Horse-power.—When proper precautions are taken it is possible to estimate the I.H.P. of a steam engine with great accuracy. It is essential for accurate results that the pressure inside the indicator cylinder should be the same as the pressure inside the engine cylinder at all points of the stroke, otherwise the diagram will not be a true representation of the variation in pressure on the engine piston. In order to ensure this, the connecting pipe between the indicator and engine cylinder should be as short and straight as possible and of large bore. The indicator should also be fixed vertically to reduce the possibility of water lodging in the indicator cylinder and connecting pipe. In the case of double-acting engines a separate indicator should be used for each end of the cylinder, and before taking a diagram the steam should be allowed to blow freely through in order to clear out as much as possible of the water which may have collected in the pipes.

Considerable errors will result in the estimated mean pressure if the motion of the indicator drum be not a true representation of the motion of the engine piston. For this reason an accurate reducing motion should be used,¹ and the spring inside the drum should be sufficiently strong to prevent any backlash. The indicator spring should be tested for accuracy when under steam by direct comparison with a mercury column.

When taking a diagram steam should be first blown through for about

¹ See "Testing of Motive Power Engines," Royds. Longmans, Green, & Co.

one minute, then the indicator cord coupled up to the reducing gear and the diagram taken, the pencil being pressed *lightly* against the paper for about twenty seconds. The atmospheric line should then be drawn and the indicator cord uncoupled; the diagram may then be measured up for mean pressure by means of a planimeter or by the method of mean ordinates. The indicated horse-power is then calculated in the usual way.

Let d_1 = diameter of engine cylinder in inches.

d_2 = " " piston rod "

p_1 = mean effective pressure on the head end of the piston in pounds per square inch.

p_2 = mean effective pressure on the crank end of the piston in pounds per square inch.

l = stroke in feet.

n = revolutions per minute.

Then the indicated horse-power will be

$$\text{On the head end I.H.P.} = \frac{p_1 \times \frac{\pi d_1^2}{4} \times l \times n}{33,000} \dots (1)$$

On the crank end of the piston the effective area will be

$$\frac{\pi}{4}(d_1^2 - d_2^2)$$

and the I.H.P. developed on the crank end will be

$$\frac{p_2 \times \frac{\pi}{4}(d_1^2 - d_2^2) \times l \times n}{33,000} \dots (2)$$

The total I.H.P. will evidently be the sum of the above two quantities. Instead of working out the I.H.P. on each side of the piston and then adding them together, the total I.H.P. can be calculated directly as follows:—

$$\begin{aligned} \text{Average area of piston (both sides) } A &= \frac{\frac{\pi d_1^2}{4} + \frac{\pi}{4}(d_1^2 - d_2^2)}{2} \\ &= \frac{\pi}{8}(2d_1^2 - d_2^2) \text{ square inches} \end{aligned}$$

The average mean pressure (both sides) $p_m = \frac{p_1 + p_2}{2}$ pounds per sq. in.

$$\therefore \text{total I.H.P.} = \frac{p_m \times A \times l \times 2n}{33,000} \dots (3)$$

When a single indicator is used for indicating both ends of a cylinder the mean pressure is best obtained by using a planimeter, and starting where the two expansion lines intersect, the tracing point is run round one diagram in a clockwise direction, and then round the other diagram. The difference between the initial and final readings of the planimeter divided by two and multiplied by the strength of the spring will then give

the average mean pressure on the two sides of the piston. Equation (3) may then be used directly and the total I.H.P. calculated directly. If a large number of tests are to be made on any engine a great saving of time will result if the "indicated horse-power constant" is calculated once and for all.

In any engine A and l are constants, and the factor

$$\frac{2Al}{33,000}$$

in equation (3) is known as the indicated horse-power constant. If c denotes this constant, then

$$\text{Total I.H.P.} = c \times p_m \times n \dots \dots \dots (4)$$

207. Brake Horse-power.—The type of dynamometer which should be used will depend upon the size of the engine under test. For comparatively small powers (up to say 400 B.H.P.) an ordinary rope brake may be used with success (Fig. 158), but for large powers several alternatives are possible. A very convenient method is to couple the engine up directly to a dynamo whose efficiency is known at all loads. The output from the dynamo is very easily measured and the B.H.P. of the engine calculated.

Let I = current from the dynamo in amperes.

V = voltage or *p.d.* at the dynamo terminals.

E = efficiency of the dynamo at this load.

Then
$$\text{B.H.P. of engine} = \frac{I \times V}{746E} \dots \dots \dots (1)$$

If a dynamo is not available and the power is too large to be measured by a rope brake, a hydraulic brake may be used,¹ whilst for large engines (marine engines) a torsion meter may be used.

In the latter apparatus the angle of twist over a certain length of the propeller shaft is measured, from which the shaft horse-power can be calculated as follows:—

Let θ = angle of twist in *radians* measured over a length l inches of the shaft.

N = modulus of rigidity of the shaft in pounds per square inch (12,000,000 for steel).

J = polar moment of inertia of the shaft.

n = revolutions of the shaft per minute.

Then the twisting moment transmitted by the shaft is—

$$\begin{aligned} T &= NJ \frac{\theta}{l} \text{ pound-inches} \\ &= \frac{NJ\theta}{12l} \text{ pound-feet} \dots \dots \dots (2) \end{aligned}$$

and the shaft horse-power =
$$\frac{T \times 2\pi n}{33,000} \dots \dots \dots (3)$$

¹ For a detailed description see "The Testing of Motive Power Engines," by R. Royds. Longmans, Green, & Co.

INDICATED HORSE-POWER.

Time.	Indicator diagram.		Mean effective pressure.			Remarks.
	No.	Taken by.	H.P. cylinder.	I.P. cylinder.	L.P. cylinder.	

BRAKE OR ELECTRICAL HORSE-POWER.

Time.	Spring balance.	Load on brake.	Revolution counter.	Amperes.	Volts.	Remarks.

The engine should be run under trial load for some time before the commencement of the trial in order that everything may get settled down into the steady working condition required. On the completion of the trial the necessary data should be averaged up and a heat account drawn up as follows :—

	B.Th.U.	Per cent.
Gross heat supply entering engine per minute		100·0
Heat equivalent of I.H.P. per minute		
Heat leaving engine in jacket drain per minute		
Heat leaving engine in exhaust steam per minute		
Unaccounted for, radiation, errors of observation, etc.		
Total		100·0

EXAMPLE.—The following particulars were obtained from a trial on a triple-expansion steam engine :—

Weight of steam used per hour (air pump discharge)	10,013 lbs.
Weight of steam used per hour in jackets	1240 lbs.
Temperature of jacket drainage	368·5° F.
Steam pressure at boiler side of stop valve	170 lbs. per square inch absolute
Dryness fraction at boiler side of stop valve	0·930
Temperature of exhaust (estimated from indicator diagrams)	170° F.
Total I.H.P.	700
Weight of circulating water per minute	5000 lbs.
Rise of temperature of circulating water	30° F.
Temperature of air pump discharge (hot well temperature)	110° F.

Draw up a heat account for this engine, and in addition calculate—

- (a) Steam consumption per I.H.P. hour.
- (b) Thermal efficiency of the engine.
- (c) Ideal thermal efficiency if the engine worked on the Rankine cycle.
- (d) Efficiency ratio, or coefficient of performance.

Gross Heat Supply entering Engine per Minute.

$$\text{Total steam supplied per minute} = \frac{10,013 + 1240}{60} = 187.5 \text{ pounds.}$$

From steam tables (p. 481) we find that at 170 pounds absolute the sensible heat per pound is 340.7 B.Th.U., and the latent heat is 854.7 B.Th.U. Hence the total heat per pound of steam admitted is

$$340.7 + 0.93 \times 854.7 = 340.7 + 794.8 = 1135.5 \text{ B.Th.U.}$$

$$\therefore \text{gross heat supply per minute} = 1135.5 \times 187.5 = 212,896 \text{ B.Th.U.}$$

Heat Equivalent of I.H.P. per Minute.

$$\text{One horse-power per minute} = \frac{33,000}{778} = 42.41 \text{ B.Th.U.}$$

$$\therefore \text{heat equivalent} = 42.41 \times 700 = 29,687 \text{ B.Th.U.}$$

Heat leaving Engine in Jacket Drain per Minute.—The weight of jacket steam condensed and drained away per minute = $\frac{1240}{60} = 20.7$ pounds.

$$\therefore \text{heat leaving per minute} = 20.7(368.5 - 32) = 6965 \text{ B.Th.U.}$$

Heat leaving Engine in Exhaust Steam per Minute.—This item will be (weight of condensing water per minute) \times (rise of temperature of condensing water) + (weight of condensed steam leaving the engine per minute) \times (hot-well temperature — 32° F.)

$$\begin{aligned} &= 5000 \times 30 + \frac{10,013}{60} (110 - 32) \\ &= 150,000 + 13,017 \\ &= 163,017 \text{ B.Th.U.} \end{aligned}$$

The heat account will therefore be made up as follows:—

	B.Th.U.	Per cent.
Gross heat supply entering engine per minute . . .	212,396	100.0
Heat equivalent of I.H.P. per minute	29,687	13.94
Heat leaving engine in jacket drain per minute . . .	6,965	3.30
Heat leaving engine in exhaust steam per minute . . .	163,017	76.56
Unaccounted for, radiation, errors of observation, etc. .	13,227	6.30
Total	212,896	100.00

$$(a) \text{ Steam consumption per I.H.P. hour} = \frac{10,013 + 1240}{700} = 16.07 \text{ lbs.}$$

(b) Thermal efficiency. The heat supplied to a steam engine is calculated as "the total heat of the steam entering the engine less the water heat of the same weight of water at the temperature of the exhaust, both quantities being reckoned from 32° F.

In the above example the steam per hour per I.H.P. has been found to be 16.07 pounds, and since the exhaust temperature is given as 170° F., we have

$$\begin{aligned} \text{Heat supplied per minute per I.H.P.} &= \frac{16.07}{60} \times 1135.5 - \frac{16.07}{60} (170 - 32) \\ &= 0.268(1135.5 - 170 + 32) \\ &= 267.33 \text{ B.Th.U.} \end{aligned}$$

$$\therefore \text{thermal efficiency} = \frac{42.41}{267.33} = 0.158, \text{ or } 15.8 \text{ per cent.}$$

$$\begin{aligned} (c) \text{ The Rankine } \left. \begin{array}{l} \text{cycle efficiency} \end{array} \right\} &= \frac{(T_1 - T_2) \left(1 + \frac{x_1 L_1}{T_1} \right) - T_2 \log_{\epsilon} \frac{T_1}{T_2}}{x_1 L_1 + T_1 - T_2} \quad (\text{Art. 57, (6)}) \\ &= \frac{(828.5 - 630) \left(1 + \frac{0.93 \times 854.7}{828.5} \right) - 630 \log_{\epsilon} \frac{828.5}{620}}{0.93 \times 854.7 + 828.5 - 630} \\ &= \frac{198.5 \times 1.959 - 172.6}{993.3} \\ &= \frac{216.2}{993.3} = 0.217, \text{ or } 21.7 \text{ per cent.} \end{aligned}$$

$$\begin{aligned} (d) \text{ Coefficient of } \left. \begin{array}{l} \text{performance} \end{array} \right\} &= \frac{\text{actual thermal efficiency}}{\text{Rankine efficiency}} \\ &= \frac{0.158}{0.217} = 0.72 \end{aligned}$$

210. Steam Boiler Trials.—The measurements necessary to determine the thermal efficiency and to draw up the heat account for a boiler are:—

1. Rate of fuel consumption, *i.e.* pounds of fuel per hour.
2. Sampling of the fuel and determination of its calorific value and chemical analysis.
3. Rate of water evaporation, *i.e.* pounds per hour.
4. Steam pressure.
5. Dryness fraction of the steam; or
- 5A. The temperature of the steam if there is a superheater.
6. Feed temperature.
7. Temperature and analysis of flue gases.
8. Sampling and weighing of ashes and the determination of their calorific value.
9. Measurement of the air pressure, temperature, and humidity.

With the exception of the humidity of the air supply, a detailed description of the best methods of making the above measurements will be found

in the Report of the Committee of the Institution of Civil Engineers on Steam Engine and Boiler Trials.¹

To obtain the best results from a steam boiler on trial, special attention must be paid to stoking, particularly if the boiler is hand fired. The method of starting and stopping the trial and the duration of the trial are also of great importance.

The best method to adopt must be decided on the spot by the principal observer, and will depend entirely upon the conditions under which the boiler has to work. The following method will generally be found the most convenient.

The boiler having been under load for some time in order to get settled down into working condition, about fifteen minutes before the trial commences, the fire should be cleaned and all ashes and clinker removed, the thickness of the fire, the pressure-gauge, and the temperature of the flue gases being carefully watched. The instant the pressure shows a decided tendency to fall should be taken as the time of commencement. The thickness of the fire, the steam pressure, and the temperature of the flue gases should immediately be noted, the water-level marked by tying a piece of string round the gauge glass, and the feed pump stopped. At the end of the trial, the thickness of the fire, the steam pressure, and the temperature of the flue gases should be the same as at the start. It will save time in working out the results if the water-level in the feed tank and gauge-glass is the same at the conclusion as at the commencement of the trial.

The things that should be brought to the same state at the beginning and end of the trial are : (1) the quantity of heat stored in the brickwork ; (2) the quantity of heat stored in the economiser, if one is fitted ; (3) the steam pressure, approximately ; (4) the rate of evaporation per unit of time, since the height of the water in the gauge-glass is thereby materially affected, being always higher (often one inch higher) when the boiler is giving off its full supply of steam than when the evaporation has nearly ceased.

The duration of the trial will depend chiefly upon the magnitude of the error likely to be made in judging the thickness and condition of the fires at the beginning and end of the trial as compared with the weight of fuel stoked during the trial. This judgment should therefore be made by the principal observer. The time should not, as a rule, be less than six hours.

211. Rate of Fuel Consumption and Determination of its Calorific Value.—The fuel should be weighed out in convenient lots of from 20 to 200 pounds, depending upon the size of the boiler, using two boxes for the purpose. At the time of commencement of the trial the first lot should be emptied out on to the floor and stoking commenced. The record may be conveniently kept on a log-sheet, as follows :—

Time of emptying No. 1 box on stoke- hold floor.	Time of emptying No. 2 box on stoke- hold floor.	Time interval, minutes.	Remarks.
9.5	—	—	
—	9.15	10	
9.24	—	9	
—	9.36	12	

¹ *Proc. Inst. C. E.*, vol. cl., p. 218. The report may also be obtained separately from Messrs. W. Clowes & Sons, Ltd., Duke Street, Stamford Street, S.E., and must be referred to for the full instructions. See also the Author's book on "Steam Boilers" (Edward Arnold).

While the trial is proceeding the fuel consumption should be plotted on a time base. The weight of coal in a given charge should be plotted, not over the time when it is fired, but over the time of firing the first shovelful of the next charge; by this means a careful check is kept upon the observations and any error immediately detected.

A sample should be taken from every lot of fuel weighed out and towards the end of the trial the samples should be broken up into small pieces, well mixed up, and about two pounds taken for analysis and for the determination of its calorific value in the Bomb calorimeter. An expert chemist should analyse the fuel for carbon, hydrogen, sulphur, ash, moisture, etc. At the end of the trial the ashes and clinker should be weighed and a sample of the ashes taken for the determination of their calorific value.

212. Rate of Water Evaporation.—Some system of volumetric measurement is invariably used for measuring the feed water supplied to the boiler. Various methods may be arranged for this purpose. When large quantities of water are to be dealt with, two measuring tanks may be used, each fitted with a gauge-glass and accurately calibrated at, say, 60° F. The cylindrical cooling water-tanks usually used for gas engines are convenient for this purpose, being calibrated up to 5000 pounds. The Author has used two such tanks with great success, the total fall in level resulting from the withdrawal of 5000 pounds of water being about 6 feet; the level in the calibrated gauge-glass could be read accurately to within $\frac{1}{8}$ inch, so that the total maximum error possible with each tank full would be $\frac{1}{4}$ inch, and the maximum possible error negligibly small. The tanks may be used as follows:—

Before the commencement of the trial No. 1 tank should be filled up, the boiler being fed from No. 2 tank at the rate intended for the trial. Just before the trial commences the feed-pump should be stopped and the water-level in the feed-tank (if one is used) marked and recorded. When the trial commences the feed-pump is started again, the boiler being fed from No. 1 tank whilst No. 2 is being filled up. The record may conveniently be kept on the following log-sheet, the observations being continuously checked by plotting the water supplied on a time base as described for the fuel.

Time of starting No. 1 tank.	Reading of gauge glass on No. 1.	Time of starting No. 2 tank.	Reading of gauge glass on No. 2.	Temperature of water in tanks.	Time interval, minutes.	Remarks.
9.1	0	—	—	58	—	
—	5000	9.21	0	59	20	
9.42	0	—	—	58	21	
—	5000	10.2	0	59	20	

If the temperature of the water in the measuring tanks differs appreciably from the temperature at which the tanks were calibrated, a correction must be made when estimating the weight of feed water supplied to the boiler. The boiler (or boilers) under test should be “blanked off” from all others so that the measured feed water only enters the boiler under test.

213. Temperature and Analysis of the Flue Gases.—Mercury in glass thermometers previously calibrated should be used to measure

low temperatures, but the temperature of the flue gases or of superheated steam is most accurately measured by an electrical method.¹ The samples should be taken just on the chimney side of the damper at the same place at which the temperature is measured. When the boiler under test is fired by mechanical stokers, the gas samples may be drawn directly into the analysing apparatus; but when the firing is by hand, continuous collection is necessary to secure an average sample. When great accuracy is required the flue gases should be collected over mercury, but distilled water which has been saturated with common salt, or water with a layer of oil on the top, will give results accurate enough for most purposes.

A convenient arrangement for the continuous collection of flue gases is shown in Fig. 159. An iron or glass tube, T, of about $\frac{1}{4}$ inch bore,

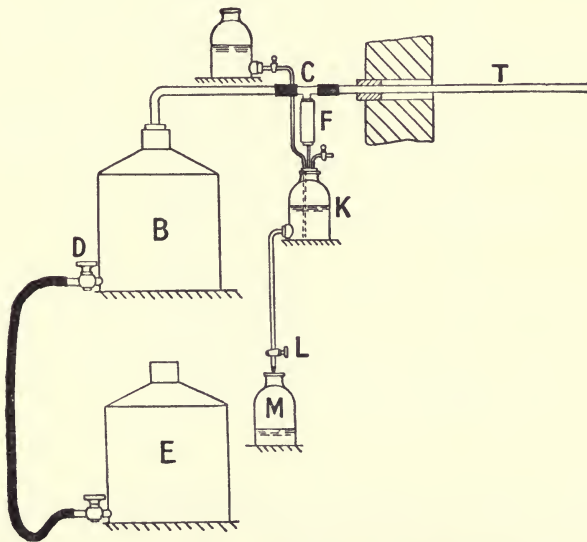

FIG. 159.

(From Royds' "Testing of Motive Power Engines.")

is inserted into the flue so that the end lies well in the current of the gases, and is connected up to the large water-bottle B by means of a glass tube, the rubber connections being made as short as possible. The bottom of the vessel B is connected by rubber tubing to the aspirator E open to the atmosphere, the rate of flow of the water from B to E being regulated by the cock D. These vessels are used to create a flow of gases through the tube T to the sample bottle K. The sample is drawn through a filter of cotton-wool F in order to prevent soot or ash from passing into the bottle. The rate of flow of mercury (or brine) from the bottle K is controlled by the cock L, so as to allow a sufficient quantity of gas to be collected during the test.

The gas is conveniently analysed on the spot in the Orsat apparatus

¹ See "The Testing of Motive Power Engines," R. Royds. Longmans, Green, & Co.

shown in Fig. 160. A is a eudiometer graduated up to 100 cubic centimetres, and surrounded by a water jacket to ensure a uniform temperature for all the gas measurements. B, B₁ and B₂ are flasks containing solutions of caustic soda, pyrogallic acid and cuprous chloride respectively, for the

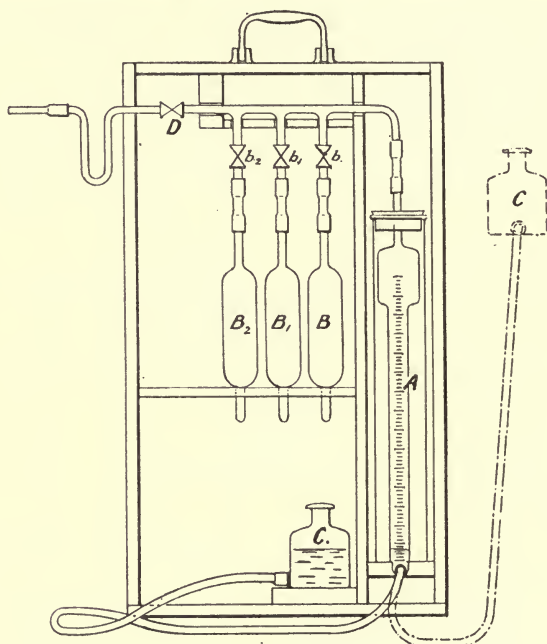

FIG. 160.

absorption of CO₂, O₂ and CO. These solutions may be made as follows:—

For CO₂ (in flask B).—One part of caustic soda (NaOH) to two of water by weight. Caustic potash (KOH) may be used instead of NaOH if desired.

For Oxygen (in flask B₁).—One part by weight of pyrogallic acid dissolved in 3 parts of water and 24 parts of either caustic soda or caustic potash dissolved in 16 parts of water. Sticks of phosphorus may be used instead of this alkaline pyrogallic if desired, although it is slower in its action.

For CO (in flask B₂).—A solution of cuprous chloride in hydrochloric acid, made by dissolving copper oxide (CuO) in about 20 times its weight of strong hydrochloric acid (HCl), and allowing it to stand in a rubber-corked bottle containing copper wire until the solution becomes colourless.

These reagent flasks contain a number of glass tubes packed together and open at the ends; by this means a large surface of reagent is exposed to the gas as it is driven over into the flask from A. Duplicate flasks are arranged behind the reagent flasks B, B₁ and B₂ for the reception of the reagents, as they are expelled from those flasks with which each

duplicate flask is respectively connected. C is an aspirator and D a three-way cock making a straight-through connection, and also a connection with the atmosphere when desired.

The gas to be analysed is drawn into A through the cock D and its volume read off, taking care that when doing so the water level in A is the same as in C. The bottle C is then raised, *b* opened and the gas driven over into B. The reagent in B is brought back again to its original level by lowering C, after which *b* is closed. This operation is repeated until all the CO₂ is removed.

The oxygen is absorbed in B₁ in the same way, and finally the CO (if any is present) in flask B₂. The apparatus will not give the percentage of CO accurately, but is sensitive enough to detect its presence. If the Orsat apparatus shows an appreciable amount of CO to be present, the gas should be analysed by a chemist. The amount of CO₂ and O₂ present can be determined to within 0.5 per cent., and if it is found when these two constituents are completely removed, that the residual nitrogen is 81 or 82 per cent. of the whole, then it may be conjectured that CO is present.

214. Efficiency and Heat Account of a Boiler.—The efficiency of a boiler is expressed by the fraction

$$\frac{\text{Heat put into the steam per pound of fuel fired}}{\text{Available heat in 1 pound of the fuel as fired}}$$

The available heat in one pound of the fuel as fired will not be the calorific value of one pound of dry fuel, unless of course the fuel as fired is dry. The moisture present in the fuel has to be evaporated and superheated to the temperature of the flue gases, and the amount of heat so utilised is lost. The effect of a moist air supply may also have an appreciable effect on the performance of a boiler, since on a wet or foggy day a considerable amount of moisture is carried into the furnace for every pound of fuel burned, and this moisture has to be heated, evaporated and superheated, the heat so expended being unavoidably lost in the flue gases. Even although no *water* may be carried into the furnace with the air supply, water vapour will be present, the amount of which may be estimated from the readings of the wet and dry bulb thermometers as explained in Art. 202. It will usually be found that the heat absorbed in superheating the water vapour in the air per pound of fuel is negligibly small and may be neglected. (See the Example worked out on p. 368.)

The actual available amount of heat supplied to the boiler per pound of fuel will therefore be—

Lower calorific value of dry coal in 1 pound of the coal as fired — heat absorbed by the moisture in the fuel as fired — heat absorbed by the moisture in the air supply.

In the Report of the Committee of the Institution of Civil Engineers on Steam Engine and Boiler Trials the effect of the moist air supply is neglected altogether, and in drawing up the heat account they recommend the following items, in which it will be seen that the heat lost in evaporating and superheating the moisture in the fuel is placed on the debit side.

	B.Th.U.	Per cent.
1. Total heat value of one pound of dried fuel		
2. Heat transferred to the water (<i>thermal efficiency</i>)		
3. Heat carried away by products of combustion		
4. Heat carried away by excess air		
5. Heat lost in evaporating and in superheating the moisture mixed with the fuel		
6. Heat lost by incomplete combustion		
7. Heat lost by unburnt carbon in ash		
8. Balance of heat account :—Errors of observation and unmeasured losses such as those due to radiation, escape of unburnt hydrocarbons, superheating moisture in air, loss in hot ashes, etc.		
Total		

The effect of transferring the heat losses due to moisture in the fuel, and in the air supply from the debit to the credit side of the heat balance is to raise the efficiency slightly, and although for practical purposes the difference may be considered very small, this hardly by itself furnishes sufficient reason for adopting a method which is not strictly correct in principles.

EXAMPLE.—Draw up the heat account from the following data obtained from a boiler trial :—

Feed water per hour	18,090 lbs.
Coal per hour (wet as fired)	2210 lbs.
Moisture in 1 pound of coal as fired	9 per cent.
Lower calorific value per pound of dry coal	14,890 B.Th.U.
Analysis of dry coal by weight per cent.	C 84, H 5·48, ash 3
Analysis of flue gases by volume per cent. CO ₂ 8·20, O ₂ 11·27, N ₂ 80·60	
Average steam pressure (pounds per square inch absolute)	210
Superheated steam temperature	490° F.
Temperature of feed to boiler	219° F.
Temperature of boiler house	55° F.
Temperature of flue gases leaving boiler	455° F.
Difference between wet and dry bulb thermometers in boiler house	2° F.
Barometric pressure (pounds per square inch absolute)	14·6

The heat account as recommended by the Committee of the Institution of Civil Engineers may be drawn up as follows :—

Heat transferred to the Water.—The weight of *dry* coal burned per hour is 2210 — 2210 × 0·09 = 2010 pounds.

$$\text{Weight of steam per pound of dry coal} = \frac{18,090}{2010} = 9 \text{ pounds}$$

From steam tables (p. 480) the total heat per pound of dry saturated steam is 1199 B.Th.U., hence, assuming the specific heat to be 0·5, the total heat per pound will be

$$1199 + 0·5(491 - 386) = 1251 \text{ B.Th.U.}$$

$$\text{Hence the heat transferred to the water per lb. of dry coal} = 9 \times 1251 = 11,259 \text{ B.Th.U.}$$

Heat carried away by Products of Combustion and by Excess Air.—The method of calculating these quantities has been explained in detail in Art. 146. Following the method there given the weight of the products of combustion is found to be 12·6 pounds, and their mean specific heat 0·246, hence

$$\begin{aligned} \text{heat carried away by products of combustion} &= 12\cdot6 \times 0\cdot246(453 - 55) \\ &= 1240 \text{ B.Th.U.} \end{aligned}$$

The weight of excess air supplied per pound of dry coal is found to be 13·35 pounds, hence, taking the mean specific heat of air to be 0·238,

$$\begin{aligned} \text{heat carried away by excess air} &= 13\cdot35 \times 0\cdot238(455 - 55) \\ &= 1271 \text{ B.Th.U.} \end{aligned}$$

Heat lost in Evaporating and Superheating the Moisture in the Coal.—This item will be

$$\begin{aligned} &0\cdot09\{212 - 55 + 970 + 0\cdot5(455 - 212)\} \\ &= 0\cdot09\{157 + 970 + 121\} \\ &= 112 \text{ B.Th.U.} \end{aligned}$$

The heat balance will therefore be:—

	B.Th.U.	Per cent.
1. Total heat value of one pound of dried fuel	14,890	100·0
2. Heat transferred to water (thermal efficiency)	11,259	75·62
3. Heat carried away by products of combustion	1,240	8·33
4. Heat carried away by excess air	1,271	8 54
5. Heat lost in evaporating and in superheating moisture mixed with the fuel	112	0·74
6. Heat lost by incomplete combustion	—	—
7. Heat lost by unburnt carbon in ash	—	—
8. Unaccounted for	1,008	6·77
Total	14,890	100·00

It will be interesting to see what the efficiency of the above boiler would be if calculated on the available heat in 1 pound of the coal as fired. We have—

$$\text{Water evaporated per pound of coal as fired} = \frac{18,090}{2210} = 8\cdot19 \text{ pounds}$$

$$\therefore \text{heat transferred to water} = 8\cdot19 \times 1251 = 10,256 \text{ B.Th.U.}$$

The heat available in 1 pound of the coal (neglecting the moist air supply) will be—

Heat units of dry coal in 1 lb. of coal as fired — heat absorbed by moisture

$$\begin{aligned} &0\cdot91 \times 14,890 - 112 \\ &= 13,550 - 112 = 13,438 \text{ B.Th.U.} \end{aligned}$$

$$\therefore \text{efficiency of boiler} = \frac{10,256}{13,438} = 0\cdot7632, \text{ or } 76\cdot32$$

When based on *dry* coal the efficiency is 75·62, *i.e.* 0·70 per cent. *less.*

Effect of Water Vapour in the Air Supply.—Following the method explained in Art. 202 we have, since the difference between wet and dry bulb thermometers is 2° —

Glaisher's factor for an air temperature of 55° F. (p. 482) = 2 .

$$\therefore \text{dew point} = 55 - 2 \times 2 = 51^{\circ} \text{ F.}$$

The pressure of steam at 51° F. (from tables) = 0.185 pound per square inch absolute.

\therefore pressure of dry air = $14.7 - 0.185 = 14.515$ pounds absolute.

Volume of 1 pound of dry air at this pressure and temperature

$$\begin{aligned} &= \frac{53.18 \times (55 + 460)}{14.515 \times 144} \\ &= 13.10 \text{ cubic feet} \end{aligned}$$

The density of steam at 51° F. (from tables) is 0.000608 pound per cubic foot, hence—

Weight of water vapour in 1 pound of air occupying 13.10 cubic feet
 $= 13.10 \times 0.000608 = 0.008$ pound.

Now 25 pounds of air are supplied per pound of coal, hence the total weight of water vapour carried into the furnace by the air supply per pound of coal will be—

$$25 \times 0.008 = 0.2 \text{ pound}$$

The heat required to superheat this from 55° F. up to 455° F. will be—

$$0.2 \{0.5 \times (455 - 55)\} = 40 \text{ B.Th.U.}$$

Hence, the total heat available in 1 pound of the fuel as fired is

heat units of dry coal in 1 lb. of coal as fired — heat absorbed by moisture in coal — heat absorbed by vapour in air supply

$$\begin{aligned} &= 0.9 \times 14,890 - 112 - 40 \\ &= 13,550 - 152 = 13,400 \text{ B.Th.U.} \end{aligned}$$

and efficiency of boiler = $\frac{10,256}{13,400} = 0.7653$, or 76.53 per cent.

From the above it will be seen that in this particular case the actual efficiency of the boiler is 76.53 per cent., or 1 per cent. higher than that obtained when the heat balance is drawn up on the total heat in 1 pound of dry fuel. Neglecting the water vapour in the air supply the efficiency will be 76.32 as against 75.62 per cent.

EXAMPLES XVII

1. The diameter of a steam engine cylinder is 40 inches, and of the piston rod 5 inches, and the stroke is 5 feet. The mean effective pressure on the head end of the piston is 40 pounds per square inch, and on the crank end 42 pounds per square inch. If the speed of the engine is 120 revolutions per minute, what is the indicated horsepower?

2. A locomotive has two double-acting cylinders supplied by steam, the admission pressure being 150 lbs. per square inch absolute, and the exhaust pressure 18 lbs. per square inch absolute. The cylinder diameters are 17 inches, stroke 26 inches, and the diameter of the driving wheels 6 feet. Find the tractive effort and the indicated horsepower when running at 40 miles an hour, the cut-off being 0.4. Allow a diagram factor of 0.9 and a mechanical efficiency of 80 per cent.

3. In some trials with a triple expansion engine at constant boiler pressure and number of expansions, it was found that the steam used could be expressed by $W = 678 + 7.16R$, and the mean effective pressure reduced to the L.P. cylinder by $M.P. = 27.4 - 0.042R$, where $W =$ lbs. of steam per hour; $M.P. =$ mean pressure in lbs. per square inch; $R =$ revolutions per minute. Find the speed at which the steam used per hour per I.H.P. is a minimum. State the I.H.P. and the steam used per hour at this speed. Diameter of L.P. cylinder 23 inches, stroke 18 inches. (L. U.)

4. In a trial of a jacketed engine the steam chest pressure was 145 lbs. per square inch absolute, the cylinder feed was 29 lbs. per minute, and the jacket feed was 3.2 lbs. per minute, the feed and jacket steam being 3 per cent. wet. The circulating water was 550 lbs. per minute, inlet temperature $55^{\circ}F.$, outlet temperature $104.3^{\circ}F.$ The feed temperature was $125^{\circ}F.$, and the I.H.P. 110. Draw up a heat balance and find also the thermal efficiency. (L. U.)

5. The following data were obtained from a trial on a steam engine:—

Air pump discharge per hour	6417 lbs.
Weight of steam used in jackets per hour	1079 lbs.
Temperature of jacket drainage	$352^{\circ}F.$
Pressure of steam at boiler side of stop valve (lbs. per sq. in. absolute)	$139^{\circ}0$
Moisture in steam " " " (dry saturated)	nil.
Temperature of exhaust steam	$119^{\circ}F.$
Indicated horse-power	494.3
Circulating water per hour	87,300 lbs.
Inlet temperature of circulating water	$33.2^{\circ}F.$
Outlet " " "	$91.6^{\circ}F.$

Draw up a heat account for this engine and in addition calculate—

- Steam consumption per I.H.P. hour.
- Thermal efficiency of the engine.
- Heat theoretically required per minute per I.H.P. by an engine working on the Rankine cycle between the above temperatures.
- Efficiency ratio or coefficient of performance.

6. The flue gases from a boiler pass around the tubes of an economiser. The temperature of the gases entering the economiser is $315^{\circ}C.$, and on leaving it $149^{\circ}C.$ The amount of feed water passing through the tubes is 90 pounds per minute; the temperature of the water entering the economiser is $38^{\circ}C.$, and on leaving $115^{\circ}C.$

If the boiler evaporates 10 pounds of water per pound of coal, find approximately the weight of air supplied per pound of coal burned. Assume that the specific heat of the gases is 0.25.

7. In a boiler trial 3600 pounds of coal were consumed in 24 hours. The weight of water evaporated was 28,800 pounds, mean steam pressure by gauge 95 pounds. The coal contained 3 per cent. of moisture and 3.9 per cent. of ash by analysis. Determine the efficiency of the boiler and the equivalent evaporation from and at $212^{\circ}F.$ (1) per pound of dry coal, (2) per pound of combustible. Feed temperature $95^{\circ}F.$, total heat of 1 pound of steam at 110 lbs. per square inch absolute, 1184 B.Th.U., calorific value of one pound of the dry coal 13,000 B.Th.U.

8. The following data were obtained during a boiler trial:—

Feed water per hour	10,115 pounds
Temperature of feed to boiler	$174^{\circ}F.$
Steam pressure (lbs. per square inch absolute)	170
Moisture in 1 pound of steam	0.019 pound
Coal fired per hour	1074 pounds
Dry coal " "	1054 " "
Calorific value of dried coal	14,000 B.Th.U. per pound
Analysis of dried coal	C 88 %, H ₂ 3.6 %, ash 3.6 %, other matters 4.8 %
Calorific value of ashes	900 B.Th.U. per pound
Weight of ashes per hour	38 pounds
Analysis of flue gases by volume	CO ₂ 10.9 %, CO 1.0 %, O ₂ 7.1 %, N ₂ 81.0 %
Temperature of flue gases leaving boiler	$600^{\circ}F.$
Temperature of air in boiler house	$60^{\circ}F.$

Draw up a heat account for this boiler.

CHAPTER XVIII

VALVE DIAGRAMS AND VALVE GEARS

215. Slide Valves.—The functions of a slide valve are to admit steam to the engine cylinder; to cut off the steam; to release the steam from the cylinder by placing it in direct communication with the exhaust pipe and to close the exhaust passage before the end of the exhaust stroke in order that the steam left in the cylinder may be compressed, and in the act of so doing “cushion” the reciprocating masses.

The valve is shown diagrammatically in Fig. 161, which represents a longitudinal section through the steam-chest of an engine cylinder. The valve *V* is given a reciprocating motion by means of the eccentric rod *R*,

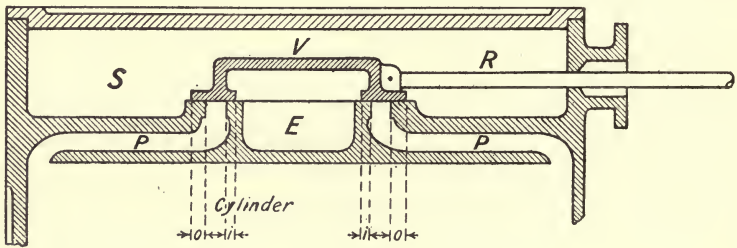

FIG. 161.

which is driven by an eccentric keyed on the crank-shaft of the engine. Steam is continuously supplied into the steam-chest *S* and admitted to the cylinder, when the valve uncovers the steam ports *P* from the outside of the valve. The inside of the valve is coupled up to the exhaust pipe *E*, and when the inside of the valve opens the ports *P* the cylinder is put into communication with the exhaust.

Outside and Inside Laps.—When the valve is placed in the middle of its stroke, the distance *o* by which the outside or admission edge of the valve overlaps the edge of the steam port is called the “*outside*” or “*steam lap*”, and the distance *i*, by which the inside edge of the valve overlaps the inside edge of the steam port, is called the “*inside*” or “*exhaust lap*”. The outside lap regulates the admission of steam and the cut-off, whilst the inside lap looks after the points of release and compression. If the engine is to work non-expansively (*i.e.* if steam is admitted for the full stroke of the piston), with no compression, both the outside and inside laps must be equal to zero and the eccentric centre must be placed

90° *in advance* of the crank, the width of the valve face being equal to the width of the steam port.

In some cases the valve may not close the ports when in its mid position ; in such cases there will be a small width of port standing open either on the exhaust or on the steam side, and the port opening on the outside of the valve is called the *negative outside lap*, the port opening on the inside of the valve being called the *negative inside lap*. Negative outside, or steam, lap is rarely used, but a negative inside lap is more common.

Lead and Angle of Advance.—The actual opening of the valve to steam when the crank is on the dead centre, *i.e.* when the piston is at the beginning of its working stroke, is called the *lead* of the valve.

The *angle of advance* (θ) is the angle in excess of 90° by which the eccentric centre is in advance of the crank. The angular advance is the angle by which the eccentric leads the crank, *i.e.* $90 + \theta$.

Consider the motion of the valve from its mid position to the end of its stroke. Before the valve can open to steam it must travel a distance equal to the outside lap ; the remainder of its stroke will give the maximum opening of the valve to steam, provided that the width of the steam port is not less than this distance. Let r denote the “throw” of the eccentric or *half* the stroke of the valve, and s the maximum opening of the valve to steam, then

$$\begin{aligned} \text{half travel} &= \text{outside lap} + \text{maximum opening to steam} \\ r &= o + s \end{aligned} \quad \dots \dots \dots (1)$$

Similarly for the inside of the valve—

$$\begin{aligned} \text{half travel} &= \text{inside lap} + \text{maximum opening to exhaust} \\ r &= i + e \end{aligned} \quad \dots \dots \dots (2)$$

where e denotes the maximum opening to exhaust.

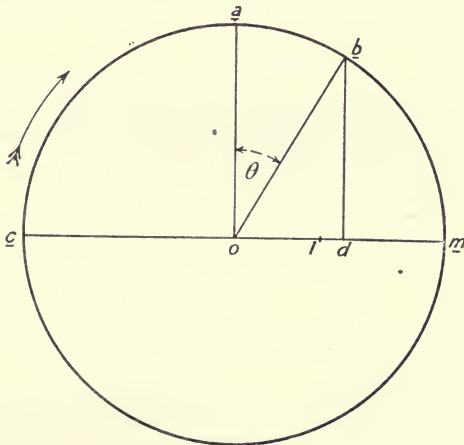

FIG. 162.

Since the valve cannot open a greater distance than the full width of the port, it is evident that the distances $r - o$ and $r - i$ will give the

maximum openings to steam and exhaust respectively only when they do not exceed the width of the port.

The angle of advance may be obtained by the following simple construction :—

Draw a circle of radius r , the diameter therefore being equal to the stroke of the valve. On a horizontal diameter set of ol (Fig. 162) equal to the outside lap o , and ld equal to the lead of the valve. Erect perpendiculars at o and d and join ob . Then the angle adb will be the angle of advance (θ) required, and the eccentric centre will lead the crank by the angle $cod = 90^\circ + \theta$.

Since Fig. 162 is drawn to represent the path of the eccentric centre, and further, since in almost every case in practice the length of the eccentric rod driving the valve is great compared with the throw of the eccentric, the valve will describe a simple harmonic motion along cm of amplitude r , and for any position of the eccentric, such as b , the displacement of the valve from midstroke, when the crank is on the dead centre, will be given by od , or

$$od = r \sin \theta (3)$$

If the crank has turned through an angle α from its dead centre, the general expression for the displacement of the valve will be (Fig. 163)—

$$x = r \sin (\alpha + \theta) (4)$$

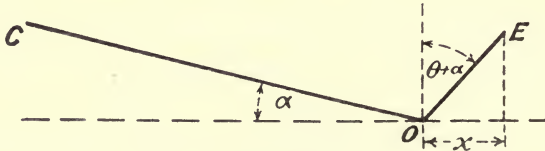

FIG. 163.

In the particular position shown in Fig. 162

$$x = od = \text{outside lap} + \text{lead} = r \sin \theta,$$

or
$$o + l = r \sin \theta (5)$$

where l denotes the *lead* of the valve

216. Piston Displacement Curve.—The piston will not execute a simple harmonic motion, because the connecting rod is not infinitely long. Draw AO (Fig. 164) to represent the line of stroke, and with centre O draw in the crank-pin circle, the diameter of which will represent the stroke of the engine to any convenient scale. Draw on the centre lines of the crank and connecting rod for any crank angle. With centre A and radius AC (the length of the connecting rod) draw the arc CP to cut the line of stroke in point P , then when the crank is at C the piston is evidently OP from the middle of its stroke. If this construction be repeated for a number of different positions of the crank, the piston displacement may be found for any crank angle.

A more convenient construction is obtained by drawing in the arc DOE of radius equal to the length of the connecting rod AC , and whose centre lies at a point in the line of stroke OA . If now a line CC' be drawn

parallel to OA, CC', which is equal to OP, will represent the displacement of the piston from midstroke. Proceeding in this way and taking crank-

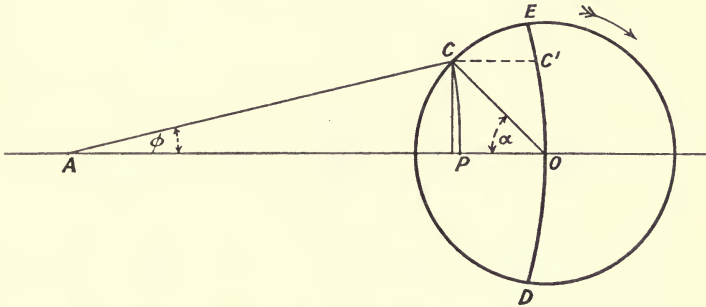

FIG. 164.

angles, say, every 30°, the piston displacement curve may be drawn as shown in Fig. 165.

An algebraic expression for the piston displacement may readily be found as follows:—

Let l = length of connecting rod.

r = length of crank.

n = ratio of length of connecting rod to length of crank = $\frac{l}{r}$.

α = crank angle measured from the inner dead centre.

ϕ = inclination of connecting rod to line of stroke.

Then referring to Fig. 164

$$\begin{aligned} OP = x &= r \cos \alpha - (l - l \cos \phi) \\ &= r \cos \alpha - l(1 - \cos \phi) \end{aligned} \quad \dots \dots (1)$$

But $r \sin \alpha = l \sin \phi$

$$\therefore \sin \phi = \frac{r}{l} \sin \alpha = \frac{1}{n} \sin \alpha$$

and

$$\begin{aligned} \cos \phi &= \sqrt{1 - \sin^2 \phi} \\ &= \sqrt{1 - \frac{\sin^2 \alpha}{n^2}} \\ &= \frac{1}{n} \sqrt{n^2 - \sin^2 \alpha} \end{aligned} \quad \dots \dots (2)$$

(2) in (1) gives

$$\begin{aligned} x &= r \cos \alpha - l \left(1 - \frac{1}{n} \sqrt{n^2 - \sin^2 \alpha} \right) \\ &= r \cos \alpha - l + r \sqrt{n^2 - \sin^2 \alpha} \end{aligned} \quad \dots \dots (3)$$

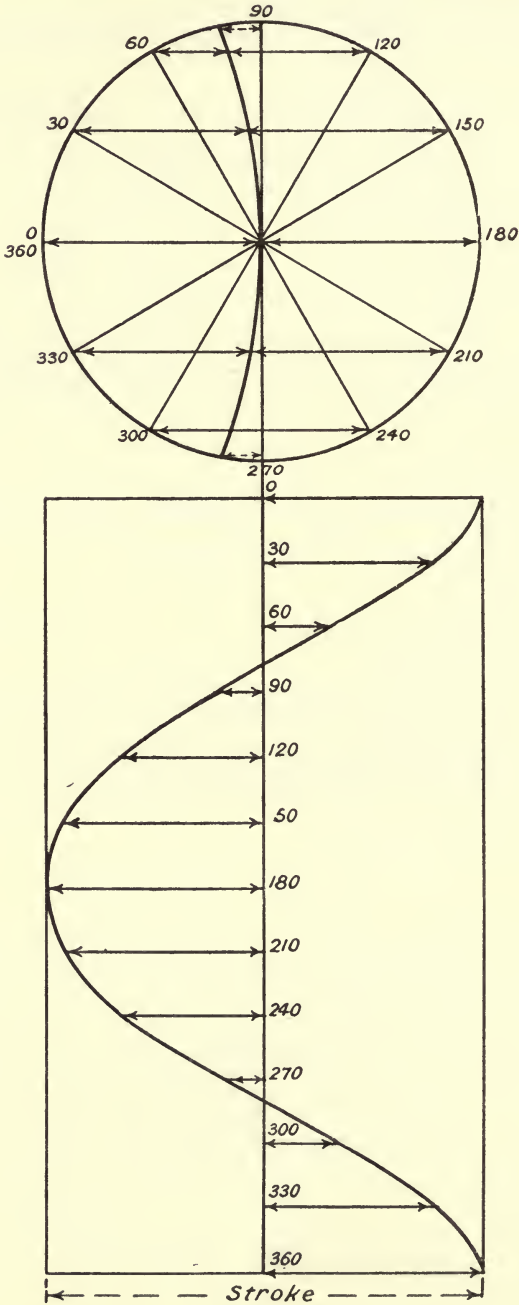

FIG. 165.

Expanding $\sqrt{n^2 - \sin^2 \alpha}$ and using the first two terms only we have an approximate expression for x , namely

$$\begin{aligned}
 x &= r \cos \alpha - l + r\left(n - \frac{1}{2n} \sin^2 \alpha + \dots\right) \\
 &= r \cos \alpha - l + rn - \frac{r}{2n} \sin^2 \alpha \\
 &= r \cos \alpha - \frac{r}{2n} \sin^2 \alpha \dots \dots \dots (4)
 \end{aligned}$$

and since $\sin^2 \alpha = \frac{1}{2}(1 - \cos 2\alpha)$ this becomes

$$\begin{aligned}
 x &= r \cos \alpha - \frac{r}{2n} \cdot \frac{1}{2}(1 - \cos 2\alpha) \\
 &= r \cos \alpha - \frac{r^2}{4l}(1 - \cos 2\alpha) \dots \dots \dots (5)
 \end{aligned}$$

If the obliquity of the eccentric rod be not neglected (4) will give the displacement of the *valve* from midstroke instead of (4), Art. 215, in which case r will be the throw of the eccentric and l the length of the eccentric rod.

217. Rectangular Valve Diagram.—For a given ratio of length of connecting rod to length of crank the piston displacement curve is first drawn either by the graphical method described in Art. 216, or plotted on, say, squared paper from equations (3) or (4), Art. 216. On the same diagram the valve displacement curve is plotted at the proper phase angle, as shown in Fig. 166. Since the eccentric leads the crank by an angle $90^\circ + \theta$, it is evident that the valve reaches its maximum displacement at a point $90^\circ + \theta$ before the piston reaches its maximum displacement. Consider now the *instroke*, i.e. the stroke *towards* the crank shaft, the steam acting on the *head* end of the piston. Draw a line SS to the left of and parallel to AA, and distant from it the outside lap o , to the same scale as the valve displacement curve. At point C, where SS cuts the valve displacement curve, the valve is closed and cut-off occurs. From C project horizontally to cut the piston displacement curve, and the fraction of the piston's stroke at which cut-off occurs can be read off directly. At the point B, where SS again cuts the valve displacement curve, admission occurs. The horizontal distances between SS and the valve displacement curve up to cut-off give the opening of the valve to steam, the distance when the crank angle is zero being the *lead*.

For the exhaust side of the valve draw EE parallel to AA and distant from it the inside lap i . At point R, where this line cuts the valve displacement curve, the valve is just on the point of opening to exhaust and release occurs. From R project horizontally to cut the piston displacement curve, and the fraction of the stroke at which release occurs can be read off directly. At point M, where EE again cuts the valve displacement curve, compression commences. The horizontal distances between EE and the piston displacement curve between R and M give the opening of the valve to exhaust.

2 inches and $90^\circ + 30 = 120^\circ$ from the piston displacement curve as shown. Then draw the two lap lines.

On the Instroke (on the head end of the piston).—Admission takes place at point B near the end of the compression stroke at 0.995 of the stroke, the lead scaling 0.2 inch. Cut-off takes place at point C at 0.83 of the

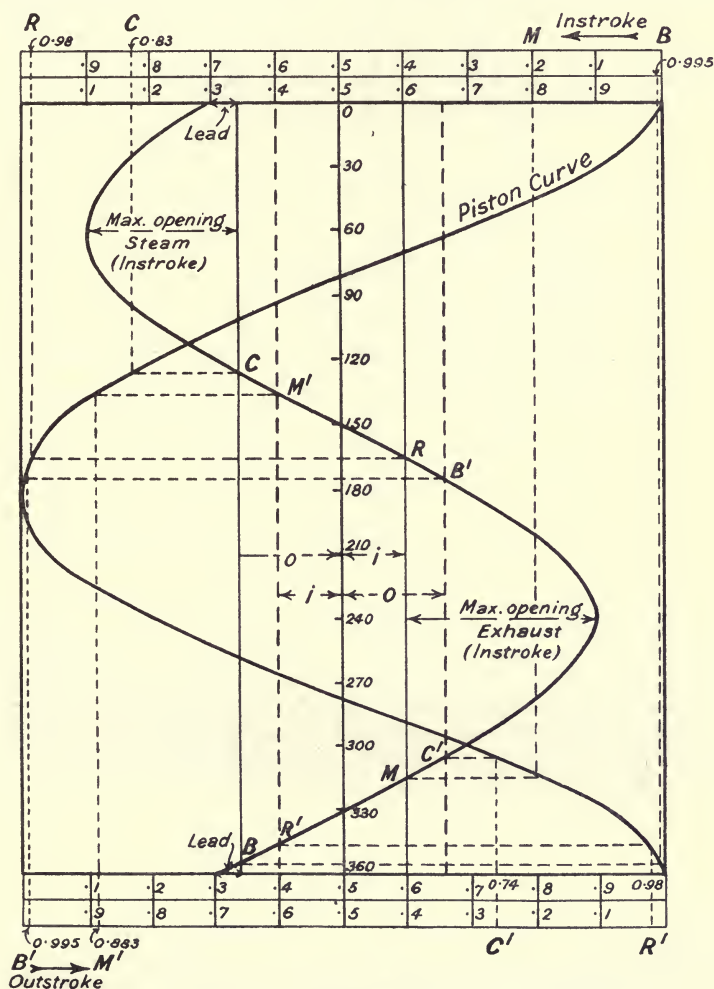

FIG. 167.

stroke. Release takes place at R at 0.98 of the instroke, and compression commences at M at 0.8 of the exhaust stroke.

On the Outstroke (steam on the crank end of the piston).—Draw the two lap lines shown dotted. Admission occurs at B' at 0.995 of the return stroke, the lead being 0.2 inch. Cut-off occurs at C' at 0.74 of the stroke.

Release occurs at R' at 0.98 of the stroke, and compression commences at M' at 0.883 of the stroke.

218. Reuleaux Valve Diagram.—To set out this diagram draw a circle whose diameter is equal to the travel of the valve. The diameter AB (Fig. 168) represents to scale the stroke of the engine, and the circle represents to scale the crank-pin circle, A and B being the inner and outer

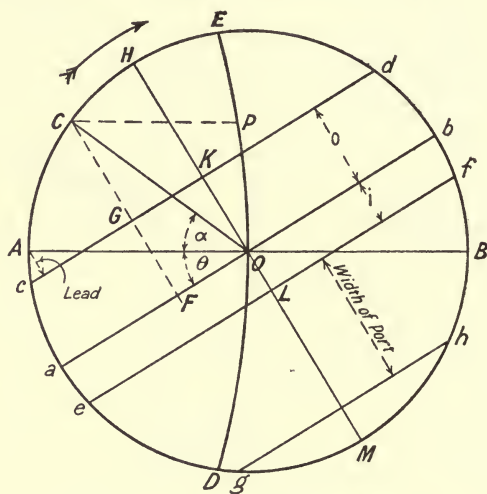

FIG. 168.

dead centres respectively. Draw another diameter ab inclined θ to AB , where θ is the angle of advance of the eccentric. On AB (produced towards the left) as centre, and with a radius equal to the length of the connecting rod to the same scale that AB represents the stroke, draw the arc ED passing through the centre of the valve circle. The line ab is called the valve displacement line, and for any position of the crank, such as C at α° from the inner dead centre, the perpendicular CF drawn on to ab gives the displacement of the valve from the middle of its stroke. This is at once evident from the fact that

$$\begin{aligned} CF &= OC \sin \angle aOC \\ &= r \sin (\alpha + \theta), \end{aligned}$$

which by (4), Art. 215, is equal to the displacement of the valve from midstroke.

A horizontal line CP parallel to AB gives to scale the displacement of the piston from midstroke, as explained in Art. 216.

Now draw a line cd parallel to ab and distant o , the outside lap from it, and a line ef parallel to ab and distant i , the inside lap from it; cd is called the steam line, and ef the exhaust line. A perpendicular, such as CG , from any crank position C on to cd gives the opening of the valve to steam. The maximum opening to steam will evidently be HK . Similarly, perpendiculars from various crank positions between f and e , and below fe ,

will give the opening to exhaust. In case the maximum opening LM should be greater than the full width of the port, draw a line gh parallel to ef and distant from it the width of the port. Then, whilst the crank travels round from h to g , the valve is fully open to exhaust, a distance equal to the width of the port. Fig. 168 shows the Reuleaux diagram for the head end of the piston, *i.e.* the instroke; c is the point of admission, the perpendicular from A on to cd is the lead, d is the point of cut-off, f the point of release, and e the point when compression begins.

The complete Reuleaux diagram for both strokes is obtained by adding lines $c'd'$ and $e'f'$ parallel to ab , and distant from it the outside and inside laps respectively, as shown in Fig. 169, which is drawn for equal inside

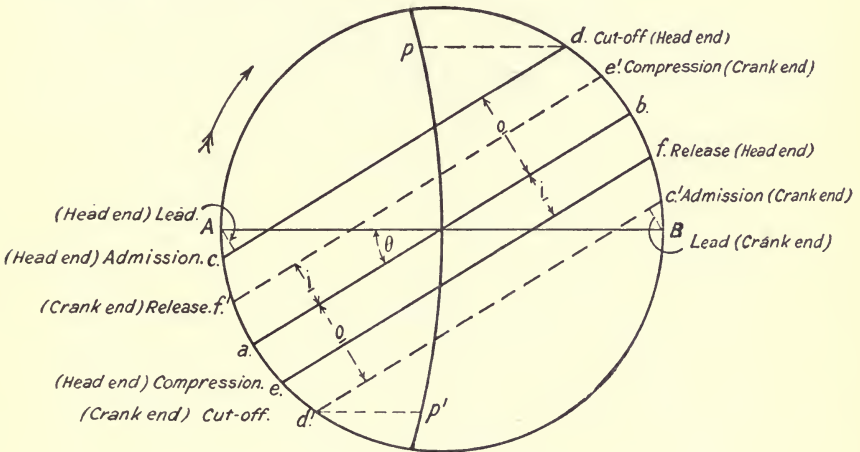

FIG. 169.

and outside laps. By inspection of Fig. 169 it will be evident that with equal laps cut-off takes place earlier on the crank end than on the head end of the piston, $d'p'$ being less than dp ; but the leads are equal. In order to equalise the cut-offs the outside lap on the crank end may be made less than on the head end of the piston, but if this be done the leads will be unequal.

219. Zeuner Valve Diagram.—This construction gives a polar diagram for the valve displacement, and may be explained as follows: Draw a circle whose diameter AB (which represents to scale the stroke of the piston) is equal to the travel of the valve, and draw another diameter DE (Fig. 170), inclined θ to the normal to AB. On DE draw a pair of circles, whose diameters are both equal to half the travel of the valve. Then for any position of the crank, such as C, the length PO gives the displacement of the valve from midstroke.

Proof. From C drop a perpendicular on to DE, and join EP. Since EP is perpendicular to OC the two triangles PEO and CQO are similar, and since $OC = OE$ it is evident that $PO = OQ$. Now, OQ is equal to the displacement of the valve from its mid-position when the crank is at C, hence the displacement of the valve is also given by PO.

To complete the diagram for the head end of the piston, with centre O and radius equal to the outside lap, draw the circle RS , and with the same

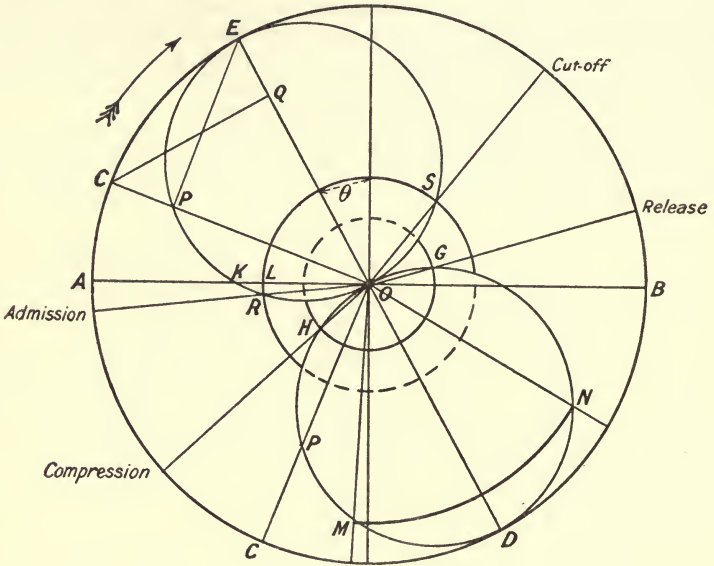

FIG. 170.

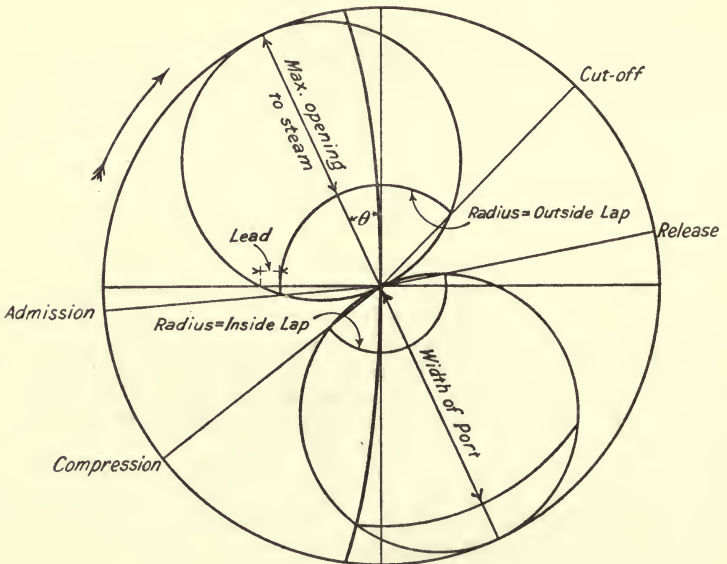

FIG. 171.

centre, and with radius equal to the inside lap, draw the circle GH. When the crank has the direction OR admission occurs; OS is the position of the crank at cut-off, OG at release, and OH when compression begins. The length KL is the opening to steam when on the dead centre, *i.e.* the *lead* of the valve. The diagram is completed by drawing, with centre O and radius equal to the width of port, the arc MN; the valve is then fully open to exhaust while the crank turns from the position ON to the position OM.

The position of the piston for any crank position may be most conveniently found by the construction already given in Art. 216 for the Reuleaux diagram. For the sake of clearness the complete Zeuner diagram for the head end of the piston is reproduced in Fig. 171.

220. The Oval Valve Diagram.—This diagram is commonly used by locomotive engineers *after* the valve has been designed, and shows directly the position of the piston for any position of the valve. On a base AB (Fig. 172), which represents the stroke of the piston, a curve is plotted,

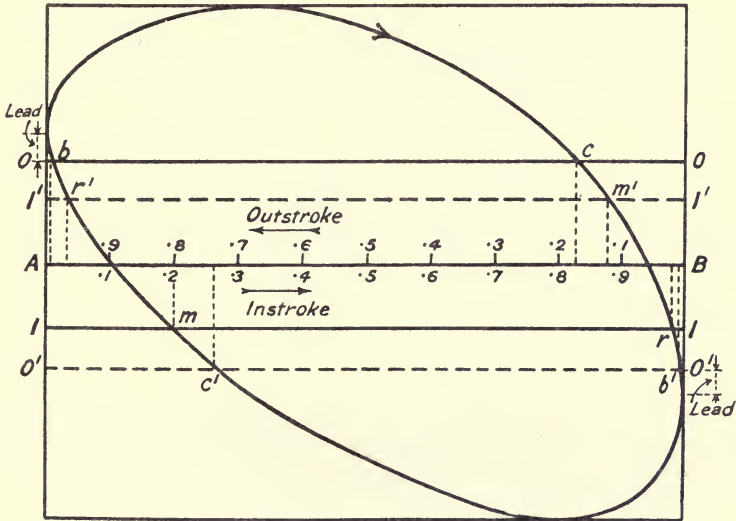

FIG. 172.

having for ordinates the displacement of the valve. For any piston position the valve displacement may be found by any of the methods described above, and the ordinate suitably increased, if necessary, to prevent the curve being too flat. Fig. 172 is drawn from the same data as the rectangular valve diagram shown in Fig. 167, namely, $n = 4$, $r = 2$ inches, $\theta = 30^\circ$, outside lap (both ends), 0.8 inch, inside lap (both ends), 0.5 inch.

Next draw OO and II above and below AB, and parallel to it at distances equal to the outside and inside laps respectively. For the *instroke* b is the point of admission at 0.995 of the compression stroke, c the point of cut-off at 0.83 of the stroke, r the point of release at 0.98 of the stroke, and m the point where compression begins at 0.8 of the stroke.

222. Choice of a Valve Diagram.—For most purposes (particularly when under examination) the Reuleaux diagram offers the most convenient method of solving problems connected with a simple eccentric valve gear, although either the Zeuner, Rectangular, or Bilgram diagram might be used. If the travel of the valve is not given, then the Bilgram diagram must be used. All problems of this type that can be solved by the Zeuner diagram can be solved by the Reuleaux diagram, in some cases with greater convenience. The following are a few typical examples, together with the method of solution:—

Problem 1. Given, travel, angle of advance, and outside lap.

Required, admission, lead and point of cut-off.

The solution using the Reuleaux diagram is shown in Fig. 174, and

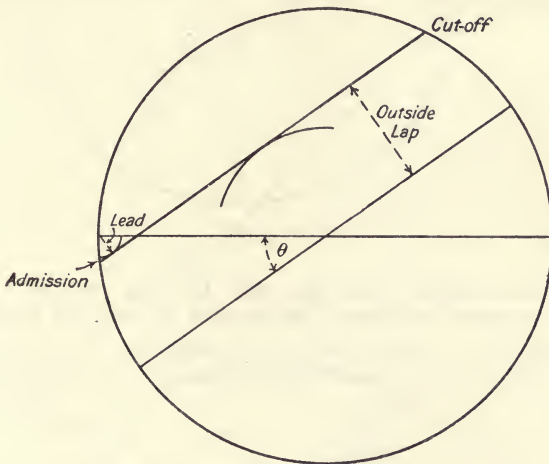

FIG. 174.

requires no further explanation. Fig. 174A shows the Zeuner diagram. The corresponding positions of the piston may be easily found. There is little to choose between either of these diagrams in this particular case.

Problem 2. Given, travel, lead, outside lap, and point of release.

Required, cut-off, angle of advance, inside lap, compression, and maximum opening to steam.

The Reuleaux diagram is the most convenient for the rapid solution of this problem. Draw the valve circle with centre O (Fig. 175), and radius equal to the half-travel. With centre A and radius equal to the lead describe a circle, and with centre O and radius = outside lap describe another circle. Next draw an internal tangent to the lap and lead circles, and through O draw the displacement line parallel to it. These give admission, cut-off, and angle of advance θ . Through O draw a line perpendicular to the displacement line, and scale off the maximum opening to steam.

Next, mark on the given position of the crank at release, and through this point draw parallel to the displacement line and scale off the inside lap and the point where compression begins.

*Problem 3. Given, cut-off, lead, and maximum opening to steam.
 Required, outside lap, angle of advance, and travel of the valve.*

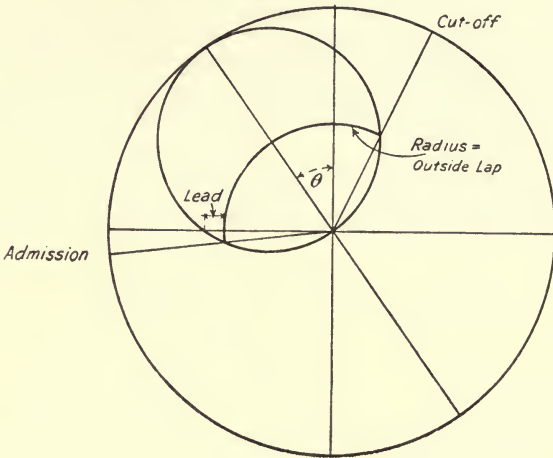

FIG. 174A.

The Bilgram diagram must be used for this purpose. Draw AO (Fig. 176) to represent the line of stroke, and CC parallel to and distant

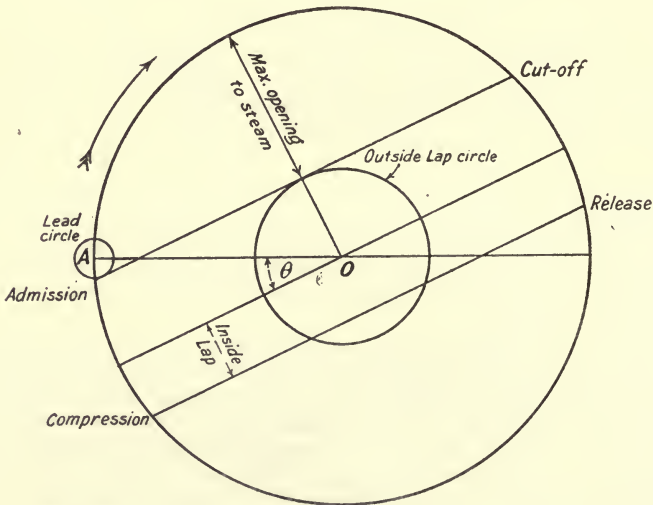

FIG. 175.

the lead from it. Draw a line to show the given direction of the crank at cut-off, and bisect the angle CMN by the line MP. With centre O and

radius equal to the maximum opening to steam, draw the arc L. The outside lap circle must just touch the arc L and the lines CC and MN. Draw

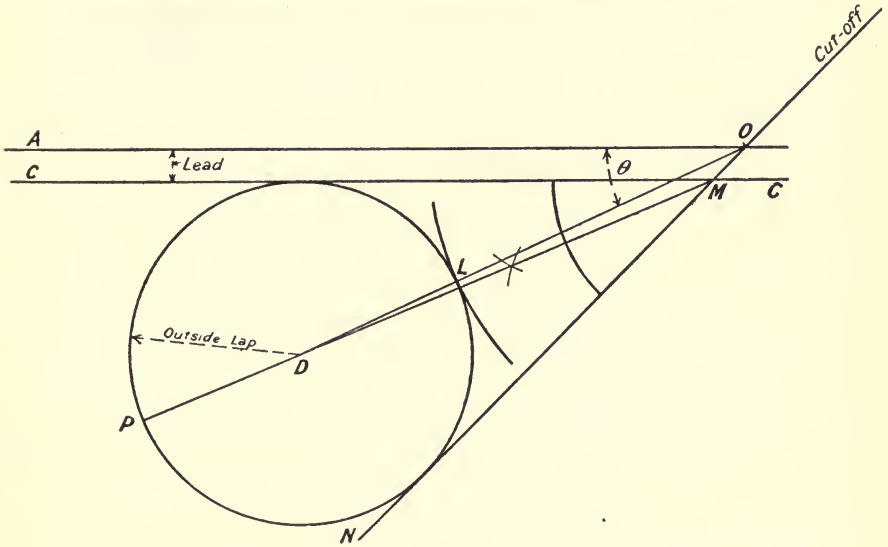

FIG. 176.

this circle in by trial ; its radius will be the outside lap required ; join OD. Then OD will be half the travel of the valve and the angle AOD, the angle of advance.

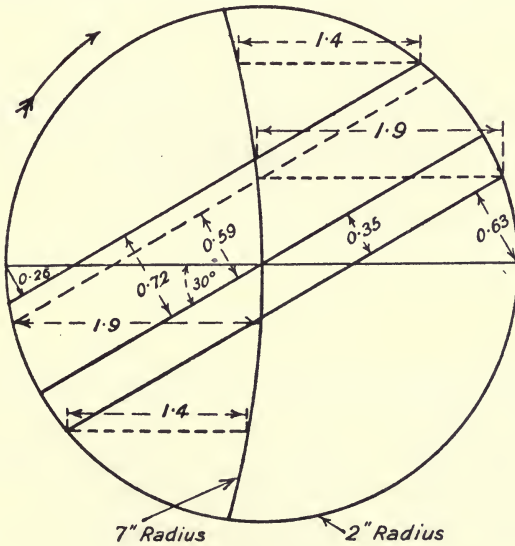

FIG. 177.

Problem 4. Given, connecting rod, $3\frac{1}{2}$ cranks long; travel of valve, 4 inches; angle of advance, 30° ; cut-off, 0.7 stroke at both ends; release, 0.95 of stroke at both ends.

Required, outside and inside laps and the lead for each end of the valve.

The Reuleaux diagram is shown in Fig. 177, and requires no further explanation. In this particular case, the inside lap on the head end and the outside lap on crank end must both be equal to 0.35 inch. The other particulars required are:—

	Outside lap.	Inside lap.	Lead.
Head end	0.72"	0.35"	0.26"
Crank end	0.35	0.59	0.63

223. Analytical Solution.—This method of solution will be best illustrated by means of an example. Let the travel of the valve be 4 inches, angle of advance 30° , outside lap for both ends 0.75 inch, inside lap for both ends 0.4 inch, and length of connecting rod = 4 cranks.

The equation to the valve displacement curve is

$$x = r \sin(\alpha + \theta) \quad ((4), \text{ Art. 215})$$

$$= 2 \sin(\alpha + 30)$$

which may also be written

$$x = 2 \cos(\alpha + 120)$$

Let displacements to the *left* of mid position, *i.e.* when the crank is between the inner dead centre and the position for which the valve is at midstroke, be called *negative*, and displacements to the *right* be called positive. Then at the inner dead centre $\alpha = 0$, and for the head end of the piston, *i.e.* the instroke

$$x = 2 \cos 120^\circ = -1$$

The valve is therefore 1 inch from midstroke, and the lead is obviously

$$1 - \text{outside lap}$$

$$= 1 - 0.75 = 0.25 \text{ inch}$$

For the outstroke the lead will also be 0.25 inch.

To find the points of cut-off and admission.—At both of these points the displacement of the valve will be = 0.75 inch from midstroke.

$$\therefore -0.75 = 2 \cos(\alpha + 120)$$

$$\therefore \cos(\alpha + 120) = -0.375$$

From tables we find that 0.375 is the value of $\cos 68^\circ$ nearly, but since the sign is negative, the two angles having this value (-0.375) for their cosine are

$$180 - 68 = 112^\circ \quad \therefore \alpha + 120 = 112 \quad \text{or } \alpha = -8^\circ \text{ or } 352^\circ$$

$$\text{and } 180 + 68 = 248^\circ \quad \therefore \alpha + 120 = 248 \quad \text{or } \alpha = 128^\circ$$

$$\therefore \text{crank angle from inner dead centre at admission} = -8^\circ \text{ or } 352^\circ$$

$$\text{and " " " " " cut-off} = 128^\circ$$

224. Earliest Cut-off possible with a Simple Eccentric Valve Gear.—Two considerations limit the earliness of cut-off in practice. With a given travel and lead, cut-off may be made earlier by increasing the outside lap, but a limit is soon reached because the act of increasing the lap will decrease the maximum opening to steam with the result that the steam will be badly throttled, and the loss due to wiredrawing (p. 105) excessive. This is clearly shown in Fig. 178, which shows the steam lines

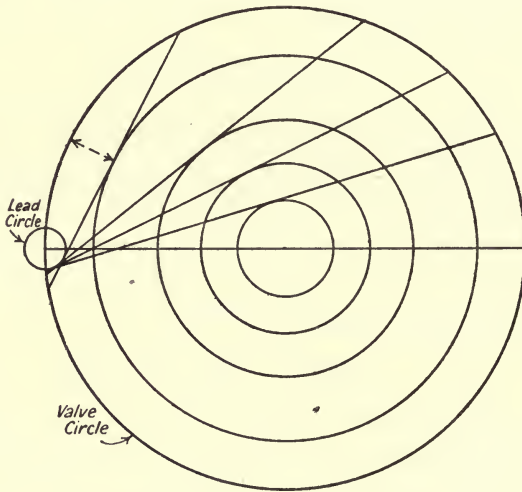

FIG. 178.

for increasing outside laps. In addition to the greatly reduced opening to steam the angle of advance is also increased, which of course will result in earlier compression. To avoid, therefore, a too small opening to steam and too early compression with a simple eccentric gear, the cut-off is not usually made earlier than half-stroke.

225. The Meyer Expansion Valve Gear.—In order to obtain an early and a variable cut-off without the disadvantages mentioned in the previous Art., the Meyer gear is commonly used. It consists of (1) a main slide valve M (Fig. 179) driven by one eccentric, and which is designed to cut-off steam at the latest point ever required and which always admits, releases, and compresses the steam; and (2) a separate expansion valve or pair of plates, EE, which slide over the back of the main valve, and which are driven by another eccentric and arranged in such a manner that the distance apart of the plates, and therefore the lap "a," can be varied in order to vary the point of cut-off in the engine cylinder.

Virtual, or Equivalent Eccentric.—For any position of the gear let E_m (Fig. 180) be the position of the main eccentric, and E_e the position of the expansion eccentric. Draw OE_v parallel to E_mE_e , and E_eE_v parallel to OE_m , and E_eN , E_mM , and E_vP perpendicular to OM .

when the engine is intended to reverse, because, in reversing, the main valve alone is altered, and it is obvious that to secure equal grades of expansion for either direction of running, the expansion eccentric must be placed in the symmetrical position diametrically opposite to the crank.

To find the events of the cycle we can treat E_v just as an ordinary eccentric if we know its angle of advance λ . The angle of advance (λ) of the virtual eccentric may be found as follows:—Let C be the position (Fig. 181) of the crank when on the inner dead centre. Let off OE_m to represent the throw of the main eccentric, the angle $\hat{B}OE_m$ being its angle of advance; set off OE_e diametrically opposite to OC to represent the expansion eccentric. Join E_mE_e and draw OE_v parallel to and equal to E_mE_e . Then OE_v is the throw of the virtual eccentric, and angle $\hat{B}OE_v$ its angle of advance λ .

Either the Reuleaux or the Zeuner valve diagrams may now be used to find the point of cut-off, etc.

Using the Reuleaux diagram, draw a circle of radius equal to the throw of the virtual eccentric, and set out the displacement line bd (Fig. 182) at an angle λ to AB . Draw the line cf parallel to db and

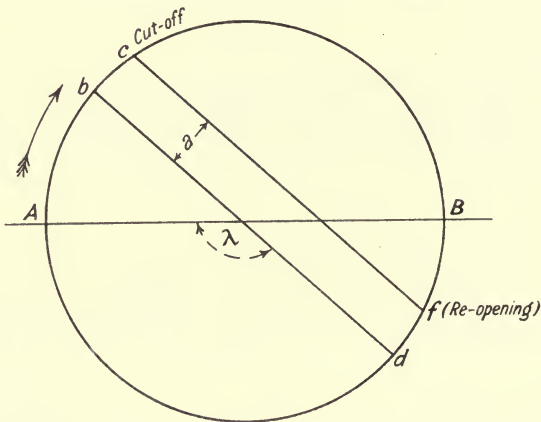

FIG. 182.

distant “ a ” from it, then c will be the position of the crank at cut-off, and when the relative displacement is again reduced to an amount “ a ” the expansion valve will reopen; the main valve must have sufficient outside lap to ensure its being closed by this time or readmission to the engine cylinder will occur.

The expansion valve is usually provided with a means (such as a right- and left-handed screw, Fig. 179) of altering the distance “ a ” and so making the cut-off early or late. The limit of earliness is imposed by the condition that the distance “ a ” must not be reduced below the amount necessary to give a fair steam opening, and the limit of lateness being imposed by the consideration that the main valve itself becomes closed at a position determined by its own outside lap.

EXAMPLE I. Given the earliest and the latest cut-off ever required to find the values of “ a ” to be provided.

This problem may be conveniently solved as follows:—

Draw the main valve circle (Fig. 183) of diameter equal to the travel

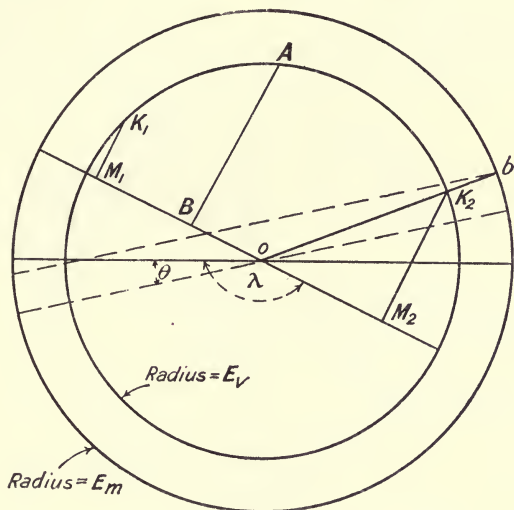

FIG. 183.

of the main valve. Find the position of the crank at the latest cut-off required and design the main valve to give the latest cut-off at b and suitable points of release, compression and admission.

Next find the virtual eccentric and put in the circle with E_v as radius. Join ob , cutting the circle E_v in K_2 and draw the perpendicular K_2M_2 on to the displacement line. The length of K_2M_2 gives the value of " a " to be provided.

Next find the position of the crank for the earliest cut-off. Suppose this is at K_1 , then the perpendicular K_1M_1 gives the value of " a " to be provided.

If now the value of " a " be required for any other cut-off, all that is required is to find the crank position at cut-off (say A), and the length of the perpendicular AB gives the value of " a " required.

EXAMPLE 2.—In a Meyer valve gear the travel of the main valve is 4 inches, angle of advance $22\frac{1}{2}^\circ$, lead $\frac{1}{4}$ inch, and inside lap $\frac{3}{8}$ inch. Find and state the piston positions at (a) main valve cut-off; (b) at release; (c) at compression; (d) steam port opening at 0.1 of stroke; (e) port opening to exhaust at end of working stroke; (f) outside lap of main valve.

If the travel of the expansion valve is 4 inches, its angle of advance 90° , and the width of the port through the main valve is $1\frac{1}{2}$ inches. Find the distance from the edge of the expansion valve to the outer edge of the port through the main valve to cut-off at 0.2 and at 0.5 stroke. In the former case find the width of the narrowest expansion plate that may be used. Connecting rod 3.5 cranks long.

We will solve this problem by using the Reuleaux diagram and also by the rectangular diagram.

Main Valve.—The Reuleaux diagram is shown in Fig. 184 for the head end of the piston only, the results being:—

- (a) Cut-off at 0.92 of the stroke.
- (b) Release at 0.99 " " "
- (c) Compression at 0.89 of the stroke.

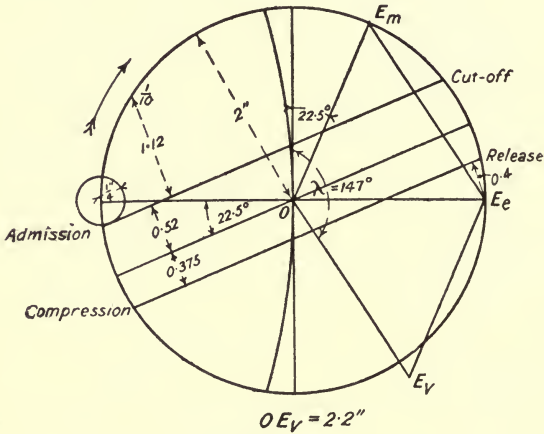

FIG. 184.

- (d) Opening to steam at 0.1 of stroke = 1.12 inch.
- (e) Exhaust lead 0.4 inch.
- (f) Outside lap 0.52 inch.

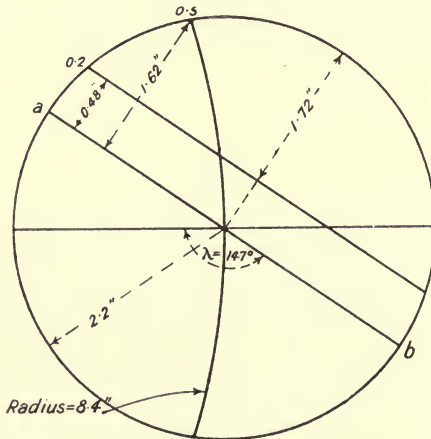

FIG. 185.

Expansion Valve.—First find the virtual eccentric. This is shown in Fig. 184, $OE_v = 2.2$ inches and $\lambda = 147^\circ$. Then find the positions of the crank at 0.2, and at 0.5 of the stroke (see Fig. 185) and scale off the

perpendicular distances from these points to the displacement line; it will be found that they are 0.48 inch and 1.62 inch respectively. From Fig. 185 the maximum opening to steam, or rather the throw of the equivalent eccentric *minus* 0.48 is $2.2 - 0.48 = 1.72$ inch. Now during the time that the relative movement of the expansion plate over the main valve is 1.72 inches the port through the main valve is open, hence the width of the narrowest plate must be this distance *plus* the width of the port:—

$$\text{i.e. } 1.72 + 1.5 = 3.22 \text{ inches.}$$

Rectangular Diagram.—The piston and main valve curves are drawn in the usual way as explained in Art. 216. The expansion valve curve is

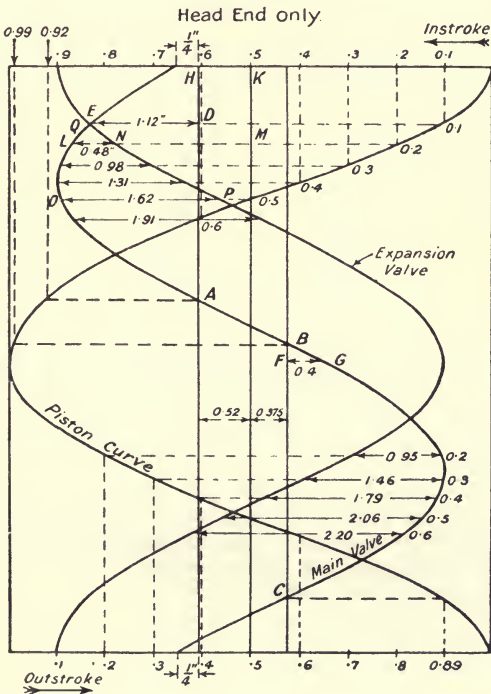

FIG. 186.

then added as shown in Fig. 186. The results are the same as before, namely:—

Main Valve.

- (a) Cut-off at 0.92 of the stroke at A.
- (b) Release at 0.99 " " B.
- (c) Compression at 0.89 of the stroke at C.
- (d) Opening to steam at 0.1 of stroke = DE = 1.12 inch.
- (e) Exhaust lead = FG = 0.4 inch.
- (f) Outside lap = HK = 0.52 inch.

Expansion Valve.—When the piston is at 0·2 of its instroke the main valve is the distance LM from its mid-position, and the expansion valve the distance NM from its mid-position. The distance of the centre of the expansion valve from the centre of the main valve, *i.e.* the lap “*a*,” is therefore—

$$LM - NM = LN = 0\cdot48 \text{ inch (as before).}$$

Similarly when the piston is at 0·5 of its stroke the distance of the centre of the expansion valve from the centre of the main valve is—

$$OP = 1\cdot62 \text{ inch (as before)}$$

It should be noted that when $a = 0$, *i.e.* at the point *a* in Fig. 185, and at Q in Fig. 186, cut-off occurs at 0·11 of the stroke. If the lap “*a*” be made positive, then cut-off could be obtained earlier than 0·11 of the instroke.

The various laps required for different cut-offs on the head and crank end of the piston are further shown in Fig. 186 and also tabulated below :—

Cut-off.	Head end.	Crank end.	Difference.
0·2	0·48	0·95	0·47
0·3	0·98	1·46	0·48
0·4	1·31	1·79	0·48
0·5	1·62	2·06	0·44
0·6	1·91	2·20	0·29

The right-hand column gives the differences between the laps required to give equal cut-offs at the stated fractions of the stroke. If the expansion plates be adjusted so that the laps are 0·98, and 1·46 for the head and crank end respectively, the cut-offs will be equal at 0·3 and 0·4 of the stroke, and nearly equal at 0·2 and 0·5 of the stroke.

226. Analytical Solution of Meyer Gear.—The calculations for the main valve are the same as for the simple eccentric gear described in Art. 223. We are now concerned with the calculation of the lap “*a*” of the expansion plates required for a given cut-off.

Let r = throw of main eccentric.

θ = angle of advance of main eccentric.

x = displacement of main valve from its mid position.

and r_1, θ_1, x_1 , these quantities for the expansion eccentric.

Then if α denotes any crank angle measured from the inner dead centre

$$x = r \sin (\alpha + \theta) \text{ (4), Art. 215,}$$

or if ϕ and ϕ_1 denote the angular advance of the main and of the expansion eccentric respectively (*i.e.* $\phi = 90 + \theta$), then

$$x = r \cos (\alpha + \phi) \dots \dots \dots (1)$$

$$\text{and } x_1 = r_1 \cos (\alpha + \phi_1) \dots \dots \dots (2)$$

Let δ denote the relative displacement of the expansion plates from the central position of the main valve, then

$$\delta = x - x_1 \dots \dots \dots (3)$$

$$= r \cos (\alpha + \phi) - r_1 \cos (\alpha + \phi_1) \dots \dots \dots (4)$$

Cut-off will occur for a given crank angle when the lap "a" is equal to δ. This lap will obviously be *positive* when x_1 is numerically greater than x , and negative when x_1 is numerically less than x

EXAMPLE.—The following are data from an engine fitted with a Meyer cut-off valve :—

- Connecting rod, 4 cranks long.
- Travel of main valve, 4 inches.
- Angular advance of main valve, 120°.
- Travel of expansion valve, 4 inches.
- Angular advance of expansion valve, 180°.

Find the lap "a" of the expansion valve so that cut-off may take place at 0·1, 0·2, 0·3, 0·4, 0·5 on both the head and crank ends of the piston, and deduce from these laps the best setting of the expansion valve.

The first step is to find the crank angle for the various piston positions at cut-off using (4), Art. 216, viz. :

$$x = r(\cos a - \frac{1}{2}n \sin^2 a).$$

Putting $\sin^2 a = 1 - \cos^2 a$,

this becomes
$$x = \frac{r}{2n}(\cos^2 a + 2n \cos a - 1)$$

and writing m for $\frac{x}{r}$ we have

or
$$\begin{aligned} 2mn &= \cos^2 a + 2n \cos a - 1 \\ \cos^2 a + 2n \cos a - (1 + 2mn) &= 0 \\ \cos a &= -n + \sqrt{(n^2 + 1) + 2mn}. \end{aligned}$$

In this particular example $n = 4$.

$$\therefore \cos a = -4 + \sqrt{17 + 8m} \dots \dots (5)$$

The following table may next be drawn up, using (5) :—

Piston position.		m.	cos a from (5).	a.	Crank angle.	
					Head end (Instroke).	Crank end (outstroke).
<i>Instroke.</i>	<i>Outstroke.</i>					
0·1		0·8	0·84	33°	33°	
0·2		0·6	0·675	47·5°	47·5°	
0·3		0·4	0·50	60°	60°	
0·4	0·6	0·2	0·31	72°	72°	288°
0·5	0·5	0·0	0·12	83°	83°	277°
	0·4	- 0·2	- 0·075	94·3°	94·3	265·7°
	0·3	- 0·4	- 0·28	106·3°		253·7°
	0·2	- 0·6	- 0·51	120·7°		239·3°
	0·1	- 0·8	- 0·742	136		224°

The laps (δ) may now be found using (4).

$$\begin{aligned} \delta &= r \cos (a + \phi) - r_1 \cos (a + \phi). \\ \text{In this example } r &= r_1 = 2 \text{ inches, } \phi = 120^\circ \text{ and } \phi_1 = 180^\circ. \\ \therefore \delta &= 2[\cos (a + 120) - \cos (a + 180)] \\ \delta &= 2[\cos (a + 120) + \cos a]. \end{aligned}$$

The values of the laps δ are shown in the following table:—

VALUES OF δ (INCHES).

Cut-off.	Head end.	Crank end.	Difference.
0·1	— 0·102	— 0·438	0·336
0·2	— 0·60	— 0·98	0·38
0·3	— 1·00	— 1·38	0·38
0·4	— 1·30	— 1·65	0·32
0·5	— 1·60	— 1·83	0·23

The right-hand column gives the differences between the laps required to give equal cut-off at the stated fractions of the stroke. If the expansion plates be adjusted so that the laps are 0·60 and 0·98 for the head and crank end respectively, the cut-offs at 0·1 and 0·4 will be *nearly* equalized, but those at 0·5 will be unequal. The best setting will therefore be with the laps 0·60 and 0·98.

The reader should verify the above figures graphically, using, say, the the rectangular valve diagram.

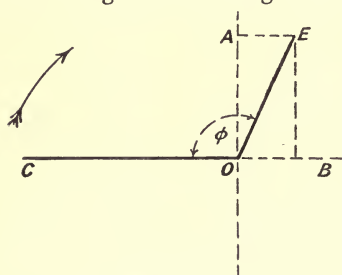

FIG. 187.

227. Resolution of the Valve Displacement Curve into Two Components at Right Angles.—

Let OE be the position of a simple eccentric whose angular advance is ϕ (Fig. 187). The actual motion of the valve may be resolved into two components, one of which is received from an imaginary eccentric OA 90° in advance of the crank and the other from an imaginary eccentric OB 180° in advance of the crank. Neglecting the effect due to the obliquity of the

eccentric rods, the displacement curve obtained from the component eccentric OA will be a sine curve whose maximum ordinate is

$$OA = r \sin \phi = Y \text{ say } \dots \dots \dots (1)$$

and the displacement for any crank angle α will be

$$x = Y \cos (\alpha + 90) = - Y \sin \alpha \dots \dots \dots (2)$$

The displacement curve obtained from the component eccentric OB will be a cosine curve whose maximum ordinate is

$$OB = r \cos \phi = X \text{ say } \dots \dots \dots (3)$$

The maximum X-component will evidently be $OB = \text{outside lap} + \text{lead}$, and the displacement for any crank angle α will be

$$x_1 = X \cos (\alpha + 180) = - X \cos \alpha \dots \dots \dots (4)$$

The total displacement of the valve will be

$$\begin{aligned} & x + x_1 \\ & = r \sin \phi \cos (\alpha + 90) + r \cos \phi \cos (\alpha + 180) \dots \dots (5) \end{aligned}$$

Writing $\phi = \theta + 90^\circ$ where θ is the angle of advance, (5) becomes

$$\begin{aligned} \text{Total displacement} &= r(\cos \theta \sin \alpha - \sin \theta \cos \alpha) \\ &= r \sin (\alpha + \theta) \dots \dots \dots (6) \end{aligned}$$

as given by (4), Art. 215.

The reader should verify this graphically by plotting (2) and (4), and, adding the ordinates together, show that the resultant curve coincides with (6).

228. Link Motions.—There are two forms of reversing gear used in practice, namely, link motions and radial valve gears. The underlying principle of both forms of motion may be explained briefly as follows:— For forward running the valve receives its motion from the eccentric E (Fig. 188), set with a certain angle of advance θ . In order to reverse the

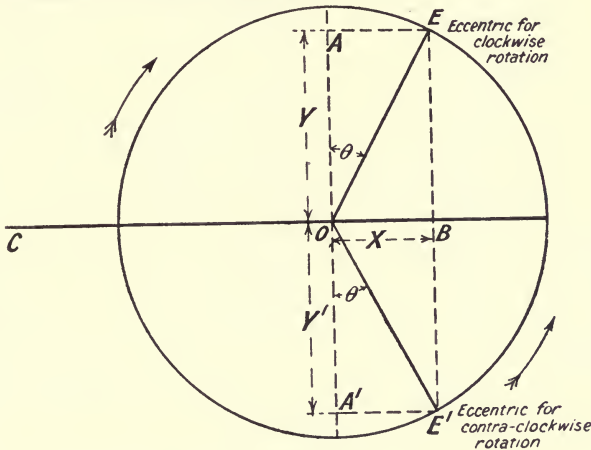

FIG. 188.

direction of rotation it is evident that the valve must be driven by a second eccentric E' having the same angle of advance. In a link motion two eccentrics are used, one for forward running and the other for reversed direction of rotation. In a radial valve gear either one or no eccentrics are used for imparting the required motion to the valve, but, in either case, for any position of the gear, a "virtual" or "equivalent" eccentric can be found which will give approximately the same motion to the valve as the actual gear itself.

For any type of reversing gear suppose E (Fig. 188) denotes the virtual eccentric for full forward gear, and E' the virtual eccentric for full backward gear, then when shifting from full forward to full backward gear, the X component of the valve's motion remains unaltered, whilst the Y component decreases, passes through zero, and then becomes negative. When in midgear, i.e. at OB, the valve's motion is that due to the X component only, the half-travel of the valve being the outside lap + lead.

A detailed analysis of the various reversing gears is beyond the scope of this book, and it is only proposed to give here an approximate solution to the most common types.¹

¹ For a detailed analysis of these motions, see Prof. W. E. Dalby's book on "Valves and Valve Gear Mechanisms," Edward Arnold.

229. Stephenson's Link Motion.—Fig. 189 shows the centre line diagram of this link motion with open rods. It consists essentially of a curved slotted link AB concave *towards* the crankshaft O and suspended by a lever from the "weigh-bar" shaft F in such a manner that it may be raised or lowered as required. A block R attached to the valve rod is free to slide in the slotted link AB, and the eccentric rods *aA* and *bB* are pinned to the link as shown. When the link AB is lowered into one extreme position the block R is at the end of the slot close to A, and the

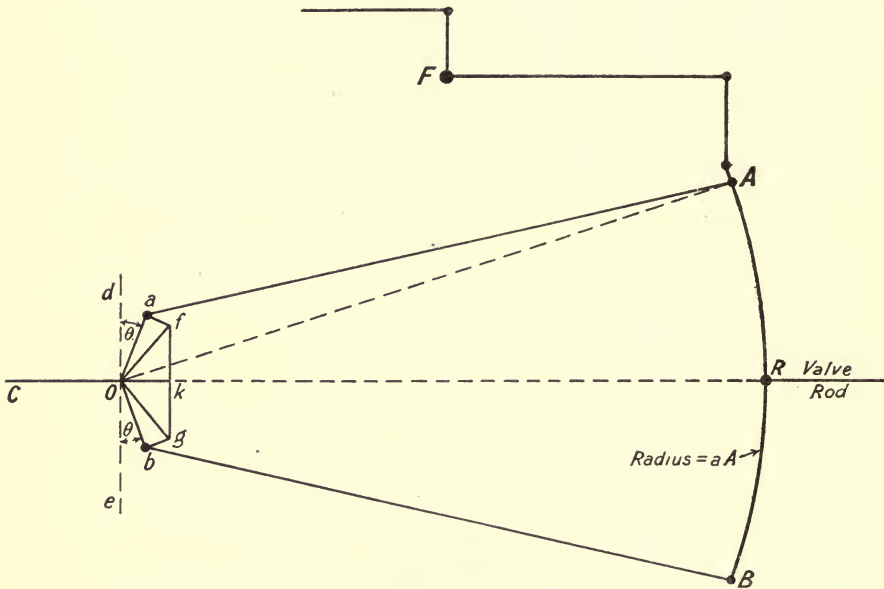

FIG. 189.

valve receives its motion *principally* from the forward eccentric *a*, this position being known as full forward gear. When the link AB is raised to its other extreme position, the valve receives its motion principally from the backward eccentric *b*, this position being known as full backward gear. When the block R is half way between A and B (as in Fig. 189) the motion is in mid-gear; for forward running R may be in any position between A and mid-gear, and for backward running it may be in any position between B and mid-gear.

By setting the link AB in any intermediate position the valve receives a motion very nearly the same as that which would be given by a single eccentric of shorter "throw" and of greater angular advance, and the effect is to give a distribution of steam in which cut-off is earlier. The mechanism thus serves to adjust the work done to the demand, in addition to giving reversal.

Virtual or Equivalent Eccentric.—In full forward gear, when A is lowered to R (Fig. 189), the equivalent eccentric is *oa*, its angle of advance being $\angle doa$. In full backward gear, when B is raised to R, the equivalent eccentric is *ob*, its angle of advance being $\angle eob$, which also equals $\angle doa$.

Suppose now we wish to find the equivalent eccentric for mid-gear (the position shown in Fig. 189). Make $\angle aof = \angle bog = \angle AOR$, and draw af and bg at right angles to oa and ob respectively; join fg and bisect it in k , then the equivalent eccentric for mid-gear is ok with an angle of advance of $\angle dok = 90^\circ$.

For crossed rods the required construction is similar, the only difference being to set of out *behind* oa and og behind ob , the angles $\angle aof$ and bog both being equal to $\angle AOR$ as before. The construction for open and for crossed rods is given on a larger scale in Fig. 190.

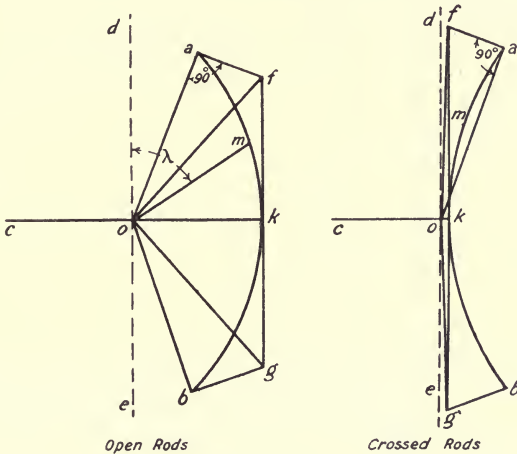

FIG. 190.

For any intermediate position of the gear draw an arc of a circle passing through a , k , and b and divide the arc in m in the same proportion as R divides AB , i.e. make $\frac{am}{mb} = \frac{AR}{RB}$. Then om is the equivalent eccentric and $\angle dom$ its angle of advance λ .

Macfarlane Gray's Construction for Equivalent Eccentric.—As in Fig. 189, draw the centre line diagram for the gear in its required position, with the crank in the dead centre and away from the cylinder. Draw an arc of a circle passing through a and b (Fig. 191) and of radius equal to

$$\frac{ab \times aA}{2AB}$$

Take a point m in the arc ab such that

$$\frac{am}{mb} = \frac{AR}{RB}$$

then om is the "throw" of the equivalent eccentric and angle $\angle dom$ its angle of advance.

For crossed rods the arc ab must be drawn convex towards the crankshaft as shown in Fig. 192. Having obtained the equivalent eccentric for

a given position of the gear, the rectangular, or the Reuleaux, or any other valve diagram may be drawn.

For an accurate solution of the link motion the valve displacement

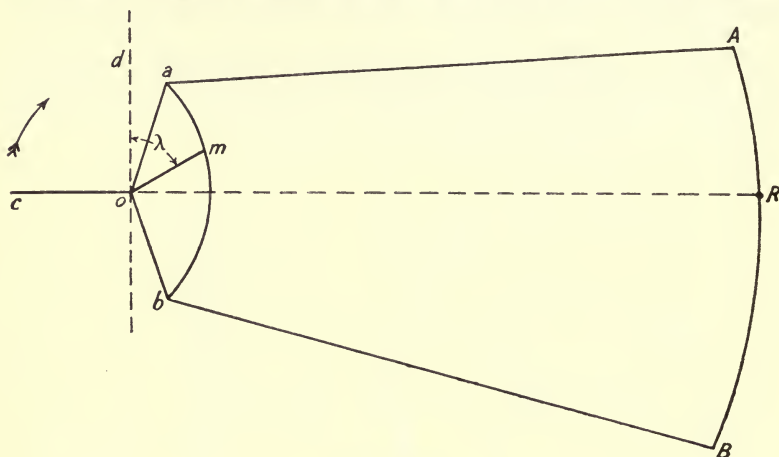

FIG. 191.

curve must be plotted for a complete revolution of the crank-shaft. In order to do this the gear should be drawn in *full size* for, say, twenty-four different positions of the crank and the displacement of the block R (and therefore of the valve) scaled off.¹

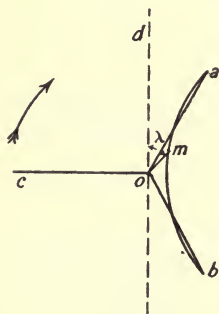

FIG. 192.

It should be noted that in passing from full forward to backward gear the block R will be moved slightly, with the result that with this link motion a variable lead is given. This is because the slotted link AB is, for convenience in manufacture, curved to the arc of a circle of radius equal to the common length of the eccentric rods instead of being made to the proper geometrical curve, which would give constant lead, *i.e.* no motion to R when the gear is moved. This constitutes the only drawback to the Stephenson link motion, but its simplicity, combined with the fairly good steam distribution obtained, results in its extensive use. The

reader should verify that with open rods the lead *increases* slightly towards mid-gear, but with crossed rods the lead *decreases* towards mid-gear.

230. Gooch Link Motion.—In this motion the lead remains constant for all positions of the gear. Fig. 193 shows a centre line diagram of this link motion. The centre D of the slotted link AB is constrained to move in an arc of a circle about the fixed fulcrum E, being supported by the link DE. The valve rod is jointed at V and is supported by the link FK; the block R is raised or lowered in the link AB by turning the weigh-bar shaft about its fixed axis G by means of the reversing lever H.

¹ For a complete discussion, see Dalby's "Valves and Valve Gear Mechanisms."

The valve displacement curve for any position of the gear may be approximately obtained by finding the equivalent eccentric, the construction being similar to that given for the Stephenson link motion (Fig. 190) for both open and for crossed rods. Find the points f , k , and g in exactly the

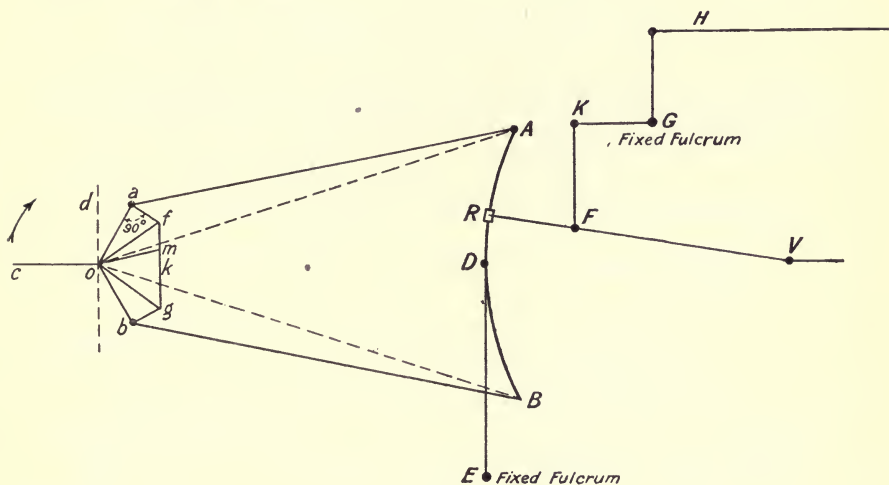

FIG. 193.

same way as for the Stephenson motion. Join fg and divide it in the same proportion as R divides the link AB , *i.e.* make $\frac{fm}{mg} = \frac{AR}{RB}$, then om is the

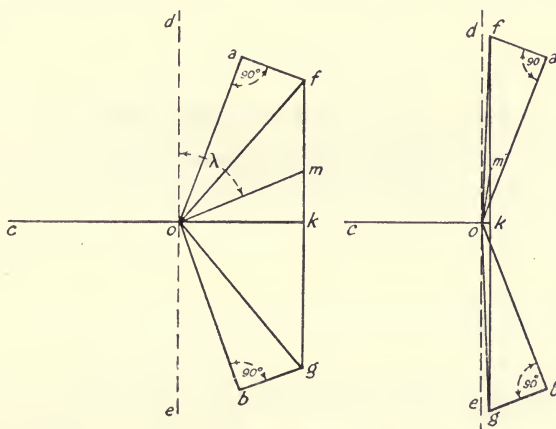

FIG. 194.

equivalent eccentric and $\angle dom$ its angle of advance (λ). Fig. 194 shows the construction for both open and crossed rods. The Gooch motion gives a better steam distribution than Stephenson's, but is a little more complicated and not extensively used in modern practice.

231. Analytical Method—Approximate Theory for Stephenson's Motion.—Referring to Fig. 195

Let l = length of eccentric rods aA and bB
 r = throw of eccentrics = $oa = ob$
 c = half the length of the curved link AB
 u = distance between R and D .

Assume A to move with simple harmonic motion along AO , and B to move with simple harmonic motion along BO . Then the displacement of A from its central position is

$$r \cos \delta oa = r \cos (\gamma + \alpha + \phi) \dots \dots \dots (1)$$

The corresponding displacement of R relative to point B is

$$\frac{RB}{AB} \times r \cos \delta oa = \frac{c + u}{2c} \cdot r \cos (\gamma + \alpha + \phi) \text{ [see Art. 239]} (2)$$

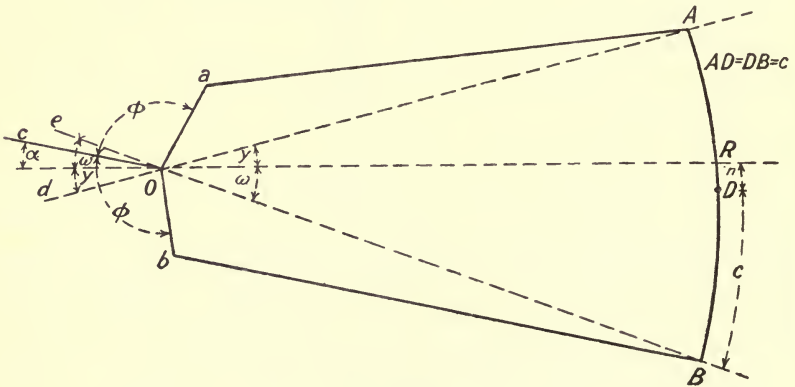

FIG. 195.

Also, the displacement of B from its central position is

$$r \cos \delta oe = r \cos (\phi - \alpha + \omega) \dots \dots \dots (3)$$

The corresponding displacement of R relative to point A is

$$\frac{AR}{AB} \times r \cos \delta oe = \frac{c - u}{2c} \cdot r \cos (\phi - \alpha + \omega) \text{ [see Art. 239]} (4)$$

Hence the displacement (x) of R , and therefore of the valve, from its mid-position is the sum of (2) and (4), namely

$$x = r \cdot \frac{c + u}{2c} \cos [(\phi + \gamma) + \alpha] + r \cdot \frac{c - u}{2c} \cos [(\phi + \omega) - \alpha] (5)$$

Expanding $\cos [(\phi + \gamma) + \alpha]$ and $\cos [(\phi + \omega) - \alpha]$ (5) becomes

$$x = r \cos \alpha \left\{ \frac{c + u}{2c} \cos (\phi + \gamma) + \frac{c - u}{2c} \cos (\phi + \omega) \right\} + r \sin \alpha \left\{ \frac{c - u}{2c} \sin (\phi + \omega) - \frac{c + u}{2c} \sin (\phi + \gamma) \right\} \dots (6)$$

Expanding $\cos(\phi + \gamma)$, $\cos(\phi + \omega)$, $\sin(\phi + \omega)$, and $\sin(\phi + \gamma)$, this becomes

$$x = r \cos \alpha \left\{ \frac{c+u}{2c} (\cos \phi \cos \gamma - \sin \phi \sin \gamma) + \frac{c-u}{2c} (\cos \phi \cos \omega - \sin \phi \sin \omega) \right\} \\ + r \sin \alpha \left\{ \frac{c-u}{2c} (\sin \phi \cos \omega + \cos \phi \sin \omega) - \frac{c+u}{2c} \right. \\ \left. \times (\sin \phi \cos \gamma + \cos \phi \sin \gamma) \right\} \dots \dots \dots (7)$$

Since γ and ω are small we may write $\cos \gamma = \cos \omega = 1$, and

$$\sin \gamma = \frac{AR}{AO} = \frac{c-u}{l}, \text{ and } \sin \omega = \frac{RB}{OB} = \frac{c+u}{l}, \text{ hence we have}$$

$$\therefore x = r \cos \alpha \left\{ \cos \phi - \frac{c^2 - u^2}{cl} \sin \phi \right\} - r \sin \alpha \left\{ \frac{u}{c} \sin \phi \right\} \quad (8)$$

$$= X \cos \alpha - Y \sin \alpha \dots \dots \dots (9)$$

where $X = r \left\{ \cos \phi - \frac{c^2 - u^2}{cl} \sin \phi \right\}$ and $Y = r \left\{ \frac{u}{c} \sin \phi \right\} \dots \dots (10)$

If now ρ be the "throw" of the equivalent eccentric and λ its angular advance, we may write

$$X = \rho \cos \lambda \text{ and } Y = \rho \sin \lambda \dots \dots \dots (11)$$

and $\tan \lambda = \frac{Y}{X} \dots \dots \dots (12)$

When $u = c$, i.e. when R is at A, $X = r \cos \phi$, and $Y = r \sin \phi$, the equivalent eccentric is therefore oa . When $u = -c$, i.e. when R is at B, the equivalent eccentric is ob . When $u = 0$, i.e. in mid gear

$$X = r \left\{ \cos \phi - \frac{c}{l} \sin \phi \right\} \quad Y = 0$$

$$\tan \lambda = \frac{Y}{X} = 0$$

$\therefore \lambda = 0$ or 180° according to the arrangement of the gear.

Gooch Motion.—The method is the same as for Stephenson's motion down to (7). Substituting in (7) $\sin \gamma = \sin \omega = \frac{c}{l}$, and $\cos \gamma = \cos \omega = 1$ it reduces to

$$x = r \cos \alpha \left\{ \cos \phi - \frac{c}{l} \sin \phi \right\} - r \sin \alpha \left\{ \frac{u}{l} \cos \phi + \frac{u}{c} \sin \phi \right\} \dots \dots (13)$$

$= X \cos \alpha - Y \sin \alpha$, where

$$X = r \left\{ \cos \phi - \frac{c}{l} \sin \phi \right\} = \rho \cos \lambda \text{ and } Y = r \left\{ \frac{u}{l} \cos \phi + \frac{u}{c} \sin \phi \right\} = \rho \sin \lambda \quad (14)$$

232. The Allan Link Motion.—In this motion the slotted link AB (Fig. 196) is straight and is suspended from the weigh-bar shaft by the link AK. The arms HK and HG form part of the weigh-bar shaft and turn with it about the fixed fulcrum H. The valve rod is jointed at V and supported by the link FG. On turning KHG in a contra-

clockwise direction by pulling the reversing lever *L*, the link *AB* is lowered and the block *R* simultaneously raised. The motion of *AB* from full forward to full backward gear is therefore much less than in the case of the Stephenson motion, and the weight of the link *AB* and the

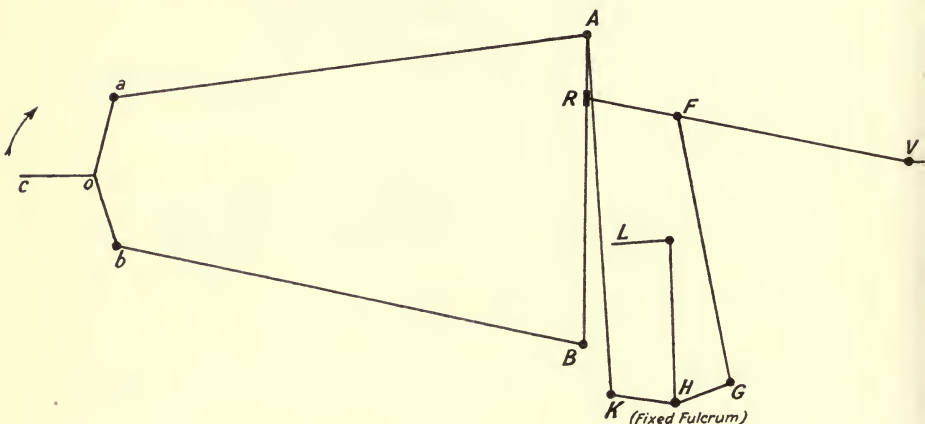

FIG. 196.

eccentric rods can be made to balance that of the rod *RV* by giving suitable lengths to *HK* and *HG*. The solution to this motion is rather more intricate than either Stephenson's or Gooch's.¹

233. Hackworth's Radial Valve Gear.—A centre line diagram of this gear is given in Fig. 197. A single eccentric *E* is used diametrically opposite to the crank *C*. The extremity *F* of the link *FE* is constrained to move along the guide bar or slotted link *AB*, and the valve *V* receives its motion from point *G* through the rod *VG*. The mean position of the link *FE* is arranged to be perpendicular to the line of stroke of the piston *P*, and the guide bar *AB* can be turned in a contra-clockwise direction (thus altering the angle θ), so that it may be made to occupy the dotted or any intermediate position. By this means the travel of the valve can be varied, and the engine reversed when *AB* has passed through the position *DO*, *i.e.* when θ changes from positive to negative. As the crank rotates the point *G* describes the full line oval in space. Hence to find the correct valve displacement, it is necessary to plot in the gear for a number of crank angles and scale off the displacement of *V*. When the bar *AB* is in, say, the dotted position, *G* describes the dotted oval and the engine runs reversed.

Equivalent Eccentric.—An approximate solution may be obtained by finding the equivalent eccentric which, driving through *GV*, will give an approximation to the actual motion of the valve. A simple graphical construction for this purpose is the following: Set off *OC* (Fig. 198) to represent the position and length of the crank when on the inner dead centre, and *OE* the position and "throw" of the eccentric. Draw *OB*

¹ For further details, see Dalby's "Valves and Valve Gear Mechanisms."

perpendicular to CE, and EB inclined θ to OE. Divide OE in m_2 such that

$$\frac{Om_2}{OE} = \frac{FG}{FE} \text{ (Fig. 197)}$$

and erect the perpendicular mm_2 . Then for this position of the guide bar Om represents the equivalent eccentric and $\angle BOm$ its angle of

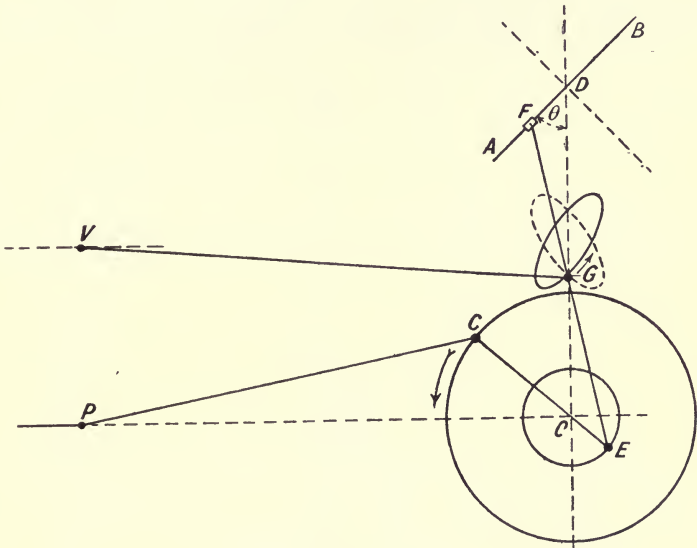

FIG. 197.

advance. If the angle $\angle OEB$ (θ) is the extreme value of the inclination of the slotted bar AB (Fig. 197), Om will be the equivalent eccentric for full forward gear, forward running being understood to be in the direction of the arrow in Fig. 197. For full backward gear set out $\angle OEB' = \angle OEB$, then Om' will be the equivalent eccentric for full backward gear, its angle of advance being $\angle B'Om'$.

When the motion is in mid-gear, *i.e.* when $\theta = 0^\circ$, the equivalent eccentric is Om_2 , its angle of advance being $\angle BOm_2 = 90^\circ$. For any intermediate position of the gear set off $\angle OEm_1'$, equal to the particular value of θ , and Om_1' will be the equivalent eccentric. It should be noticed that for all positions of the gear, *i.e.* for all possible values of θ , the displacement of the valve from its mid-position when the crank is on the dead centre is equal to Om_2 , or in other words equal to the *outside lap* plus the *lead* of the valves.

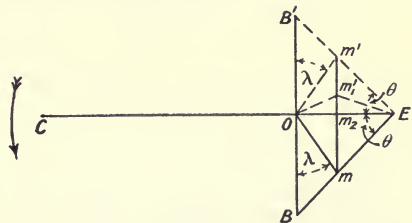

FIG. 198.

234. Marshall's Valve Gear.—In this gear the eccentric OE (Fig. 199) is set at the same angle as the crank OC, and the point G describes an arc of a circle having L as centre. For any position of the gear L is a fixed centre. To reverse the engine, the centre L is swung over towards the left about the fixed centre M, so that L may occupy any position on an arc of a circle of radius ML and centre M. The motion is shown in full forward gear in Fig. 199, the dotted position ML' being for full backward gear. As the crank rotates, the point G swings to and fro along a small arc having L as centre, and the point F describes

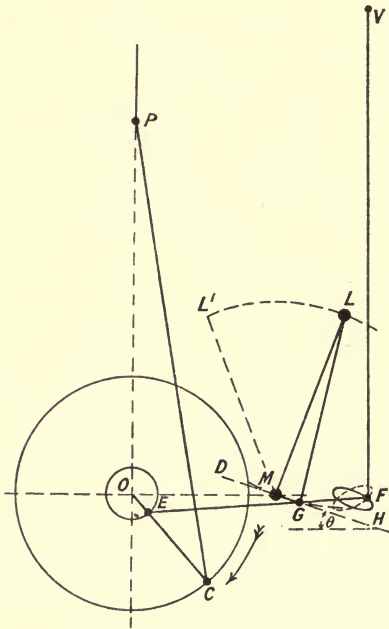

FIG. 199.

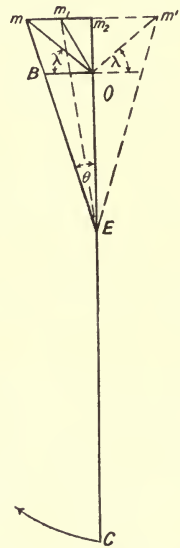

FIG. 200.

the full line oval curve. When the centre L is shifted over into its other extreme position, the point F describes the dotted oval. The mean position of the link EF is perpendicular to OP (as in Hackworth's gear), and for all positions of the gear its inclination to OF is very small.

Equivalent Eccentric.—To obtain an approximate solution we may proceed as for the Hackworth gear. First find for any position of the gear the two extreme positions of the point G. Since the length of the arc described by G is small it may be replaced by a straight line DH, whose inclination θ to OF is the same as the mean inclination of the arc.

Set off OC (Fig. 200) to represent the crank, and OE the eccentric when the crank is on either dead centre (Fig. 200 shows it when the piston is at the bottom of its stroke, the crank being on the outer dead

centre). Draw OB perpendicular to OC, and EB making angle θ with EO. Produce EO to m_2 making

$$\frac{OE}{Em_2} = \frac{EG}{EF} \quad (\text{Fig. 199})$$

and draw mm_2 perpendicular to Om_2 . Then Om represents the equivalent eccentric, and $\angle COM$ its angular advance, or $\angle BOM$ its angle of advance.

When the motion is in midgear, $\theta = 0^\circ$, and Om_2 is the equivalent eccentric, its angle of advance being $\angle BOM_2 = 90^\circ$. For any intermediate position of the gear set off $\angle OEM_1$, equal to the particular value of θ and Om_1 , will be the equivalent eccentric. When θ is negative, *i.e.* for reversed running, the construction is shown dotted. For all positions of the gear the displacement of the valve from its mid-position is Om_2 , which is equal to the *lap* plus the *lead* of the valve, being in this respect similar to the other link motions previously considered.

235. Joy's Valve Gear.—A centre line diagram of this gear is shown in Fig. 201. For any position of the gear G_1 and G_2 are fixed axes, and

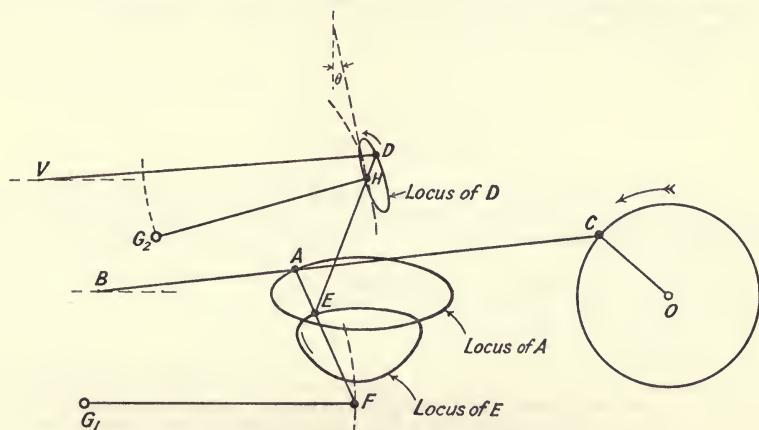

FIG. 201.

F describes an arc of a circle whose centre is at G_1 , whilst H describes an arc whose centre is at G_2 . Points A, E, and D describe the oval curves shown. The valve V receives its motion from D through the rod DV, hence from the locus of D the corresponding valve displacements may be found. The engine is reversed by shifting the axis G_2 along the arc shown dotted. When reversed the path of E is unaltered, but the paths of H and D are inclined in the opposite direction to the vertical.

Equivalent Eccentric.—First find the two extreme positions of the point H; since the length of the arc described by H is small, it may be replaced by a straight line (shown dotted in Fig. 201), whose inclination θ to the vertical is the same as the average inclination of the arc.

Set off OC (Fig. 202) to represent the position of the crank on the

dead centre, *i.e.* when the piston is at the head end of the cylinder, make OE_1 equal to half the horizontal displacement of point E and OE_2 , equal to half the vertical displacement of E. Draw OB 90° in front of the crank, and make angle $OE_2B = \theta$. Produce E_1O to A, making

$$\frac{E_1O}{E_1A} = \frac{EH}{ED} \text{ (Fig. 201).}$$

Join E_1B and produce it to cut the perpendicular from A in point m . Then Om is the equivalent eccentric and $\angle COM$ its angular advance, or $\angle BOM$ its angle of advance, λ . For midgear θ is zero, the equivalent

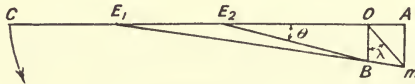

FIG. 202.

eccentric is OA , its angle of advance being 90° . For any intermediate position of the gear, the equivalent eccentric may be found by repeating the above construction, the angle θ depending upon the position of G_2 (Fig. 201).¹

EXAMPLES XVIII.

1. The travel of a slide valve is 5 inches, lead at head end 0.25 inch, cut-off at 0.7 , and release at 0.95 of the stroke for both ends. If the connecting rod is 4 cranks long, find (a) outside and inside laps; (b) angle of advance; (c) maximum openings to steam; (d) lead at crank end.
2. Neglecting the obliquity of the connecting rod, find the angle of advance, travel, and steam lap, so that cut-off may take place at 0.6 of the stroke, and so that the maximum opening to steam is 1 inch and the lead 0.1 inch.
3. Solve Question 2, if the connecting rod is 3.5 cranks long.
4. The travel of a slide valve is 4 inches, lead at both ends 0.125 inch, cut-off at head end 0.6 stroke, release at both ends 0.96 stroke. Find: (a) outside and inside laps for both ends; (b) cut-off on crank end; (c) angle of advance. Connecting rod 4 cranks long.
5. In a steam engine the connecting rod is 4 cranks long, and the displacement of the slide valve is given by the equation

$$x = 2.6 \sin(a + 32^\circ) + 0.2 \sin(2a + 105^\circ)$$

Draw a rectangular valve diagram and find the two outside laps, in order that cut-off may take place at 0.7 of the stroke at both ends of the cylinder.

6. An engine, with a cylinder 21 inches diameter and 36 inches stroke, runs at 72 revolutions per minute. It is fitted with an ordinary single-ported slide valve, and the point of cut-off is to be 0.64 stroke for both ends of the cylinder. The width of the ports (in plan) is 18.5 inches, and the steam speeds allowed are 120 feet per second for admission and 90 feet per second for exhaust. Draw the valve diagram and obtain the valve travel, maximum openings to steam and exhaust, leads, outside and inside laps, to give a reasonable indicator card. Connecting rod, 5 cranks. (L.U.)

NOTE.—Assume a lead (head end) of 0.25 inch.

7. In a Meyer valve gear the travel of the main valve is 3.5 inches, and its angle of advance 30° . The travel of the expansion valve is 3.5 inches, and its angle of advance 90° . Find the radius and angle of advance of the equivalent eccentric, and the "lap" of the expansion plate (a) for a cut-off at 0.2 stroke. Neglect the obliquity of the connecting rod.

¹ For further details, see Dalby's "Valve Gears and Valve Gear Mechanisms."

8. The following are data from an engine fitted with a Meyer valve :—

Connecting rod, 4 cranks long.

Travel of main valve, 3.5 inches.

Angle of advance of main valve, 30° .

Travel of expansion valve, 3.5 inches.

Angle of advance of expansion valve, 90° .

Find (using a graphical construction) the lap "a" of the expansion valve, so that cut-off may take place at 0.2, 0.3, 0.4, 0.5, and 0.6 on both sides of the piston, and deduce from these laps the best setting of the expansion valve.

9. Solve Question 8 analytically.

10. A Meyer valve gear is to be capable of varying the mean cut-off from 0.1 to 0.6 of the stroke; connecting rod, 4 cranks. The main valve is to give a maximum opening to steam of 1.375 inches, and, if acting alone, would cut-off at 0.75 of the stroke at the head end of the cylinder. The lead of the main valve is to be 0.25 inch. Find :—

(a) Travel of main valve, its angle of advance, and outside lap.

(b) If the travel of the expansion valve is 1.1 times that of the main valve, and its angle of advance is 90° , find its lap "a" at the above fractions of the stroke.

(c) If the width of the steam ports in the cylinder is 1.75 inches, find the width of the narrowest expansion plates required.

11. In a Stephenson's Link Motion the "throw" of each eccentric is 3 inches, angle of advance 20° , length of slotted link 20 inches, length of each eccentric rod 60 inches. Find the equivalent eccentric (a) when in full gear; (b) when in mid gear.

12. The displacement of the valve operated by a Stephenson Link Motion is approximately

$$x = X \cos \alpha - Y \sin \alpha,$$

in which X and Y are constants, having the values

$$X = r(\cos \phi - 0.11 \sin \phi)$$

$$Y = 0.55r \sin \phi$$

r is the radius of eccentricity of each eccentric sheave, and ϕ is the angle between the crank and the eccentric radius of each sheave.

Find values of r and ϕ which will secure a cut-off of 76 per cent. of the stroke, a lead of 0.1 inch, and a maximum opening for steam of 1 inch. Neglect the obliquity of the connecting rod.

13. In the Hackworth radial valve gear, shown in Fig. 197, $OC = 1.3'$; $CP = 4.2'$; $OE = 0.5'$; $OD = 3.45'$; $\theta = 45^\circ$; $EF = 3.48'$; $EG = 1.84'$; $GV = 5.06'$. Distance between strokes of P and V = $1.83'$. Plot the gear when the crank angle POC is 60° , and find

(a) Travel of valve V.

(b) Angle of advance of equivalent eccentric actuating V.

Find also the equivalent eccentric for mid gear, *i.e.* when $\theta = 0^\circ$.

14. In the Marshall radial valve gear, shown in Fig. 199, $OC = 1.2'$; $CP = 4.78'$; $OE = 0.25'$; $OM = 1.5'$ (O and M being on the same horizontal line); inclination of ML to the vertical, 20° ; $ML = LG = 2'$; $EG = 1.6'$; $EF = 2.3'$. Distance between strokes of P and V = $2.4'$. Plot the gear when the crank angle POC is 135° , and find the equivalent eccentric actuating V.

15. In the Joy valve gear, shown in Fig. 201, $OC = 1' - 1''$; $CA = 4' - 1''$; $AB = 2' - 1''$; $AE = 7.25''$; $EF = 1' - 0.2''$; $G_1F = 2' - 4''$; perpendicular distance of G_1 from BO = $1' - 1.4''$; horizontal distance of G_1 from O = $6' - 6''$. Distance between strokes of B and V = $1' - 2.2''$; $ED = 2'$; $DH = 3''$; $VD = 3' - 7.2''$; $G_2H = 2'$; perpendicular distance of G_2 from BO = $7''$; horizontal distance of G_2 from O = $6'$. Find :—

(a) Horizontal displacement of E.

(b) Vertical displacement of E.

(c) Half travel of valve and angle of advance of equivalent eccentric.

CHAPTER XIX

TWISTING MOMENT DIAGRAMS

236. Twisting Moment for any Crank Angle.—

Let P = effective force on the piston in pounds (obtained as explained in Art. 283).

Q = thrust along the connecting rod in pounds.

θ = crank angle measured from the inner dead centre.

ϕ = inclination of connecting rod to the line of stroke.

r = length of crank in feet, *i.e.* half the stroke of the piston.

Then, referring to Fig. 203

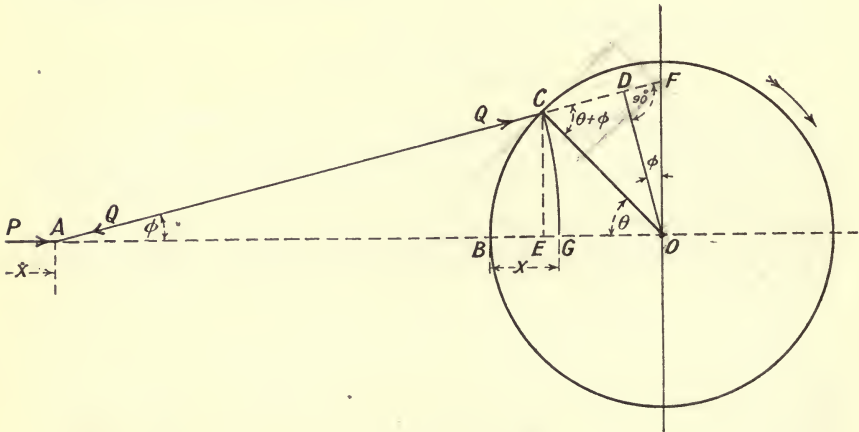

FIG 203.

Twisting moment $T = Q \times$ perpendicular distance OD .

Now $Q = P \sec \phi$
 $\therefore T = P \sec \phi \times OD$

But $OF = OD \sec \phi$
 $\therefore = P \times OF$ pound feet (1)

The twisting moment may also be expressed as follows:—

$$\begin{aligned}
 T &= Q \times OD \\
 &= P \sec \phi \times OC \sin \angle OCD \\
 &= P \sec \phi \times r \sin (\theta + \phi)
 \end{aligned}$$

or $T = Pr \times \frac{\sin (\theta + \phi)}{\cos \phi}$ pound feet (2)

After the value of P has been found for any crank angle θ , either (1) or (2) may be used in order to calculate the twisting moment.

237. Inertia of the Reciprocating Parts—Acceleration of the Piston.—In order to find the effective force P, on the piston, we must know the acceleration of the piston for any position of the crank. This may be obtained analytically as follows:—

Let ω = angular velocity of the crank in radians per second (assumed constant).

l = length of connecting rod.

$$n = \frac{l}{r}$$

x = displacement of the piston from the end of its stroke.

Then, since $AG = AC = l$ (Fig. 203)

$$\begin{aligned} x &= BE + EG, \text{ where } CE \text{ is perpendicular to } AO. \\ &= r(1 - \cos \theta) + l(1 - \cos \phi) \dots \dots \dots (1) \end{aligned}$$

Also $CE = l \sin \phi = r \sin \theta$.

$$\therefore \sin \phi = \frac{r}{l} \sin \theta = \frac{1}{n} \sin \theta \dots \dots \dots (2)$$

$$\text{and } \cos \phi = \sqrt{1 - \sin^2 \phi} = \frac{1}{n} \sqrt{n^2 - \sin^2 \theta} \dots \dots (3)$$

Substituting (3) in (1), we have

$$x = r(1 - \cos \theta) + l(1 - \frac{1}{n} \sqrt{n^2 - \sin^2 \theta}) \dots \dots (4)$$

Differentiating (4), we find the velocity of the piston $v = \frac{dx}{dt}$

$$v = \frac{dx}{dt} = \frac{d\theta}{dt} \cdot \frac{dx}{d\theta} = \omega \frac{dx}{d\theta}$$

and
$$\frac{dx}{dt} = \omega r \left(\sin \theta + \frac{\sin \theta \cos \theta}{\sqrt{n^2 - \sin^2 \theta}} \right) \dots \dots \dots (5)$$

or
$$v = \omega r \left(\sin \theta + \frac{\sin 2\theta}{2\sqrt{n^2 - \sin^2 \theta}} \right) \dots \dots \dots (5a)$$

Neglecting $\sin^2 \theta$, an approximate expression for the velocity is, from (5a),

$$v = \omega r \left(\sin \theta + \frac{\sin 2\theta}{2n} \right) \dots \dots \dots (6)$$

Differentiating (5), we find the acceleration of the piston $\frac{dv}{dt}$ or $\frac{d^2x}{dt^2}$

$$\frac{d^2x}{dt^2} = \frac{dv}{dt} = \frac{d\theta}{dt} \cdot \frac{dv}{d\theta} = \omega \frac{dv}{d\theta}$$

and
$$\therefore \frac{d^2x}{dt^2} = \omega^2 r \left[\cos \theta + \frac{n^2 \cos 2\theta + \sin^4 \theta}{(n^2 - \sin^2 \theta)^{\frac{3}{2}}} \right] \dots \dots (7)$$

Neglecting $\sin^2 \theta$ and $\sin^4 \theta$, an approximate expression is

$$\frac{d^2x}{dt^2} = \omega^2 r \left(\cos \theta + \frac{1}{n} \cos 2\theta \right) \dots \dots (8)$$

which is accurate enough for practical purposes except when n is small.

If the obliquity of the connecting rod be neglected the piston executes a simple harmonic motion, and its acceleration is $\omega^2 r \cos \theta = \omega^2 \cdot OE$.

The approximate expressions (6) and (8) may also be deduced directly as follows:—

As before, $x = BE + EG$ (Fig. 203)

Now $EG \times (AG + AE) = (CE)^2$

$$\therefore EG = \frac{CE^2}{AG + AE}$$

But $CE = r \sin \theta$, and $AG = AC = l$, and writing $AE = AG$, we have

$$EG = \frac{CE^2}{2AG} = \frac{r^2 \sin^2 \theta}{2l}$$

$$\therefore x = r(1 - \cos \theta) + \frac{r^2}{2l} \sin^2 \theta \text{ approximately}$$

$$= r \left\{ (1 - \cos \theta) + \frac{1}{2n} \sin^2 \theta \right\} \text{ approximately} \dots (9)$$

$$\therefore v = \frac{dx}{dt} = \omega r \left(\sin \theta + \frac{\sin 2\theta}{2n} \right) \text{ as above}$$

and $\frac{d^2x}{dt^2} = \omega^2 r \left(\cos \theta + \frac{1}{n} \cos 2\theta \right) \text{ as above.}$

Graphical Method.—Klein's construction may be conveniently used for finding the acceleration of the piston. Draw the centre lines of crank OC and connecting rod AC, producing the centre line of the rod (if necessary) to cut the perpendicular to the line of stroke through O in point F (Fig. 204). With C as centre, and radius CF, describe a circle, and draw another circle on AC with AC as diameter. Draw the common chord to these circles, producing it if necessary to cut the line of stroke in point B. Then OB represents, to scale, the acceleration of the piston when the crank is at C. If the length of OC represents the centripetal acceleration ($\omega^2 r$) of the crank-pin, OB represents *to the same scale* the acceleration of the piston, or, in other words, the acceleration of the piston is $\omega^2 \cdot OB$.

The angular acceleration of the connecting rod is proportional to DB being equal to $\omega^2 \cdot \frac{DB}{AC}$.

Accelerations at the ends of the stroke.—At the inner dead centre where $\theta = 0$, we find from either (7) or (8)

$$\frac{d^2x}{dt^2} = \omega^2 r \left(1 + \frac{1}{n} \right) \dots \dots (10)$$

Similarly at the outer dead centre where $\theta = 180^\circ$

$$\frac{d^2x}{dt^2} = \omega^2 r \left(1 - \frac{1}{n} \right) \dots \dots (11)$$

Position of the piston when its acceleration is zero.—Equating (7) to zero, we find

$$\cos \theta + \frac{n^2 \cos 2\theta + \sin^4 \theta}{(n^2 - \sin^2 \theta)^{\frac{3}{2}}} = 0$$

$$\cos \theta (n^2 - \sin^2 \theta)^{\frac{3}{2}} = -(n^2 \cos 2\theta + \sin^4 \theta)$$

Squaring both sides of this equation, we get

$$\cos^2 \theta (n^2 - \sin^2 \theta)^3 = (n^2 \cos 2\theta + \sin^4 \theta)^2$$

which reduces to

$$\sin^6 \theta - n^2 \sin^4 \theta - n^4 \sin^2 \theta + n^4 = 0 \quad \dots \quad (12)$$

a cubic equation for $\sin^2 \theta$. The value of θ given by this equation is very nearly equal to that given by $\theta = \tan^{-1} n$, which represents the crank

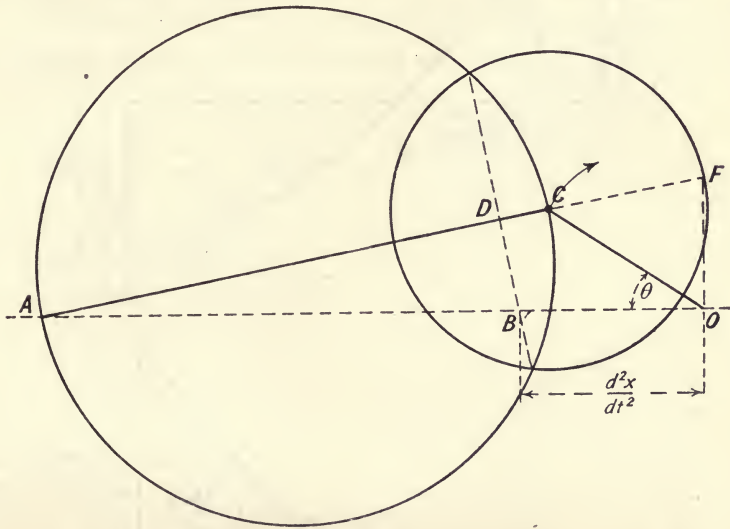

FIG. 204.

angle when the connecting rod is perpendicular to the crank, *i.e.* when the angle $\angle ACO$ (Fig. 203) $= 90^\circ$. For example, when $n = 4$, the true value of θ from (12) is $76^\circ 43'$, whilst the approximate value $\theta = \tan^{-1} 4$ is $75^\circ 58'$; when $n = 8$ (12) gives $\theta = 82^\circ 59'$, whilst $\tan^{-1} 8 = 82^\circ 52'$.

The error made in assuming the piston to have zero acceleration when the connecting rod and crank are at right angles, *i.e.* when $\theta = \tan^{-1} n$, is therefore negligibly small in practice. Taking this value of θ and substituting in (9) we have the piston displacement

$$\begin{aligned} x &= r \left\{ (1 - \cos \theta) + \frac{1}{2n} \sin^2 \theta \right\} \\ &= r \left\{ 1 - \frac{1}{\sqrt{1+n^2}} + \frac{n}{2(1+n^2)} \right\} \\ &= \frac{s}{2} \left\{ 1 - \frac{1}{\sqrt{1+n^2}} + \frac{n}{2(1+n^2)} \right\} \quad \dots \quad (13) \end{aligned}$$

(where s = the stroke of the piston), which may be written

$$x = \left\{ 1 + n - \sqrt{1 + n^2} \right\} \frac{s}{2} \dots \dots \dots (14)$$

Eq. (14) will therefore give the position of the piston from the inner

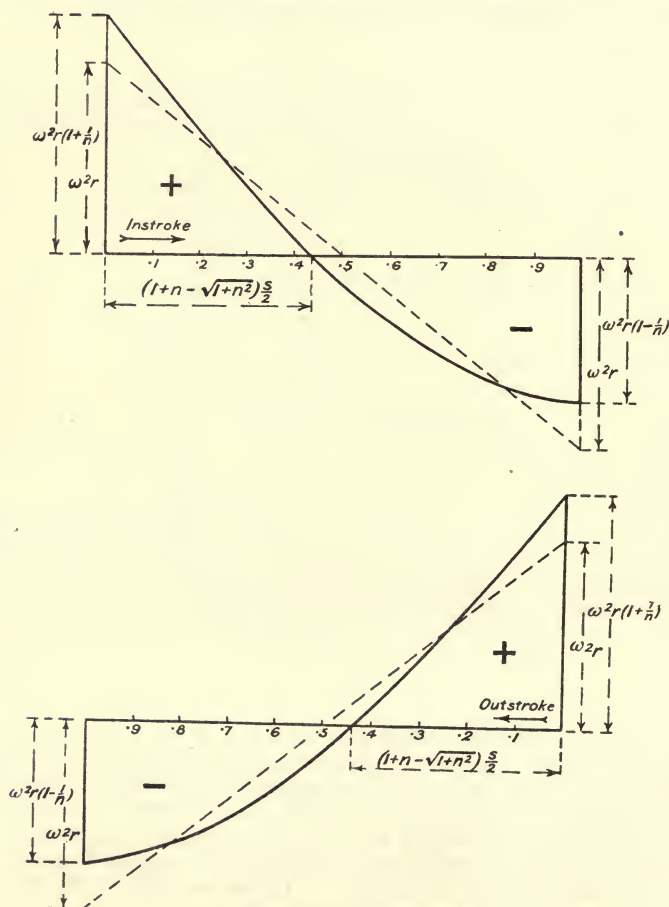

FIG. 205.

dead centre position when its acceleration is zero, quite accurately enough for all practical purposes.

Acceleration curves.—The curves shown in Fig. 205 have been drawn for $n = 4$, using the equations (8) and (14). The results of the calculations are shown in the following table:—

Crank angle θ .	Position of piston. Fraction of stroke $= \frac{x}{2r}$.	Values of $(\cos \theta + \frac{1}{n} \cos 2\theta)$.
0	0	1.250
30	0.083	0.991
60	0.296	0.375
76	0.438	0.000
90	0.562	-0.250
120	0.796	-0.625
150	0.980	-0.741
180	1.000	-0.750

The dotted lines in Fig. 205 show the acceleration curves on a stroke base for an infinitely long connecting rod, *i.e.* when $\frac{d^2x}{dt^2} = \omega^2 r \cos \theta$.

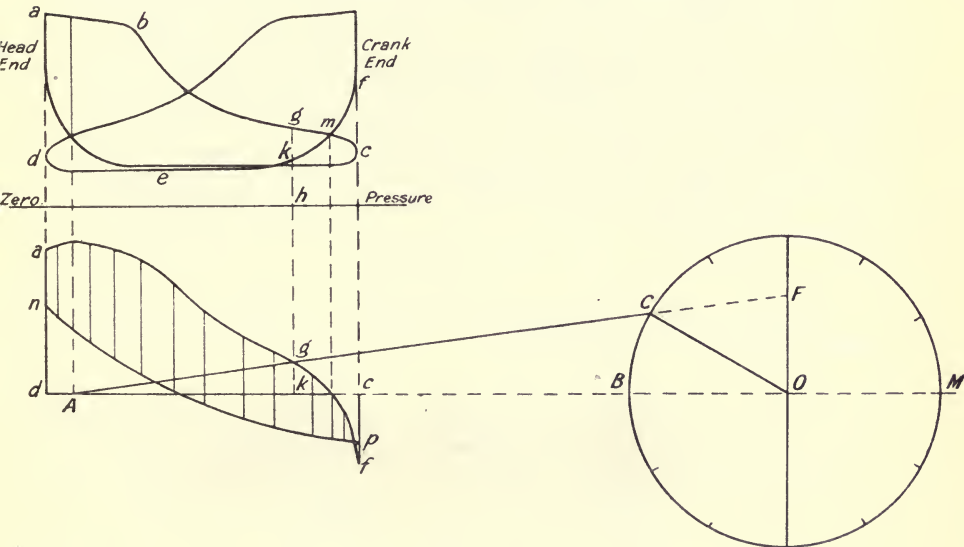

FIG. 206.

These curves will also represent the inertia forces to another scale since

$$\text{Accelerating force} = \frac{W}{g} \cdot \frac{d^2x}{dt^2}$$

where $W =$ weight of reciprocating parts.

238. Method of drawing the Twisting Moment Diagram.—

We will take the case of a horizontal single-cylinder double-acting steam engine. The work may be conveniently carried out as follows: The first step is to draw from an indicator diagram the *piston effort* diagram, which consists of a curve of P (Art. 236) on a stroke base. Let the indicator diagram be as shown in the upper part of Fig. 206.

Consider the instroke of the piston, *i.e.* the working stroke from the head end of the cylinder during which the piston is moving *towards* the crank-shaft. The curve *abc* gives the steam pressure on the head end piston at the various points of the stroke, and the curve *def* gives the pressure on the crank end of the piston during the same stroke. The effective driving pressure on the piston will evidently be the difference of the pressures on the two sides of the piston, *i.e.* at any point such as *g* the effective pressure will be

$$gh - kh = gk$$

At the point *m* the effective pressure will be zero, and from *m* onwards to the end of the stroke it will be *negative*. A separate curve of effective pressure may be plotted vertically below the indicator diagram as shown, on which ordinates *above* the base line *dc* represent to scale the *positive* effective force on the piston and ordinates *below* the negative force.

Next add the inertia line *np* as described in Art. 237. Produce the base line *dc*, and set out the crank-pin circle to the same scale, *i.e.* make *cM = dB =* length of connecting rod, and *BM = dc =* stroke of piston.

Divide the crank-pin circle into, say, 12 equal angles, *i.e.* every 30° ; then for any position of the crank such as *OC* put on the centre line *AC* of the connecting rod, and produce it to cut the perpendicular to the line of stroke through *O* in point *F*. Erect a perpendicular from *A*; the length of this ordinate intercepted by the curves *agf* and *np* will represent to scale the effective driving force *P* (pounds) on the piston; scale off the length *OF* in feet. Then, as proved in Art. 236, the twisting moment for this position of the crank is

$$P \times OF \text{ pound feet}$$

Draw up a table showing the value of *P* and of *OF* for the different crank angles taken as shown below.

Crank angle. θ° .	P (pounds).	OF (feet).
0		
30		
60		
90		
120		
150		
180		

Repeat the process for the outstroke, *i.e.* whilst the crank angle varies from 180° to 360° , drawing the piston effort curve for this stroke in exactly the same way as described above for the instroke. The twisting moment may then be plotted either on a crank-pin circle base as shown in Fig. 207, or as a polar diagram as shown in Fig. 208.

The common approximation used in practice when drawing the inertia line *np* (Fig. 206) is to treat a portion of the weight of the connecting rod as reciprocating, and to take the total weight of reciprocating parts as the

sum of the weights of the piston, piston rod, crosshead, crosshead pin, and that part of the connecting rod between the crosshead pin and the centre of gravity of the rod. This will usually give results quite accurate enough for all practical purposes (see Art. 241). The effect of frictional resistance is also neglected in practice, the effective effort P on the piston being

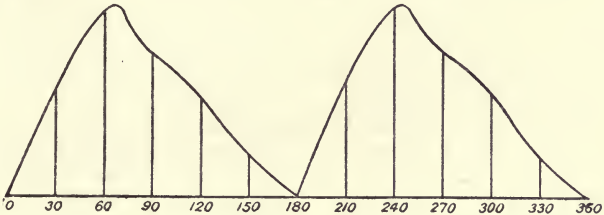

FIG. 207.

merely taken as the difference between the steam pressures on the two sides of the piston multiplied by the area of the piston *minus* the inertia force $\frac{W}{g} \cdot \frac{d^2x}{dt^2}$ in the case of a horizontal engine.

In the case of a vertical engine it will be evident that on the *downward*

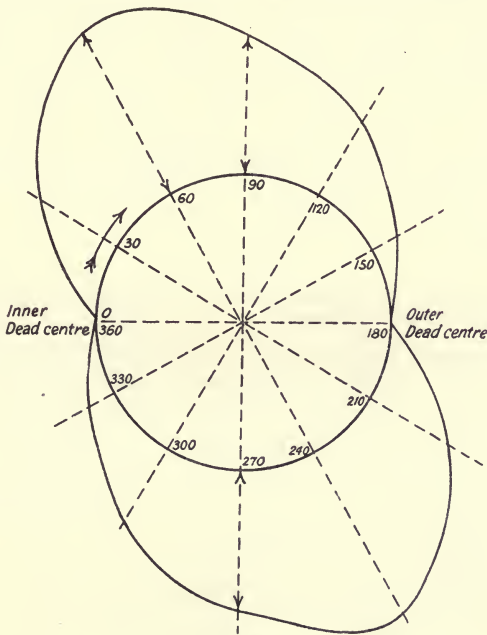

FIG. 208.

stroke the weight of the reciprocating parts must be *added* to the effort P found as above and *subtracted* from the effort P for the *upward* stroke.

When the engine has more than one cylinder, each driving its own

crank, the twisting moment diagram should be drawn for each cylinder, and the sum of them taken. Fig. 209 shows the diagram for a three-cylinder engine with cranks at 120° .

In the case of an internal combustion engine exactly the same method is followed. It will be evident that in the single-cylinder single-acting four-stroke cycle engine the twisting moment will be very irregular, since there is only one working stroke every four strokes or every two revolutions. If the twisting moment diagram be required in such a case with a reasonable degree of accuracy, the inertia line and piston effort curve must be drawn for *each* of the four strokes.

∠ 239. **Inertia of the Connecting Rod.**—As already mentioned above, the usual method adopted in practice is to divide the connecting rod into two masses, which are then assumed concentrated at the crank pin and the crosshead pin respectively. When great accuracy is desirable, however, particularly in the case of high-speed engines, this simple

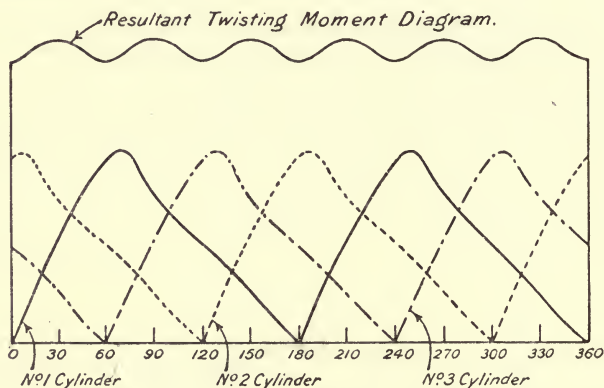

FIG. 209.

approximation cannot be used, and an exact method (one of which is developed below) must be followed.

Let s = horizontal distance of the mass centre of the connecting rod from its position at the end of the stroke at any instant.

x = distance of the piston from the end of its stroke.

y = perpendicular distance of the mass centre of the connecting rod from the line of stroke (see Fig. 210).

θ = crank angle measured from the inner dead centre.

ϕ = inclination of the connecting rod to the line of stroke.

w = weight of the connecting rod.

ω = angular velocity of the connecting rod.

The first step is to obtain expressions for

∠ (a) Angular acceleration of the connecting rod.

(b) Acceleration of the mass centre of the connecting rod $\left(\frac{d^2s}{dt^2} \text{ and } \frac{d^2y}{dt^2}\right)$.

∠ (c) Acceleration of the piston $\frac{d^2x}{dt^2}$ (see Art. 237).

(a) Angular Acceleration of the Connecting Rod.

Now

$$l \sin \phi = r \sin \theta$$

$$\therefore \sin \phi = \frac{r}{l} \sin \theta$$

$$\sin \phi = \frac{1}{n} \sin \theta \dots \dots \dots (1)$$

Differentiating (1), we have

$$\begin{aligned} \cos \phi \cdot \frac{d\phi}{dt} &= \frac{1}{n} \cos \theta \cdot \frac{d\theta}{dt} \\ &= \frac{\omega}{n} \cos \theta \end{aligned}$$

$$\therefore \frac{d\phi}{dt} = \frac{\omega \cos \theta}{n \cos \phi} = \frac{\omega \cos \theta}{\sqrt{n^2 - \sin^2 \theta}} \dots \dots (2)$$

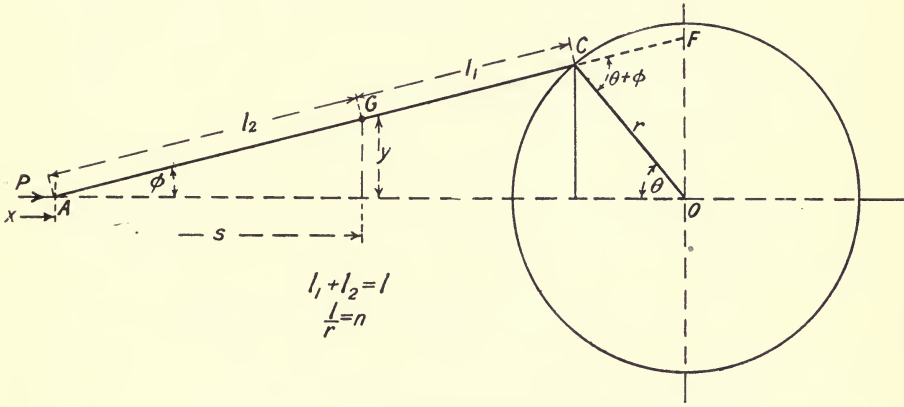

FIG. 210.

Differentiating (2), we have

$$\frac{d^2\phi}{dt^2} = - \frac{\omega^2(n^2 - 1) \sin \theta}{(n^2 - \sin^2 \theta)^{\frac{3}{2}}} \dots \dots \dots (3)$$

(b) Acceleration of the Mass Centre of the Connecting Rod.—From Fig. 210

$$y = l_2 \sin \phi \dots \dots \dots (4)$$

$$= l_2 \frac{r}{l} \sin \theta \dots \dots \dots (5)$$

$$\therefore \frac{dy}{dt} = \frac{d\theta}{dt} \cdot \frac{dy}{d\theta} = \omega \cdot l_2 \frac{r}{l} \cos \theta \dots \dots \dots (6)$$

and

$$\frac{d^2y}{dt^2} = - l_2 \cdot \frac{r}{l} \cdot \omega^2 \sin \theta \dots \dots \dots (7)$$

Also, from Fig. 210

$$\begin{aligned} s &= x - l_2(1 - \cos \phi) \dots \dots \dots (8) \\ &= r(1 - \cos \theta) + l(1 - \cos \phi) - l_2(1 - \cos \phi) \\ &= r(1 - \cos \theta) + (l - l_2)(1 - \cos \phi) \\ &= r(1 - \cos \theta) + l_1(1 - \cos \phi) \end{aligned}$$

since

$$\begin{aligned} l &= l_1 + l_2 \\ r &= r\left(\frac{l_1}{l} + \frac{l_2}{l}\right) \end{aligned}$$

$$\begin{aligned} \therefore s &= r \cdot \frac{l_1}{l}(1 - \cos \theta) + r \cdot \frac{l_2}{l}(1 - \cos \theta) + l_1 \cdot \frac{l_2}{l}(1 - \cos \phi) \\ &= \frac{l_1}{l}\{r(1 - \cos \theta) + l(1 - \cos \phi)\} + \frac{l_2}{l} \cdot r(1 - \cos \theta) \\ &= \frac{l_1}{l} \cdot x + \frac{l_2}{l} \cdot r(1 - \cos \theta) \dots \dots \dots (9) \end{aligned}$$

or

$$s = \frac{l_1}{l}(A's \text{ horizontal displacement}) + \frac{l_2}{l}(C's \text{ horizontal displacement}) \dots \dots \dots (9A)$$

which is a well-known general principle.

Differentiating (8), we have

$$\frac{ds}{dt} = \frac{dx}{dt} - l_2 \sin \phi \cdot \frac{d\phi}{dt} \dots \dots \dots (10)$$

Substituting for $\frac{dx}{dt}$ from (5), Art. 237, and for $\sin \phi$ and $\frac{d\phi}{dt}$ from (2) above, we have

$$\frac{ds}{dt} = \omega r \left(\sin \theta + \frac{\sin \theta \cos \theta}{\sqrt{n^2 - \sin^2 \theta}} \right) - \frac{l_2 \cdot \omega \cdot \sin \theta \cos \theta}{n \sqrt{n^2 - \sin^2 \theta}} \dots (11)$$

Also, by differentiating (9), we have the general principle

$$\begin{aligned} \frac{ds}{dt} &= \frac{l_1}{l} \cdot \frac{dx}{dt} + \frac{l_2}{l} \cdot \omega r \sin \theta \dots \dots \dots (12) \\ &= \frac{l_1}{l}(A's \text{ velocity}) + \frac{l_2}{l}(C's \text{ horizontal velocity}) \dots (12A) \end{aligned}$$

Differentiating (10), we have

$$\frac{d^2s}{dt^2} = \frac{d^2x}{dt^2} - l_2 \left\{ \sin \phi \cdot \frac{d^2\phi}{dt^2} + \cos \phi \cdot \left(\frac{d\phi}{dt}\right)^2 \right\} \dots (13)$$

Also by differentiating (12), we have the general principle

$$\begin{aligned} \frac{d^2s}{dt^2} &= \frac{l_1}{l} \cdot \frac{d^2x}{dt^2} + \frac{l_2}{l} \omega^2 r \cos \theta \dots \dots \dots (14) \\ &= \frac{l_1}{l}(A's \text{ acceleration}) + \frac{l_2}{l}(C's \text{ horizontal acceleration}) \dots (14A) \end{aligned}$$

The resultant acceleration of the mass centre of the rod will be

$$\sqrt{\left(\frac{d^2s}{dt^2}\right)^2 + \left(\frac{d^2y}{dt^2}\right)^2}$$

Approximate effect of the inertia of the connecting rod on the Twisting Moment.—In this approximation the angular motion of the rod is neglected. Dividing the rod into two parts of weight, w_2 at A and w_1 at C, such that

$$w_2 = \frac{l_1}{l} \cdot w \text{ and } w_1 = \frac{l_2}{l} \cdot w$$

we have Thrust along the rod $Q = \left(P - \frac{w_2}{g} \cdot \frac{d^2x}{dt^2} \right) \sec \phi \dots (15)$

where $P =$ effective steam pressure on piston — frictional resistance — $\frac{W}{g} \cdot \frac{d^2x}{dt^2}$, in which $W =$ weight of piston, piston rod, crosshead, and crosshead pin.

Resolving (15) perpendicular to the crank and multiplying by r , we have

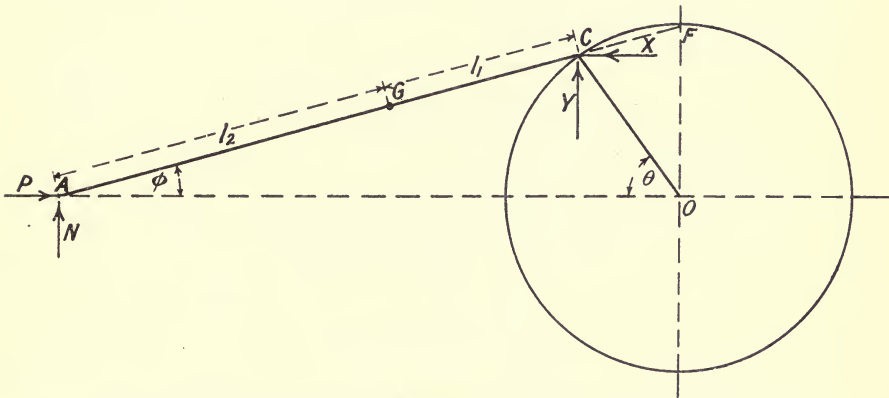

FIG. 211.

$$\left. \begin{array}{l} \text{Twisting moment in} \\ \text{direction of rotation} \end{array} \right\} = \left(P - \frac{w_2}{g} \cdot \frac{d^2x}{dt^2} \right) \sec \phi \times r \sin (\theta + \phi) \quad (16)$$

$$= \left(P - \frac{w_2}{g} \cdot \frac{d^2x}{dt^2} \right) \times OF \dots (16A)$$

The effect on the twisting moment of the inertia of the rod alone is found approximately by putting $P = 0$ in (16), which gives

$$\left. \begin{array}{l} \text{Twisting moment in} \\ \text{direction of rotation} \\ \text{due to rod alone} \end{array} \right\} = - \frac{w_2}{g} \cdot \frac{d^2x}{dt^2} \sec \phi \times r \sin (\theta + \phi) \dots (17)$$

$$= - \frac{w_2}{g} \cdot \frac{d^2x}{dt^2} \times OF \dots (17A)$$

Exact effect of the inertia of the connecting rod on the Twisting Moment.—Referring to Fig. 211

Let X = horizontal force exerted by the *crank on the rod*.

Y = vertical force exerted by the *crank on the rod*.

Then, neglecting friction, we have the equations of motion

$$\frac{w}{g} \cdot \frac{d^2s}{dt^2} = P - X \dots \dots \dots (18)$$

$$\frac{w}{g} \cdot \frac{d^2y}{dt^2} = N + Y \dots \dots \dots (19)$$

$$I_A \cdot \frac{d^2\phi}{dt^2} = Yl \cos \phi + Xl \sin \phi \dots \dots \dots (20)$$

where I_A = moment of inertia of the rod about the crosshead pin A

$$= I_G + \frac{w}{g} l_2^2 = \frac{w}{g} (k^2 + l_2^2)$$

in which k = radius of gyration of the rod about G.

From (18) and (20) we have

$$Y = \frac{I_A \cdot \frac{d^2\theta}{dt^2} - l \sin \phi \left(P - \frac{w}{g} \cdot \frac{d^2s}{dt^2} \right)}{l \cos \phi} \dots \dots \dots (21)$$

and the effect of the rod alone when $P = 0$

$$Y = \frac{I_A \cdot \frac{d^2\phi}{dt^2} - l \sin \phi \left(0 - \frac{w}{g} \cdot \frac{d^2s}{dt^2} \right)}{l \cos \phi}$$

$$= \frac{I_A \cdot \frac{d^2\phi}{dt^2}}{l \cos \phi} + \frac{w}{g} \cdot \frac{d^2s}{dt^2} \cdot \tan \phi \dots \dots \dots (22)$$

Now the twisting moment exerted *on* the crank pin arises from the *reactions* of X and Y, *i.e.* from X and Y reversed in direction, hence the twisting moment is

$$Xr \sin \theta - Yr \cos \theta$$

Substituting for X and Y from (18) and (21), we have

$$\text{Twisting moment} = \left(P - \frac{w}{g} \cdot \frac{d^2s}{dt^2} \right) r \sin \theta - \left\{ \frac{I_A}{l} \cdot \frac{d^2\phi}{dt^2} \cdot \sec \phi \right. \\ \left. + \left(\frac{w}{g} \cdot \frac{d^2s}{dt^2} - P \right) \tan \phi \right\} r \cos \theta \dots \dots (23)$$

For the effect of the rod only $P = 0$, and the twisting moment in the direction of rotation is from (23)

$$- \frac{w}{g} \cdot \frac{d^2s}{dt^2} r (\sin \theta + \tan \phi \cos \theta) - \frac{I_A r}{l} \cdot \frac{d^2\phi}{dt^2} \sec \phi \cos \theta \dots \dots (24)$$

or
$$- \frac{w}{g} \cdot r \left\{ \frac{d^2s}{dt^2} (\sin \theta + \tan \phi \cos \theta) + \frac{k^2 + l_2^2}{l} \cdot \frac{d^2\phi}{dt^2} \cdot \sec \phi \cos \theta \right\} \dots (25)$$

240. Comparison of the Exact Effect and the Approximate Effect of the Inertia of the Connecting Rod on the Twisting Moment.—The centre of gravity of the rod is at G (Fig. 211) in both cases, the only quantity which is different in the two cases being I_A , the moment of inertia of the connecting rod about the crosshead pin centre.

For the approximate effect $I_A = \frac{w_1}{g} l^2$, and the twisting moment due to the effect of the rod alone, taking account of its angular motion, is therefore from (24), Art. 239,

$$-\frac{w}{g} \cdot \frac{d^2s}{dt^2} \cdot r(\sin \theta + \tan \phi \cos \theta) - \frac{w_1}{g} \cdot l^2 \cdot \frac{r}{l} \cdot \frac{d^2\phi}{dt^2} \sec \phi \cos \theta \quad \dots (1)$$

The exact twisting moment due to the rod alone is given by (24), Art. 239, viz. :—

$$-\frac{w}{g} \cdot \frac{d^2s}{dt^2} \cdot r(\sin \theta + \tan \phi \cos \theta) - \frac{I_A \cdot r}{l} \cdot \frac{d^2\phi}{dt^2} \sec \phi \cos \theta \quad \dots (2)$$

The exact effect is therefore greater than the approximate effect by the amount

$$\begin{aligned} & \dots (2) - (1) \\ &= -\frac{I_A r}{l} \cdot \frac{d^2\phi}{dt^2} \sec \phi \cos \theta - \left(-\frac{w_1}{g} l^2 \cdot \frac{r}{l} \cdot \frac{d^2\phi}{dt^2} \sec \phi \cos \theta \right) \\ &= -\frac{w}{g} \left(\frac{k^2 + l_2^2}{l} \right) \cdot \frac{d^2\phi}{dt^2} \cdot r \sec \phi \cos \theta + \frac{w}{g} \cdot l_2 \cdot \frac{d^2\phi}{dt^2} \cdot r \sec \phi \cos \theta \\ &= -\frac{w}{g} \cdot \frac{d^2\phi}{dt^2} \sec \phi \left(\frac{k^2 + l_2^2}{l} - \frac{l_2}{l} \right) r \cos \theta \\ &= -\frac{w}{g} \cdot \frac{d^2\phi}{dt^2} \cdot r \sec \phi \cos \theta \left(\frac{k^2 - l_1 l_2}{l} \right) \dots \dots \dots (3) \end{aligned}$$

The approximation will give the twisting moment accurately when $k^2 = l_1 l_2$, in which case (3) is equal to zero. In almost all connecting rods k^2 is less than $l_1 l_2$, and the excess twisting moment given by (3) is positive when $\cos \theta$ is negative, i.e. when θ is between 90° and 270° , and negative when $\cos \theta$ is positive, i.e. when θ is between 0° and 90° and between 270° and 360° .

The radius of gyration (k) of the rod may be conveniently found as follows :—First find the position of the centre of gravity of the rod, l_2 , from the crosshead end; then swing the rod as a pendulum about knife edges at the centre of the small end, and find experimentally the length (d) of a simple pendulum which has the same period. The point on the rod distant d from the centre of the small end is known as the centre of percussion, its distance from the centre of gravity of the rod being $d - l_2$. Then it may easily be shown that

$$k^2 = l_2 \times (d - l_2) \dots \dots \dots (4)$$

241. Kinetic Energy of the Connecting Rod.—The kinetic energy of the rod when in any position is made up of two parts, namely—

$$(1) \text{ The kinetic energy of translation} = \frac{wv^2}{2g}$$

$$(2) \text{ The kinetic energy of rotation} = \frac{1}{2}I\left(\frac{d\phi}{dt}\right)^2$$

The resultant velocity v of the mass centre of the rod is

$$v = \sqrt{\left(\frac{ds}{dt}\right)^2 + \left(\frac{dy}{dt}\right)^2}$$

Hence (1) above is

$$\frac{w}{2g}\left\{\left(\frac{ds}{dt}\right)^2 + \left(\frac{dy}{dt}\right)^2\right\}$$

The kinetic energy due to rotation of the rod about its centre of gravity is

$$\frac{1}{2}I\left(\frac{d\phi}{dt}\right)^2$$

where I = moment of inertia of the rod about an axis passing through its centre of gravity.

Hence the total kinetic energy of the rod is the sum of (1) and (2), viz. :—

$$E = \frac{w}{2g}\left\{\left(\frac{ds}{dt}\right)^2 + \left(\frac{dy}{dt}\right)^2\right\} + \frac{1}{2}I\left(\frac{d\phi}{dt}\right)^2 \quad \dots \quad (1)$$

The twisting moment exerted on the crankshaft by the rod may also be found from its kinetic energy, since for a small angle $\delta\theta$ over which the twisting moment exerted by the rod is T , we have

$$\begin{aligned} -\delta E &= T\delta\theta \\ \therefore T &= -\frac{\delta E}{\delta\theta} \quad \dots \quad (2) \end{aligned}$$

Differentiating (1) with respect to θ we have

$$\begin{aligned} T &= -\frac{dE}{d\theta} = -\frac{dE}{dt} \cdot \frac{dt}{d\theta} \\ T &= -\frac{1}{\omega} \cdot \frac{dE}{dt} \\ &= -\frac{1}{\omega} \cdot \frac{w}{2g} \left\{ \frac{d}{dt} \left(\frac{ds}{dt} \right)^2 + \frac{d}{dt} \left(\frac{dy}{dt} \right)^2 + k^2 \cdot \frac{d}{dt} \left(\frac{d\phi}{dt} \right)^2 \right\} \\ &= -\frac{w}{\omega g} \left\{ \frac{d^2s}{dt^2} \cdot \frac{ds}{dt} + \frac{d^2y}{dt^2} \cdot \frac{dy}{dt} + k^2 \cdot \frac{d^2\phi}{dt^2} \cdot \frac{d\phi}{dt} \right\} \quad \dots \quad (3) \end{aligned}$$

where k is the radius of gyration of the rod about its centre of mass.

✓ 242. **Graphical Method for Finding the Twisting Moment exerted by the Connecting Rod.**—The force required to give the mass centre of the rod its acceleration may be first found. It will be

$$\begin{aligned} &\frac{w}{g} \times \text{acceleration of the mass centre} \\ &= \frac{w}{g} \cdot \sqrt{\left(\frac{d^2s}{dt^2}\right)^2 + \left(\frac{d^2y}{dt^2}\right)^2} \end{aligned}$$

The construction for finding $\sqrt{\left(\frac{d^2s}{dt^2}\right)^2 + \left(\frac{d^2y}{dt^2}\right)^2}$ is shown in Fig. 212.

Set out the centre lines of the rod and crank. Find the acceleration BO of the piston A by Klein's construction (Fig. 204). Join CB and draw GD parallel to AO to meet it in point D; join DO. Then DO represents the

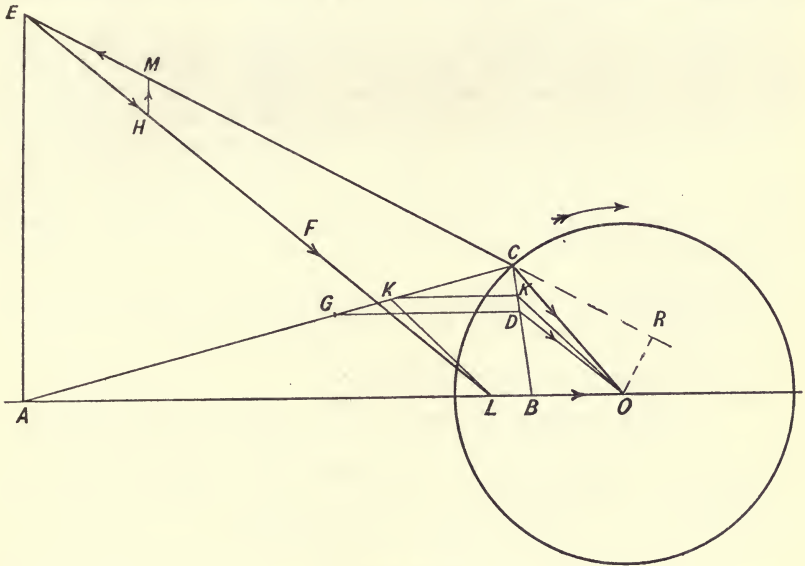

FIG. 212.

acceleration of the mass centre of the rod in magnitude and direction to the same scale as $CO = \omega^2 r$, the centripetal acceleration of the crank pin,

or acceleration of mass centre $= \omega^2 DO$

and accelerating force on rod $F = \frac{w}{g} \omega^2 DO$

Since the rod has an angular acceleration the force F will not pass through the centre of gravity G of the rod, but will give the couple about G , which is required to produce the angular acceleration of the rod. Find the point K such that AK is equal to the length of a simple pendulum which has the same period as the connecting rod when it oscillates about an axis passing through A (K is called the centre of percussion). Draw Kk parallel to GD and join kO ; then kO gives the acceleration of point K . From K draw KL parallel to kO to meet the line of stroke AO in point L . Then L is a point on the line of action of the force F , which must therefore pass through L and be parallel to DO .

To find the turning moment exerted on the crankshaft, draw AE perpendicular to AO to meet the line of action of the force F in point E .

Set off EH to represent the force $F = \frac{w}{g} \omega^2 DO$ to any convenient scale,

join EC and from H draw HM parallel to AE. Then ME is the equivalent force acting on the crank pin, and the turning moment on the crankshaft is

$$ME \times \text{perpendicular distance OR}$$

in a direction opposite to the direction of rotation. As shown in Fig. 212 θ is between 0° and 90° , hence the twisting moment exerted on the crankshaft by the rod is negative (cf. end of Art. 242).¹

EXAMPLE 1.—The connecting rod of an engine weighs 100 pounds and is 4 feet long, the crank being 1 foot in length. The centre of gravity of the rod is 2.5 feet from the crosshead end. The diameter of the cylinder is 15 inches, the engine runs at 240 revolutions per minute. If the weight of the reciprocating parts other than the connecting rod is 300 pounds, find the twisting moment when the crank angle is 30° from the inner dead centre, the steam pressure on the head end of the piston being 80 pounds per square inch, and on the crank end 20 pounds per square inch. Assume the rod to be equivalent to two masses, at the crank pin and crosshead pin respectively.

Angular velocity of crankshaft $\omega = \frac{240}{60} \times 2\pi = 8\pi$ radians per second.

Acceleration of piston when $\theta = 30^\circ$ is by (8), Art. 237

$$\begin{aligned} \frac{d^2x}{dt^2} &= (8\pi)^2 \times 1 (\cos 30^\circ + \frac{1}{4} \cos 60^\circ) \\ &= 64\pi^2 (0.8660 + 0.1250) = 625 \text{ feet per second per second.} \end{aligned}$$

Portion of connecting rod to be assumed concentrated at the crosshead pin

$$= \frac{2.5}{4} \times 100 = 62.5 \text{ pounds}$$

\therefore total weight of reciprocating parts $W = 300 + 62.5 = 362.5$ pounds

$$\text{Accelerating force} = \frac{362.5}{32.2} \times 625 = 7040 \text{ pounds}$$

$$\begin{aligned} \text{Effective force on piston} \left. \begin{array}{l} \text{due to steam pressure} \end{array} \right\} &= (80 - 20) \times 0.7854 \times (15)^2 \\ &= 60 \times 176.7 \\ &= 10,600 \text{ pounds} \end{aligned}$$

$$\therefore P = 10,600 - 7040 = 3560 \text{ pounds}$$

and twisting moment by ((2), Art. 236) is

$$T = Pr \sec \phi \sin (\theta + \phi)$$

$$\text{Now } \sin \phi = \frac{r}{n} \sin \theta \text{ ((2), Art. 237)}$$

$$\begin{aligned} \therefore \sec \phi &= \frac{n}{\sqrt{n^2 - \sin^2 \theta}} = \frac{4}{\sqrt{16 - (0.5)^2}} \\ &= \frac{4}{3.968} = 1.0080 \end{aligned}$$

$$\therefore \phi = \sec^{-1} 1.0080 = 7.2^\circ$$

¹ For other graphical methods, see Dalby's "Balancing of Engines." Edward Arnold.

$$\begin{aligned} \text{and } \sin(\theta + \phi) &= \sin 37.2 = 0.6046 \\ \therefore T &= 3560 \times 1 \times 1.0080 \times 0.6046 \\ &= 2170 \text{ pound-feet} \end{aligned}$$

EXAMPLE 2.—The connecting rod of an engine weighs 1500 pounds, and is 6 feet long, and the crank is 1 foot 9 inches long. The centre of gravity of the rod is 4 feet from the crosshead end. The engine makes 100 revolutions per minute, and the connecting rod when oscillating about its small end swings in unison with a simple pendulum 5 feet long. Find the twisting moment exerted by the rod in the direction of rotation and the kinetic energy of the rod when the crank angle is 45° from the inner dead centre

$$\omega = \frac{100}{60} \times 2\pi = \frac{10\pi}{3} \text{ radians per second}$$

First find the radius of gyration of the rod about its centre of gravity.

$$\begin{aligned} k^2 &= 4 \times (5 - 4) = 4 \\ \therefore k &= 2 \text{ feet} \end{aligned}$$

Using the notation of Art. 239, we have

since

$$\begin{aligned} n &= \frac{6}{1.75} = \frac{24}{7} = 3.43 \\ \frac{d^2x}{dt^2} &= \frac{100\pi^2}{9} \times 1.75 \left(0.707 + \frac{7}{24} \times 0 \right) \\ &= \frac{987 \times 1.75}{9} \times 0.707 = 135 \text{ ft. per sec. per sec.} \end{aligned}$$

$$\begin{aligned} \frac{dx}{dt} &= \omega r \left(\sin \theta + \frac{\sin 2\theta}{2n} \right) \\ &= \frac{10\pi}{3} \times 1.75 \left(0.707 + \frac{7}{48} \right) \\ &= \frac{31.416 \times 1.75}{3} \times 0.853 = 15.6 \text{ ft. per sec.} \end{aligned}$$

$$\begin{aligned} \frac{ds}{dt} &= \frac{l_1}{l} \cdot \frac{dx}{dt} + \frac{l_2}{l} \cdot \omega r \sin \theta \quad ((12), \text{ Art. 239}) \\ &= \frac{2}{6} \times 15.6 + \frac{4}{6} \times \frac{10\pi}{3} \times 1.75 \times 0.707 \\ &= 5.2 + 8.63 \\ &= 13.83 \text{ ft. per second} \end{aligned}$$

$$\begin{aligned} \frac{dy}{dt} &= \omega \cdot l_2 \cdot \frac{r}{l} \cos \theta \quad ((6), \text{ Art. 239}) \\ &= \frac{10\pi}{3} \times 4 \times \frac{1.75}{6} \times 0.707 \\ &= 8.63 \text{ ft. per second} \end{aligned}$$

$$\frac{d^2s}{dt^2} = \frac{l_1}{l} \cdot \frac{d^2x}{dt^2} + \frac{l_2}{l} \cdot \omega^2 r \cos \theta \quad ((14), \text{ Art. 239})$$

$$\begin{aligned}
&= \frac{2}{6} \times 135 + \frac{4}{6} \times \frac{100\pi^2}{9} \times 1.75 \times 0.707 \\
&= 45 + 90 \\
&= 135 \text{ ft. per sec. per sec.} \\
\frac{d\phi}{dt} &= \frac{\omega \cos \theta}{\sqrt{n^2 - \sin^2 \theta}} \quad ((2), \text{ Art } 239) \\
&= \frac{10\pi}{3} \cdot \frac{0.707}{\sqrt{(3.43)^2 + (0.707)^2}} \\
&= \frac{31.416 \times 0.707}{3 \times 3.36} = 2.20 \text{ radians per second} \\
\frac{d^2\phi}{dt^2} &= \frac{-\omega^2(n^2 - 1) \sin \theta}{(n^2 - \sin^2 \theta)^{\frac{3}{2}}} \quad ((3), \text{ Art. } 239) \\
&= -\frac{100\pi^2}{9} \times \frac{\{(3.43)^2 - 1\} \cdot 0.707}{\{(3.43)^2 - (0.707)^2\}^{\frac{3}{2}}} \\
&= -\frac{987}{9} \cdot \frac{1.075 \times 0.707}{38} \\
&= -22 \text{ radians per sec. per sec.}
\end{aligned}$$

The twisting moment exerted by the rod in the direction of rotation is

$$T = -\frac{w}{g} r \left\{ \frac{d^2s}{dt^2} (\sin \theta + \tan \phi \cos \theta) + \frac{k^2 + l^2}{l} \cdot \frac{d^2\phi}{dt^2} \sec \phi \cos \theta \right\} \quad ((25), \text{ Art. } 239)$$

$$\text{Now } \sin \phi = \frac{l}{n} \sin \theta, \quad \cos \phi = \frac{l}{n} \sqrt{n^2 - \sin^2 \theta}, \quad \tan \phi = \frac{\sin \theta}{\sqrt{n^2 - \sin^2 \theta}}$$

$$\text{i.e. } \sec \phi = \frac{3.43}{\sqrt{(3.43)^2 - (0.707)^2}} = \frac{3.43}{3.36} \text{ and } \tan \phi = \frac{0.707}{3.36}$$

Substituting in the expression for T we have:—

$$\begin{aligned}
\therefore T &= -\frac{1500}{32.2} \times 1.75 \left\{ 135 \left(0.707 + \frac{0.707}{3.36} \cdot \frac{3.36}{3.43} \right) \right. \\
&\quad \left. + \frac{4 + 16}{6} (-22) \cdot \frac{3.43}{3.36} \cdot 0.707 \right\} \\
&= -\frac{1500 \times 1.75}{3.22} \{ 135 \times 0.913 - 52.9 \} \\
T &= -\frac{1500 \times 1.75}{32.2} \times 70.6 \\
&= -5750 \text{ pound-feet}
\end{aligned}$$

The reader should check this figure graphically.

The kinetic energy of the rod is

$$E = \frac{w}{2g} \left\{ \left(\frac{ds}{dt} \right)^2 + \left(\frac{dy}{dt} \right)^2 \right\} + \frac{1}{2} \cdot \left(\frac{d\phi}{dt} \right)^2 \quad ((1), \text{ Art. } 241)$$

$$\begin{aligned}
 &= \frac{1500}{64 \cdot 4} \{ (13 \cdot 83)^2 + (8 \cdot 63)^2 \} + \frac{1}{2} \cdot \frac{1500}{32 \cdot 2} \times 4 \times (2 \cdot 2)^2 \\
 &= \frac{1500}{64 \cdot 4} \times 265 + \frac{6000}{64 \cdot 4} \times 4 \cdot 84 \\
 &= 6170 + 450 \\
 &= 6620 \text{ foot-pounds}
 \end{aligned}$$

EXAMPLE 3.—In an inverted direct-acting engine the stroke is 2 feet, length of connecting rod 4 feet, cylinder 14 inches diameter, weight of reciprocating parts 300 pounds, and the speed 180 revolutions per minute. On the down stroke, at the commencement of the stroke the difference of pressures on the two sides of the piston was 40 pounds per square inch (acting downwards); at the end of the stroke the difference of pressure was 10 pounds per square inch (acting upwards). Find the effective pressure transmitted to the crank pin in these positions. If the steam pressures remained unaltered, at what speed would the engine have to run in order to make the effective pressure at the end of the stroke zero, and what would then be the effective pressure at the commencement of the stroke?

At the commencement of the stroke the accelerating force is

$$\frac{W}{g} \omega^2 r \left(1 + \frac{r}{n} \right) \quad ((10), \text{ Art. } 237)$$

In this example $r = 1$ foot, $\omega = 2\pi \times \frac{180}{60} = 6\pi$, $n = 4$

$$\begin{aligned}
 \therefore \text{accelerating force} &= \frac{300}{32 \cdot 2} \times 36\pi^2 \left(1 + \frac{1}{4} \right) \\
 &= 4140 \text{ pounds}
 \end{aligned}$$

$$\text{area of piston} = \frac{\pi}{4} \times (14)^2 = 154 \text{ square inches}$$

$$\therefore \text{accelerating force per sq. in. of piston area} = \frac{4140}{154} = 26 \cdot 8 \text{ lbs. per sq. in.}$$

$$\text{weight of reciprocating parts per sq. in. of piston area} = \frac{300}{154} = 1 \cdot 95 \text{ lbs. per sq. in.}$$

$$\therefore \text{effective downward pressure transmitted to crank pin} = 40 + 1 \cdot 95 - 26 \cdot 8 = 15 \cdot 15 \text{ lbs. per sq. in.}$$

$$\text{or total force} = 15 \cdot 15 \times 154 = 2333 \text{ pounds.}$$

At the end of the stroke the accelerating force is

$$\frac{W}{g} \omega^2 r \left(1 - \frac{r}{n} \right) \quad ((11), \text{ Art. } 237)$$

$$= \frac{300}{32 \cdot 2} \times 36\pi^2 \left(1 - \frac{1}{4} \right)$$

$$= 2480 \text{ pounds}$$

$$= \frac{2480}{154} = 16 \cdot 1 \text{ pounds per square inch of piston area}$$

$$\therefore \text{effective downward pressure exerted on crank pin} = 1 \cdot 95 - 10 + 16 \cdot 1 = 8 \cdot 05 \text{ lbs. per sq. in.}$$

$$\text{or total force} = 8 \cdot 05 \times 154 = 1240 \text{ pounds downwards.}$$

For the effective pressure at the end of the stroke to be zero, the accelerating force must be equal to $10 - 1.95 = 8.05$ pounds per square inch

or total inertia force $= 8.05 \times 154 = 1240$ pounds.

Hence if ω is the angular velocity required we have

$$\begin{aligned} \frac{300}{32.2} \times \omega^2 \left(1 - \frac{1}{4}\right) &= 1240 \\ \omega^2 &= \frac{1240 \times 32.2}{300 \times 0.75} = 177 \\ \omega &= \sqrt{177} = 13.3 \text{ radius per second} \\ &= \frac{13.3 \times 60}{2\pi} = 127 \text{ revolutions per minute.} \end{aligned}$$

At the commencement of the down stroke

$$\begin{aligned} \text{Accelerating force} &= \frac{300}{32.2} \times 177 \times \left(1 + \frac{1}{4}\right) \\ &= 2165 \text{ pounds} \\ &= \frac{2165}{154} = 13.4 \text{ pounds per square inch} \end{aligned}$$

$$\begin{aligned} \therefore \text{effective pressure} &= 1.95 + 4.0 = 13.4 \\ &= 28.55 \text{ pounds per square inch} \\ \text{or total force} &= 28.55 \times 154 = 4400 \text{ pounds} \end{aligned}$$

243. Function of the Flywheel—Cyclic Variation of Speed.—

Let Fig. 213 be the twisting moment diagram drawn as explained in Art. 238.

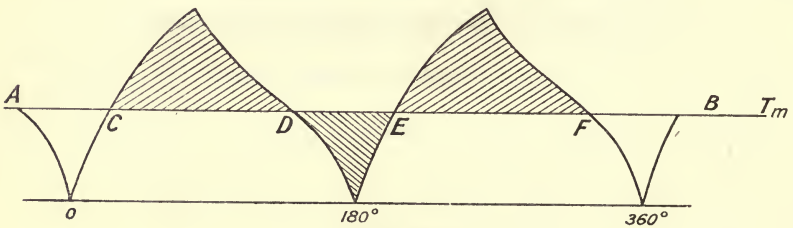

FIG. 213.

The area under this curve will represent to scale the work done on the piston, and should be compared with the work done as obtained from the indicator diagram. The resistance on the crankshaft may be assumed constant and be expressed as a resisting moment, being equal to the actual torque on the crankshaft *plus* the equivalent torque required to overcome engine friction.

Find the mean height of the twisting moment diagram by measuring its area (using, say, a planimeter), and dividing by the length, and draw the line AB to represent this mean twisting moment. The accuracy of the work may be checked by calculating the mean twisting moment from the I.H.P. as follows:—

Let T_m = mean twisting moment in pound-feet,
 n = mean speed of shaft in revolutions per minute.

Then
$$\text{I.H.P.} = \frac{T_m \times 2\pi n}{33,000}$$

and
$$T_m = \frac{\text{I.H.P.} \times 33,000}{2\pi n}$$

Then at points C, D, E, and F the equivalent twisting moment exerted on the shaft is equal to the resisting moment and the speed is constant. From C to D, and also from E to F, the shaded areas above CD and EF represent the excess work done on the piston over that taken of the crankshaft, and the engine will accelerate in speed from the minimum value at C or E to the maximum value at D or F. From D to E the work taken off the crankshaft is greater than that done on the shaft by the shaded area shown, and the speed will fall from the maximum value at D to the minimum value at E.

The function of the flywheel is to absorb the excess energy from, say, C to D with a pre-determined rise in speed, and to restore it again from D to E with the same fall in speed. The flywheel must therefore be designed to give a pre-determined cyclic variation in speed.

Let ω = mean speed in radians per second,
 ω_1 = maximum speed in radians per second,
 ω_2 = minimum " " " "

Then the excess energy to be stored by the flywheel is

$$e = \frac{1}{2}I (\omega_1^2 - \omega_2^2)$$

where I = moment of inertia of the wheel = $\frac{W}{g}k^2$

$$e = \frac{1}{2}I (\omega_1 + \omega_2)(\omega_1 - \omega_2)$$

Now
$$\omega = \frac{\omega_1 + \omega_2}{2}$$

$$\therefore e = I\omega (\omega_1 - \omega_2) \dots \dots \dots (1)$$

$$= I\omega^2 \frac{(\omega_1 - \omega_2)}{\omega} \dots \dots \dots (2)$$

Let E = kinetic energy of the wheel when running at the mean speed ω .

Then
$$E = \frac{1}{2}I\omega^2 \dots \dots \dots (3)$$

(3) in (2) gives

$$e = 2E \frac{\omega_1 - \omega_2}{\omega} \dots \dots \dots (4)$$

or if q denotes the percentage variation in speed permissible

$$q = \frac{\omega_1 - \omega_2}{\omega} \times 100$$

and
$$e = \frac{2Eq}{100} \dots \dots \dots (5)$$

or
$$E = \frac{e}{2q} \times 100 \dots \dots \dots (6)$$

Also from (2)
$$e = I\omega^2 \frac{q}{100} \dots \dots \dots (7)$$

EXAMPLE 1.—A gas engine working on the four-stroke cycle develops 15 I.H.P. at 250 revolutions per minute. Assuming one explosion every 2 revolutions, that the resistance is uniform and that the speed is not to vary more than 1 per cent. above or below the mean speed, calculate the weight of flywheel required if its radius of gyration is 2.5 feet. Take the fluctuation of energy as 0.75 of that developed during a working stroke. (L.U.)

Excess energy to be stored by the wheel = $0.75 \times \frac{15 \times 33,000}{125}$
 = 2970 foot-pounds

By (7)
$$e = I\omega^2 \cdot \frac{q}{100}$$

$$\therefore 2970 = \frac{W}{32.2} \times (2.5)^2 \cdot \left(\frac{250 \times 2\pi}{60}\right)^2 \cdot \frac{2}{100}$$

$$2970 = \frac{W \times 6.25}{32.2} \times \left(\frac{25 \times \pi}{30}\right)^2 \times \frac{2}{100}$$

from which
$$W = \frac{2970 \times 32.2 \times 900 \times 100}{6.25 \times 625\pi^2 \times 2} = 1110 \text{ pounds}$$

EXAMPLE 2.—A gas engine is provided with two flywheels each of weight 11.5 cwts., and radius of gyration 1.87 feet. There is 1 working stroke in 2 revolutions. The diameter of the cylinder is 7.5 inches, stroke 9 inches and mean speed 250 revolutions per minute. The mean pressure during the firing stroke is 88.7 pounds per square inch, during the compression stroke 15.1 pounds per square inch, during the exhaust stroke 4.4 pounds per square inch and during the suction stroke, atmospheric. If the resistance be constant, find the percentage variation of speed of the engine. (L.U.)

Work done on the piston during explosion stroke } = $88.7 \times (0.7854 \times 7.5^2) \times 0.75$
 = $88.7 \times 44.18 \times 0.75$
 = 2939 foot-pounds.

Work expended during compression and exhaust strokes } = $(15.1 + 4.4) \times 44.18 \times 0.75$
 = 646 foot-pounds

$$\therefore \text{net work done per cycle} = 2939 - 646 = 2293 \text{ ft.-lbs.}$$

Excess energy during working stroke to be absorbed by the flywheels } = $2939 - \frac{2293}{4} = 2366 \text{ ft.-lbs.}$

Moment of inertia of both flywheels together } = $\frac{23 \times 112}{32.2} \times (1.87)^2$
 = 280 pound-feet units.

$$\therefore I \cdot \omega^2 \cdot \left(\frac{\omega_1 - \omega_2}{\omega}\right) = 2366$$

$$\omega = \frac{250 \times 2\pi}{60} = \frac{25\pi}{3} \text{ radians per second}$$

$$\begin{aligned} \therefore \frac{\omega_1 - \omega_2}{\omega} &= \frac{2366}{280 \times \left(\frac{25\pi}{3}\right)^2} \\ &= \frac{2366 \times 9}{280 \times 625\pi^2} = 0.0123 \end{aligned}$$

\therefore percentage fluctuation of speed = 1.23 per cent., or 0.66 per cent. above or below mean speed.

EXAMPLES XIX

1. The connecting rod of a vertical engine weighs 210 pounds, and is 66 inches long, the stroke being 33 inches. The centre of gravity of the rod is 40 inches from the crosshead pin centre. The diameter of the cylinder is 20 inches, and the engine runs at 60 revolutions per minute. The combined weight of the piston, piston rod, crosshead, and crosshead pin is 600 pounds. Find the twisting moment when the crank is 60° from the inner dead centre and the piston is moving towards the crank shaft (*a*) neglecting the inertia of the reciprocating parts; (*b*) allowing for inertia, and assuming the rod to be equivalent to two masses at the crank pin and crosshead pin. For this position of the crank assume the steam pressure on the head end of the piston to be 60 pounds per square inch and on the crank end 10 pounds per square inch.

2. A horizontal engine, stroke 11 inches, connecting rod 2 feet 9 inches between centres, runs at 300 revolutions per minute. The mass of the rod is 105 pounds, distance of c.g. from crosshead centre 1.655 feet, and radius of gyration about the centre of gravity 1.075 feet. Find the kinetic energy of the rod when the piston is moving towards the crank shaft and the crank angle is 30° with the inner dead centre, and the effect upon the turning moment. Find also the approximate effect on the turning moment when the rod is assumed to be equivalent to two masses at the crank pin and crosshead pin respectively.

3. A connecting rod weighs 105 pounds, distance between centres 33 inches, distance of c.g. from crosshead centre 20 inches, radius of gyration about the c.g. $\sqrt{1.15}$ feet. Find the error in the turning moment caused by the usual assumption, at any crank angle θ , when the engine is making 250 revolutions per minute and its stroke is 11 inches. (L.U.)

4. A horizontal steam engine cylinder has a diameter of 20 inches, stroke 18 inches, connecting rod 3 feet 6 inches between centres, mass of reciprocating parts, including connecting rod, 280 pounds. Find how much the pressure per square inch of the cushion steam must exceed that on the other side of the piston at each end of the stroke, so as to relieve the crank pin brasses of all pressure when the engine is running at 350 revolutions per minute. (L.U.)

5. A compound steam engine develops 600 I.H.P. at 90 revolutions per minute, and from the twisting moment diagram it is found that the fluctuation of energy is 20 per cent. of the energy exerted in one revolution. Find the moment of inertia of the flywheel required, in order that the fluctuation of speed may not exceed 1 per cent.

6. A single-acting Otto cycle gas engine develops 60 I.H.P. at 160 revolutions per minute, with 80 explosions per minute. The change in speed from the beginning to the end of the power stroke must not exceed 2 per cent. of the mean speed. Design a suitable rim section for the flywheel, so that the hoop stress due to centrifugal force does not exceed 600 pounds per square inch. Neglect the effect of the arms, and assume that the work done during the power stroke is $1\frac{1}{2}$ times the work done per cycle. (L.U.)

7. A gas engine, running at a mean speed of 180 revolutions per minute, has a cylinder diameter of 20 inches and stroke 2 feet. The mean pressure during the forward stroke is 120 pounds per square inch gauge; during exhaust stroke, 2 pounds per square inch gauge; during the suction stroke, 1 pound below atmospheric; and during the compression stroke, 40 pounds per square inch gauge. If the resistance on the crank shaft be constant, and the percentage cyclic variation of speed 1.5 per cent., find the moment of inertia of the flywheel required.

CHAPTER XX

BALANCING

244. Centrifugal Force.—Let a body of weight W pounds revolve in a circle of radius r feet, with uniform angular velocity ω radius per second. Then it may easily be shown that the body is subjected to an acceleration $\omega^2 r$ feet per second per second in a direction acting radially inwards towards the centre of the circle. The force acting on the body which gives to it this acceleration is commonly called the *centripetal* force, and must act in the same direction as the acceleration it produces. Hence this force acting *on* the body compelling it to move with uniform speed in a circle is equal to—

$$\frac{W}{g} \omega^2 r \text{ pounds}$$

and it acts in a direction radially inwards.

If, now, the body is connected to the axis of rotation by means of a string or a rigid link, the link will be put in tension, and will itself supply the inward force on the body, and will simultaneously exert an equal and opposite force on the axis of rotation called the *centrifugal* force. Any rotating weight carried at, say, the crank-pin of an engine will therefore put the crank arm in tension, and exert *on the shaft* a force which acts radially outwards, of magnitude

$$\frac{W}{g} \omega^2 r \text{ pounds} \quad (1)$$

This outward force on the shaft is sometimes called the dynamical load on the shaft due to the rotating weight, and may be expressed in terms of revolutions per minute (n) if so desired, since

$$F = \frac{W}{g} \omega^2 r \quad \text{and} \quad \omega = \frac{2\pi n}{60}$$

$$\therefore F = \frac{W}{g} \cdot \left(\frac{2\pi n}{60}\right)^2 r = \frac{\pi^2}{900g} \cdot W n^2 r = 0.00034 W r n^2 \quad . . . (2)$$

EXAMPLE.—The crank arms and crank-pin of a crank-shaft are equivalent to a weight of 800 pounds at a radius of 12 inches. The crank-shaft is supported on bearings 5 feet apart from centre to centre, and the centre of the crank-pin is 2 feet from the left-hand bearing. If the diameter of the shaft is 9 inches, find the dynamical load on the shaft and on its bearings when the shaft is running at 300 revolutions per minute. Find also the loss in friction at each bearing if the coefficient of friction between shaft and bearing be taken as 0.06.

$$\begin{aligned} \text{Total dynamical load on the shaft} &= 0.00034Wrn^2 \\ &= 0.00034 \times 800 \times 1 \times (300)^2 \\ &= 24,480 \text{ pounds} \end{aligned}$$

Two-fifths of this load will evidently act on the right-hand bearing and three-fifths on the left-hand bearing, hence

$$\begin{aligned} \text{dynamical load on right-hand bearing} &= \frac{2}{5} \times 24,480 = 9792 \text{ pounds} \\ \text{,, ,, left-hand ,,} &= 24,480 - 9792 = 14,688 \text{ pounds} \end{aligned}$$

$$\begin{aligned} \text{H.P. lost in friction at right-hand bearing} &= 9792 \times 0.06 \times \frac{\pi \times 9}{12} \times \frac{300}{33,000} \\ &= 12.55 \text{ H.P.} \end{aligned}$$

$$\text{H.P. lost in friction at left-hand bearing} = 12.55 \times \frac{3}{2} = 18.82 \text{ H.P.}$$

245. Dynamical Load on a Shaft due to any Number of Rotating Weights in the Same Plane.—Suppose we have, say, five weights $W_1, W_2, W_3, W_4,$ and W_5 revolving in one plane with uniform angular velocity ω at radii $r_1, r_2, r_3, r_4,$ and r_5 respectively. Each weight will give rise to an outward pull on the shaft, and the total dynamical load will be the vectoral sum

$$(W_1r_1 + W_2r_2 + W_3r_3 + W_4r_4 + W_5r_5) \frac{\omega^2}{g}$$

we may therefore find the vectoral sum ΣWr and, by multiplying by $\frac{\omega^2}{g}$ find the total dynamical load in the shaft.

EXAMPLE.—Suppose we have five weights of 2, 3, 4, 5, and 6 pounds rotating at radii of 1.4, 2, 1.5, 1.75, and 1 foot respectively, the phase

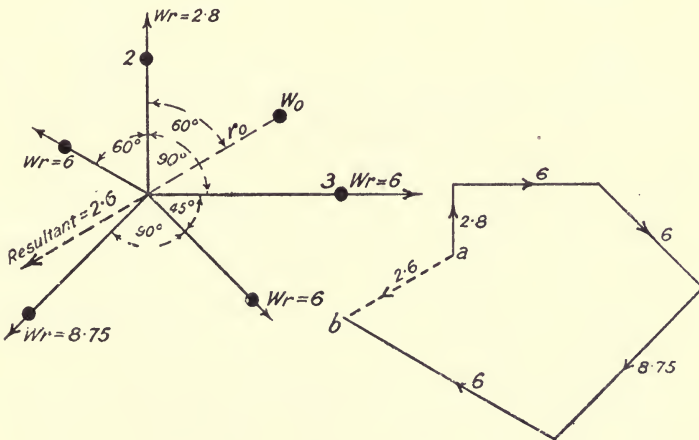

FIG. 214.

angles between the radii being as shown in Fig. 214. Find the resultant dynamical load at ω radius per second.

ΣWr is found by drawing the vector polygon shown in Fig. 214 to any

convenient scale. The sum is 2.6 being represented by ab in magnitude and direction; the total dynamical load will therefore be

$$2.6 \times \frac{\omega^2}{32.2} \text{ pounds}$$

246. Method of Balancing any Number of Rotating Weights in one Plane.—A set of rotating weights in one plane is balanced when the total dynamical load on the shaft is zero, *i.e.* when $\Sigma Wr = 0$, and the force polygon closes. In the above example $\Sigma Wr = ab = 2.6$, hence in order to balance this system of rotating weights it is only necessary to add *one* balance weight W_0 diametrically opposite to the resultant at such a radius r_0 that $W_0 r_0$ is equal to 2.6. This is shown in Fig. 214, the radius r_0 making an angle of 60° with the weight of 2 pounds.

247. Rotating Weights in more than one Plane.—Let there be two equal and diametrically opposite weights W rotating at equal radii r , the distance between the planes of rotation being x (Fig. 215). In this

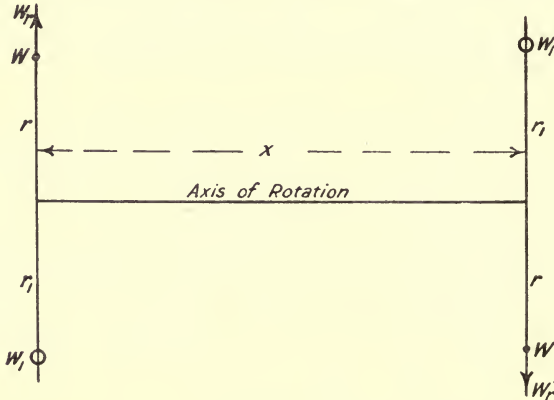

FIG. 215.

case $\Sigma Wr = 0$, the force polygon being a straight line closing upon itself. There will, therefore, be no out of balance force, or dynamical load, on the axis of rotation, but the system will not be in perfect balance because there will be a couple exerted perpendicularly to either plane and proportional to $Wr \times x$. In order to neutralise this couple two rotating balance weights must be added, one in each of *two different planes*. This may conveniently be done by adding a balance weight W_1 diametrically opposite each of the rotating weights such that $W_1 r_1 = Wr$.

The Resultant of a Number of Rotating Weights can be replaced by a Single Force in any Plane, together with a Couple perpendicular to it.—Consider first, a single weight W rotating at radius r in the plane B (Fig. 216). The effect of this weight on any reference plane such as A, distant x from B, is to exert an equal and parallel force at A (proportional to Wr) of magnitude $\frac{W}{g} r \times \omega^2$ and a couple of magnitude $\frac{W}{g} \omega^2 r x$ (proportional to

$Wr x$) tending to cause rotation about an axis through A perpendicular to the reference plane.

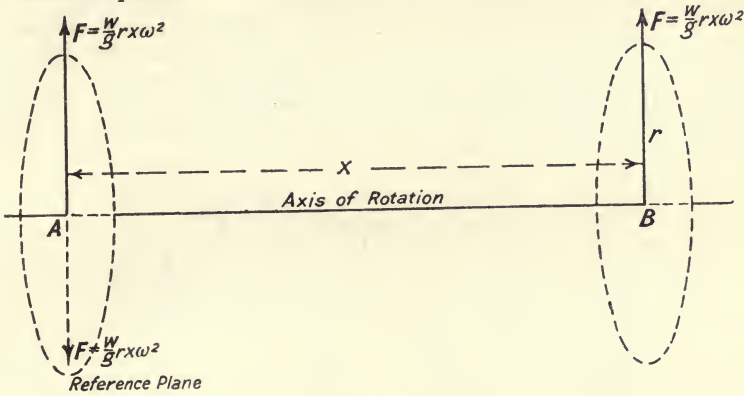

FIG. 216.

Consider next a number of rotating weights, say five, in different planes and choose a reference plane to the left (or right) of these weights (Fig. 217). Find the value of Σwr by drawing the force polygon

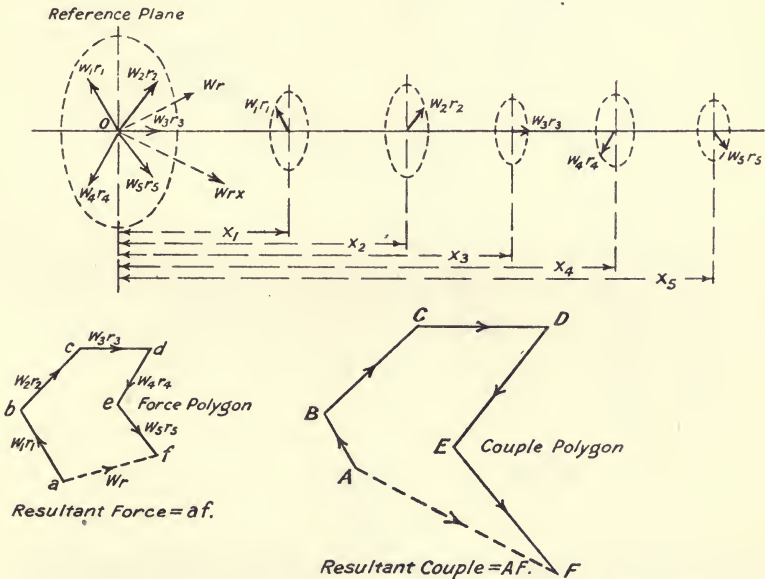

FIG. 217.

$abcdef$ and find the resultant force which is proportional to Wr or af . Next find the resultant couple by drawing the couple polygon $ABCDEF$, each side of which is proportional to $Wr x$, i.e. find the value of $\Sigma Wr x$.

The resultant couple will be represented by AF , and the combined effect of these five rotating weights will be a single force at O proportional to Wr or af , and a couple proportional to Wrx or AF .

If the five rotating weights be in perfect balance amongst themselves it is evident that both the force and the couple polygon will close, and there will be no unbalanced force and no unbalanced couple.

248. Method of Balancing any Number of Rotating Weights in different Planes.—From Art. 247, it will be seen that any number

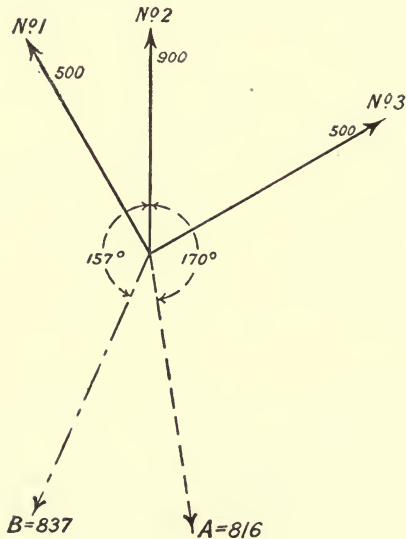
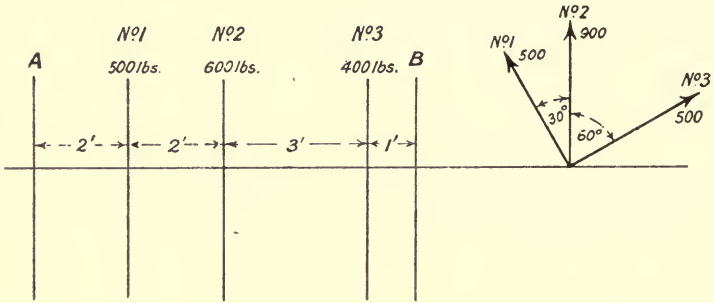

FIG. 218.

of rotating weights may be completely balanced by adding two rotating balance weights, one in each of any two different planes, the conditions required being that—

- (1) The force polygon must close, *i.e.* $\Sigma Wr = 0$.
- (2) The couple polygon must close, *i.e.* $\Sigma Wrx = 0$, the moments being taken about any plane.

If the two planes, say A and B, in which the balance weights are to be placed are given, the method of procedure is as follows :—

Choose one of the planes, say A, as a reference plane, thereby eliminating the couple produced by the balance weight in this plane, and draw the couple polygon ; the closing line will represent the couple which must be exerted by the balance weight in the other plane B. This couple divided by the distance between the two planes will give the force, Wr , required in the plane B. Repeat the construction using B as the reference plane, and find the value of Wr required in the plane A. To test the accuracy of the work choose any other reference plane, and, having put on the balance weights in their proper angular position, draw a new couple polygon. If the work has been carried out accurately this polygon will close. The force polygon will evidently be the same for any plane.

Rule for drawing the Couple Polygons.—If all the rotating masses be on one side of the reference plane the vectors should be drawn radially *outwards* from the axis of rotation. If some of the rotating weights are on one side and some on the other side of the reference plane, the vectors for one side should be drawn radially *outwards*, and for the other side radially *inwards*.

For the Force Polygon all the vectors should be drawn radially *outwards*.

EXAMPLE.—Fig. 218 shows three rotating weights of 500, 600, and

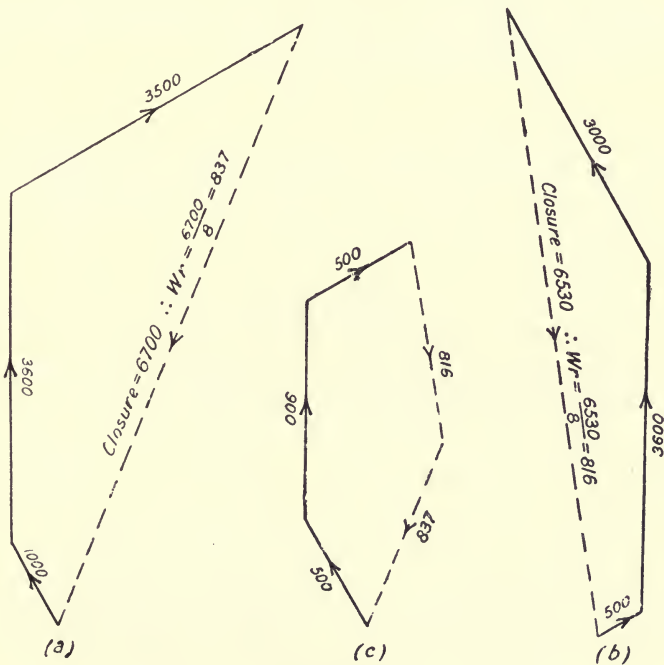

FIG. 219.

400 pounds of radii of 1, 1.5, and 1.25 feet respectively. Find the balance weights required in the planes A and B.

The values of Wr for the three weights are, 500, 900, and 500 respectively. To find the force required in plane B. Choose A as the reference plane and draw the couple polygon (taking moments about A), as shown at (a) Fig. 219. The closing line will be found to scale 6700. Hence the value of Wr for the balance weight in plane B is $\frac{6700}{8} = 837$.

Next taking B as the reference plane draw the couple polygon (taking moments about B), as shown at (b) Fig. 219. The closing line will be found to scale 6530. Hence the value of Wr for the balance weight in plane A is $\frac{6530}{8} = 816$. The accuracy of the work is checked by drawing the force polygon, as shown at (c) Fig. 219.

The angular position of the balance weights are shown in the lower portion of Fig. 218. A balance weight in plane B of 837 pounds at a radius of 1 foot, making 157° with the direction of No. 2, and a balance weight in plane A of 816 pounds at a radius of 1 foot, making 170° with No. 2, would therefore be suitable.

249. Balancing Reciprocating Weights assuming Simple Harmonic Motion. Primary Balancing.—If the connecting rod be infinitely long, the piston moves with simple harmonic motion, its acceleration being

$$\omega^2 x$$

where x is the displacement of the piston from mid-stroke. If r denotes the length of the crank, and θ the crank angle measured from the dead centre, then $x = r \cos \theta$, and the acceleration is

$$\omega^2 r \cos \theta$$

The acceleration of the piston is therefore equal to the resolved part of the centripetal acceleration of the crank-pin ($\omega^2 r$) in the direction of the line of stroke. If W denotes the weight of the accelerating parts per cylinder (estimated as in Arts. 238 and 239), the inertia force for each reciprocating weight is for any crank angle

$$\frac{W}{g} \omega^2 r \cos \theta$$

This force acts along the line of stroke, and is evidently equal to the resolved part of the centrifugal force of a weight W , at a radius r , in the direction of the line of stroke. If, therefore, a rotating weight W be attached to the crank-shaft diametrically opposite to the crank-pin, it will balance the inertia force of the reciprocating weight, and there will be no oscillations in the direction of the line of stroke. On the other hand, the addition of such a rotating weight will be to throw the engine out of balance in a plane perpendicular to the line of stroke, for there will always be the component of the centrifugal force of the rotating weight in the plane. It is therefore evident that a reciprocating weight cannot be perfectly balanced by means of a rotating weight; it can only be balanced by means of another reciprocating weight in the same plane, and always moving in the opposite direction, so that its inertia force balances that of the other reciprocating weight.

In a *vis-à-vis* engine in which the cylinders are on opposite sides of the crank, the connecting rods driving one common crank-pin, the reciprocating

weights for each cylinder will be balanced amongst themselves if the connecting rods are very long and the motion of the pistons simple harmonic.

A two-cylinder engine with cylinders whose centre lines are x apart, and whose cranks are at 180° , will be balanced if the reciprocating weights per cylinder are equal as regards forces, *i.e.* the force polygon will always close, being a straight line closing upon itself, but there will be an out of balance couple due to both rotating and reciprocating masses, as explained in Art. 247.

A number of reciprocating weights in different planes cannot, therefore,

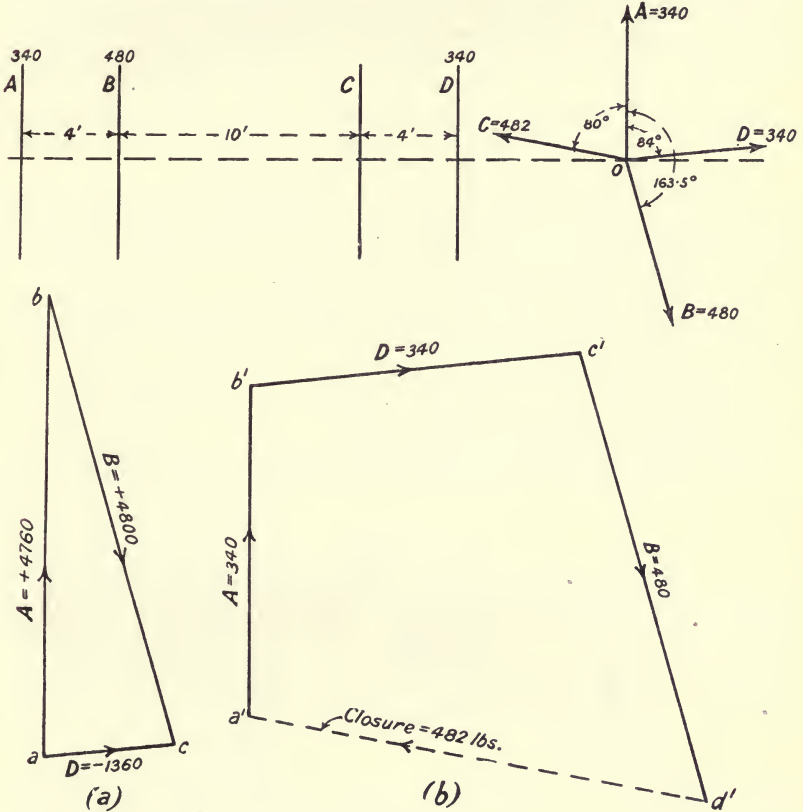

FIG. 220.

be perfectly balanced by rotating weights, but only by adding other reciprocating weights driven by cranks at the correct angles. The general rules for primary balance, *i.e.* when the obliquity of the connecting rod is neglected and simple harmonic motion assumed, are exactly the same as those for rotating weights given in Art. 248, and by suitably arranging the crank angles the reciprocating weights may be arranged to balance themselves, provided there are not less than four of them.

EXAMPLE 1.—In a four-crank engine the distances between the cylinder

centre lines are 4, 10, and 4 feet respectively, reckoned from left to right. Reading from left to right, the reciprocating weights per cylinder are, for crank A 340 pounds, crank B 480 pounds, crank C (not known), and crank D 340 pounds. Find the reciprocating weight required on crank C and the crank angles in order that they may mutually balance.

Take C as the reference plane and draw the couple polygon, making it close (taking moments about C), as shown at (a), Fig. 220. Care must be taken in drawing the vectors in the right direction. A and B are on one side of the reference plane, and the vectors may be drawn outwards; D is on the other side of the reference plane, and it must therefore act *inwards*. Suppose crank A be fixed vertically, then draw ab vertically to represent the couple for A equal to $340 \times 14 = 4760$; for crank B, with centre b and radius equal to the couple $480 \times 10 = 4800$, describe on arc; for crank D, with centre a and radius equal to the couple $-340 \times 4 = -1,360$, describe another arc, cutting the first one in point c . Join bc and ac , this will fix the directions of the cranks B and D; draw OD parallel to ac and OB parallel to bc , and scale off the crank angles.

The crank angle for C and its reciprocating weight may next be found by drawing the force polygon as shown at (b), Fig. 220, drawing each vector radially outwards from the centre of the crank-shaft. Draw $a'b'$ parallel to ab to represent 340 pounds for crank A, $b'c'$ parallel to ac to represent 340 pounds for crank D, $c'd'$ parallel to bc to represent 480 pounds. The closing line $d'a'$, which scales 482 pounds, gives the reciprocating weight required for crank C and its crank angle. From O draw parallel to $d'a'$ and scale of the crank angle. The accuracy of the work may be checked by taking any other reference plane and drawing a new couple polygon which will be found to close.

250. Balancing of Locomotives.—The most common form of locomotive is the two-crank engine, with cranks 90° apart. It has been

shown in Art. 249 that when the cranks are 180° apart, the rotating and reciprocating weights balance themselves as regards forces only; when the cranks are at 90° , however, there will be out of balance forces and couples unless some method is used to balance them. With the two-cylinder engine it is not convenient to add a reciprocating balance weight, and the usual practice is to take two-thirds of the reciprocating weight per cylinder, and all of the out of balance rotating

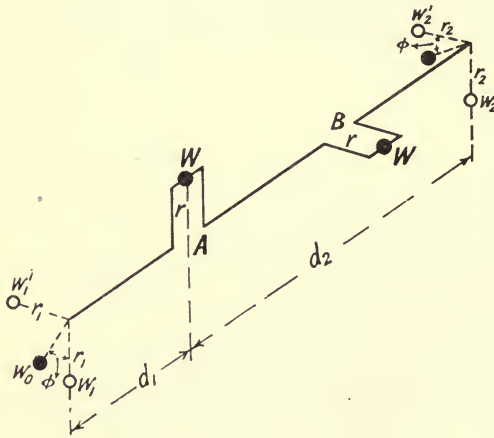

FIG. 221.

weight, and assume that the sum of these two acts at the crank-pin as a rotating weight. The method of balancing rotating weights is then followed as previously explained, the two balance weights being added to the wheels.

The two-crank engine may be conveniently treated analytically as follows:—Let W be the total out of balance weight assumed concentrated at each crank-pin, and r the length of the crank, then referring to Fig. 221 for an inside cylinder engine, we can balance W at crank-pin A by two balance weights w_1 and w_2 arranged diametrically opposite the crank A, such that

$$W \cdot r = w_1 \cdot r_1 + w_2 \cdot r_2$$

and

$$w_1 r_1 d_1 = w_2 r_2 d_2$$

Similarly the weight W at crank-pin B may be balanced by two weights w_1' and w_2' arranged diametrically opposite the crank B.

The two balance weights w_1 and w_1' may then be replaced by a single weight w_0 at the same radius r , such that

$$w_0 = \sqrt{w_1^2 + (w_1')^2}$$

and

$$\tan \phi = \frac{w_1'}{w_1}$$

Similarly for the wheel nearest the crank B a balance weight

$$w_0 = \sqrt{(w_2)^2 + (w_2')^2}$$

will have the same effect as w_2 and w_2' , provided

$$\tan \phi = \frac{w_2'}{w_2}$$

The engine will, of course, only be very imperfectly balanced, since a little consideration will show that there will be for any position of the cranks

- (1) An unbalanced force in the line of stroke.
- (2) An unbalanced force in a vertical plane.
- (3) An unbalanced couple causing swaying from side to side.
- (4) An unbalanced couple which tends to cause oscillations in a vertical plane, in case the centre line of the driving axle is not in the same straight line as the drawbar pull.

EXAMPLE 1.—Estimate the balance weights required for an inside cylinder uncoupled locomotive from the following data:—

Weight of reciprocating parts per cylinder = 600 pounds.

“ rotating “ “ “ = 700 “

Centre lines of cylinders 2 feet apart, length of cranks 13 inches, radius of balance weight circles 2 feet 3 inches. Balance all of the rotating and two-thirds of the reciprocating weights.

Weight to be balanced per cylinder, assumed concentrated at the crank-pin:—

$$= 700 + \frac{2}{3} \times 600 = 1100 \text{ pounds}$$

Consider the left-hand crank. Taking moments about A (Fig. 222), we have

$$w_2 \times 27 \times 60 = 1100 \times 13 \times 18$$

$$w_2 = 159 \text{ pounds}$$

Taking moments about B, we have

$$w_1 \times 27 \times 60 = 1100 \times 13 \times 42$$

$$w_1 = 371 \text{ pounds}$$

$$w_0 = \sqrt{371^2 + 159^2} = 403 \text{ pounds}$$

$$\tan \phi = \frac{159}{371} = 0.429 \quad \therefore \phi = 23^\circ - 10'$$

If the left-hand crank is leading, the required balance weights will therefore be, L.H. wheel 403 pounds, $113^\circ - 10'$ behind R.H. crank, or

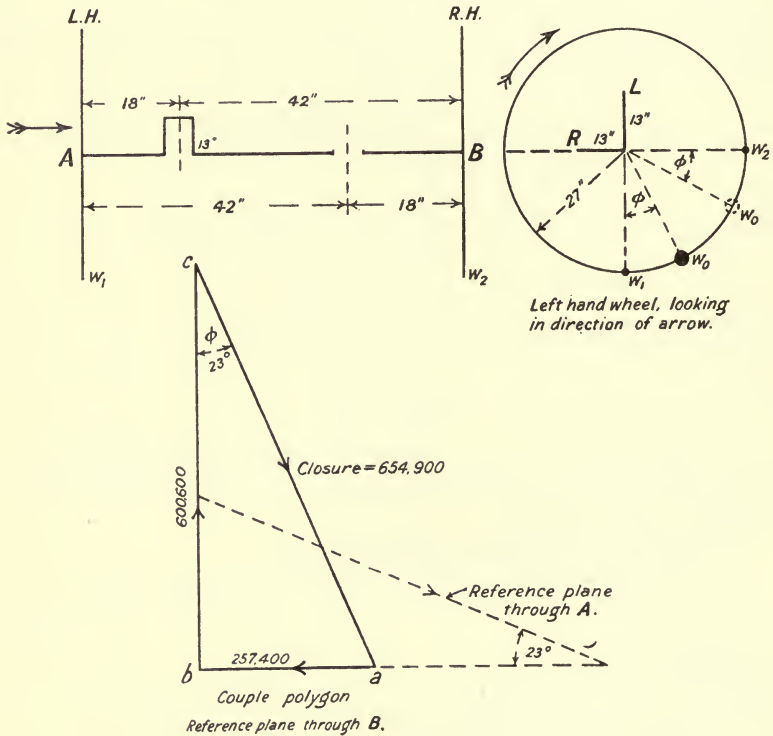

FIG. 222.

$156^\circ - 50'$ in front of L.H. crank, R.H. wheel 403 pounds, $156^\circ - 50'$ in front of R.H. crank shown dotted in Fig. 222.

Graphical Solution.—For balance weight on left-hand wheel, choose the right-hand wheel as a reference plane, and draw the couple polygon as shown in Fig. 222, *i.e.* for R.H. crank make $ab = 1100 \times 13 \times 18 = 257,400$, and for L.H. crank $bc = 1100 \times 13 \times 42 = 600,600$; the closing line ca scales 654,900 and angle $bca = \phi = 23^\circ$.

Hence, if w_0 is the balance weight required,

$$w_0 \times 27 \times 60 = 654,900$$

$$w_0 = 404 \text{ pounds, agreeing with the calculated value.}$$

EXAMPLE 2.—Find the position and amount of the balance weights required for the wheels of a coupled outside cylinder locomotive, the wheel centres being 5 feet, cylinder centres 7 feet 6 inches, and coupling rod centres 9 feet, cranks 13 inches long, radius of balance weights 3 feet. Weight of reciprocating parts per cylinder 500 pounds, and unbalanced rotating parts referred to the crank pin 200 pounds. The weight of each coupling rod is 600 pounds, and the coupling rod crank-pins are in line with the main crank-pins.

Weight to be balanced per cylinder assumed concentrated at crank-pin

$$= 200 + \frac{2}{3} \times 500 = 533 \text{ pounds at crank-pin}$$

$$= \frac{600}{2} = 300 \text{ pounds at coupling rod crank-pin}$$

Driving wheels (see Fig. 223).—In the outside cylinder engine the

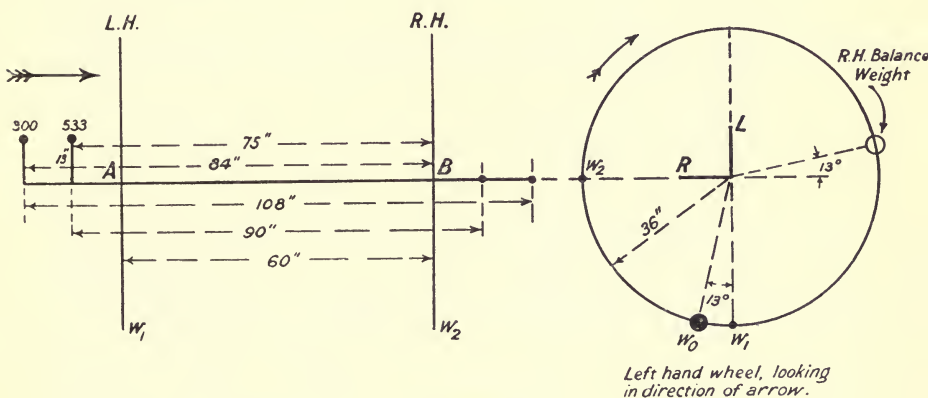

FIG. 223.

weights to be balanced are not all on the same side as the reference plane, hence, considering the left-hand crank, and taking moments about B_1 we have W_1 (opposite L.H. crank),

$$W_1 \times 36 \times 60 = (533 \times 13 \times 75) + (300 \times 13 \times 84)$$

$$\therefore W_1 = 392 \text{ pounds.}$$

Taking moments about A, we have W_2 (in line with R.H. crank) since W_2 is on the opposite side of reference plane through A.

$$W_2 \times 36 \times 60 = (533 \times 13 \times 15) + (300 \times 13 \times 24)$$

$$W_2 = 91.5 \text{ pounds}$$

$$\tan \phi = \frac{91.5}{392} = 0.234 \quad \therefore \phi = 13^\circ 10'$$

$$w_0 = \sqrt{(392)^2 + (91.5)^2} = 403 \text{ pounds}$$

The position of the balance weight for each driving wheel is shown in Fig. 223.

For secondary balancing the latter expression is used, and the inertia force to be balanced is taken as

$$\frac{W}{g} \omega^2 r \left\{ \cos \theta + \frac{\cos 2\theta}{n} \right\}$$

Writing $\theta = \omega t$ and $n = \frac{l}{r}$, this becomes

$$\frac{W}{g} \omega^2 r \left\{ \cos \omega t + \frac{r}{l} \cos 2\omega t \right\} \dots \dots \dots (1)$$

or
$$\frac{W}{g} \left\{ \omega^2 r \cos \omega t + (2\omega)^2 \frac{r^2}{4l} \cos 2\omega t \right\} \dots \dots \dots (2)$$

The first term in (2) represents the projection OA (Fig. 225), on the line

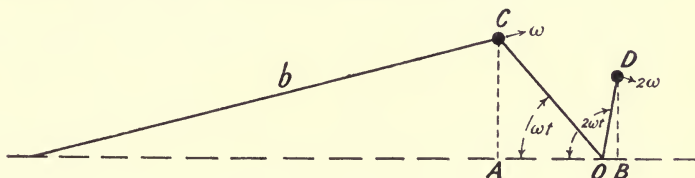

FIG. 225.

of stroke of the inertia force due to a weight W, concentrated at the crank pin C, and rotating at an angular velocity ω . This is known as the primary force.

The second term in (2) represents the projection OB (Fig. 225), on the line of stroke of the inertia force due to a weight W concentrated at an imaginary crank D, of radius $\frac{r^2}{4l}$, and rotating at an angular velocity 2ω in the same plane as the main crank. This is known as the secondary force.

For perfect secondary balancing the conditions will evidently be—

- (1) The primary force polygon must close ($\Sigma W r = 0$).
- (2) The primary couple polygon must close ($\Sigma W r x = 0$).
- (3) The secondary force polygon must close ($\Sigma W \cdot \frac{r^2}{4l} = 0$).
- (4) The secondary couple polygon must close ($\Sigma W \frac{r^2}{4l} \cdot x = 0$).

In a two-crank engine with equal reciprocating weights and cranks at 180° , the *primary forces* are balanced, but the *primary couples* and the *secondary forces* and *couples cannot be balanced*.

A three-crank engine with equal reciprocating weights and cranks at 120° the *primary and secondary forces* may be balanced, but the *primary and secondary couples cannot be balanced*.

A four-crank engine may be arranged to be balanced for *primary and secondary forces and for primary couples*, but not for *secondary couples*.

A five- and six-cylinder engine may be completely balanced for both *primary and secondary forces and couples*.¹

¹ For a complete discussion of secondary balancing, see Professor W. F. Dalby's book on "Balancing of Engines." Edward Arnold.

EXAMPLE 1.—In a three-crank engine the reciprocating weights per cylinder are each equal to 1 ton, and the length of the connecting rod is 4 cranks, the cranks being 120° apart, and 1 foot long. Estimate the out-of-balance primary and secondary couples if the distances between the cylinder centre lines are 3 feet, and the engine runs at 120 revolutions per minute.

The primary and secondary force polygons will evidently close, since each of them will be an equilateral triangle.

Out-of-balance Primary Couple.—Taking I (Fig. 226) as a reference

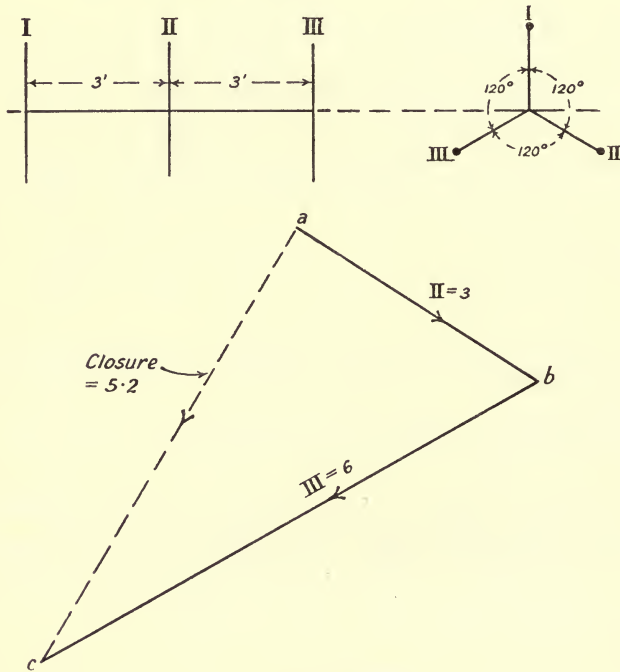

FIG. 226.

plane, we have for crank II $Wr_x = 1 \times 3 = 3$, for crank III $Wr_x = 6$, hence drawing ab parallel to crank II to represent the couple 3, and bc parallel to crank III to represent 6, we find the closing line ac scales 5.2.

Now $\omega = \frac{120}{60} \times 2\pi = 4\pi$ radians per second

$$\begin{aligned} \therefore \text{out-of-balance primary couple} &= (\Sigma Wr_x) \frac{\omega^2}{g} \\ &= \frac{5.2 \times 16\pi^2}{32.2} = 25.7 \text{ tons-feet.} \end{aligned}$$

Out-of-balance Secondary Couple.—The crank angles for the imaginary secondary cranks are shown in Fig. 227. Measured in order in a

clockwise direction from No. I, the angle between Nos. I and II is 240° , and between Nos. I and III 480° . The radius of these cranks is

$$\frac{r^2}{4l} = \frac{1}{16} \text{ foot.}$$

and their angular velocity 2ω or 8π radians per second.

The out-of-balance couple may be most conveniently found by taking, say, I as a reference plane, and assuming unit radius for each secondary crank. This has been done in Fig. 227, and the closing line scales 5.2 (as before).

The out-of-balance secondary couple will therefore be

$$\begin{aligned} & \frac{5.2}{g} \times (2\omega)^2 \times \frac{r^2}{4l} \\ &= \frac{5.2 \times (8\pi)^2 \times 1}{32.2 \times 16} = 6.4 \text{ tons-feet} \end{aligned}$$

EXAMPLE 2.—A two-cylinder vertical engine has its cranks at 180° . The mass of the reciprocating parts for each cylinder is 276 pounds, stroke 18 inches, connecting rod 3 feet 9 inches, distance between centres of cylinders 3 feet, revolutions per minute 354. Assuming that the rotating masses are balanced, draw to a base of crank angles curves representing (1) the alternating force, (2) the alternating couple set up during a revolution (L.U.).

First draw the acceleration curve for one piston, using, say, Klein's construction (Art. 237). This will represent the accelerating force to scale. When the crank is on the inner dead centre $\theta = 0$, the acceleration is $\omega^2 r \left(1 + \frac{1}{n}\right)$, and the accelerating force is $\frac{W}{g} \omega^2 r \left(1 + \frac{1}{n}\right)$.

$$\begin{aligned} \therefore \text{ on inner dead centre } F &= \frac{276}{32.2} \times \left(\frac{2\pi \times 354}{60}\right)^2 \times \frac{9}{12} \left(1 + \frac{9}{45}\right) \\ &= \frac{276}{32.2} \times \frac{(354\pi)^2}{900} \times \frac{3}{4} \times \frac{6}{5} = 10,600 \text{ pounds} \end{aligned}$$

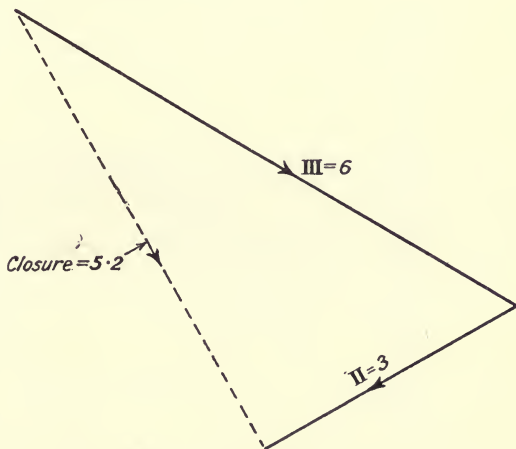
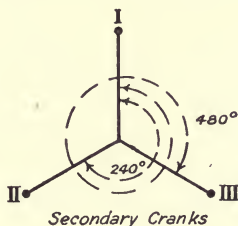

FIG. 227.

The force scale may now be calibrated, since OA represents 10,600 pounds. Draw any line such as OB (Fig. 228) scaling 10.6 units, and

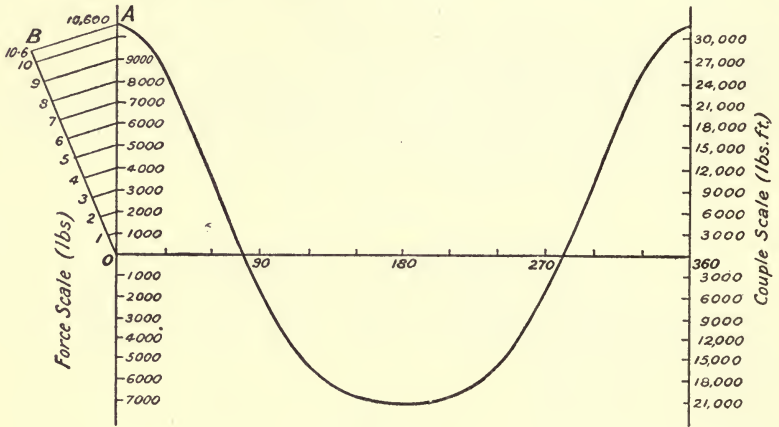

FIG. 228.

divide it into units from O. Join BA, and draw parallels, as shown, which will calibrate the curve for equal intervals of 1000 pounds.

Next draw the curve for the other cylinder as shown in Fig. 229, add

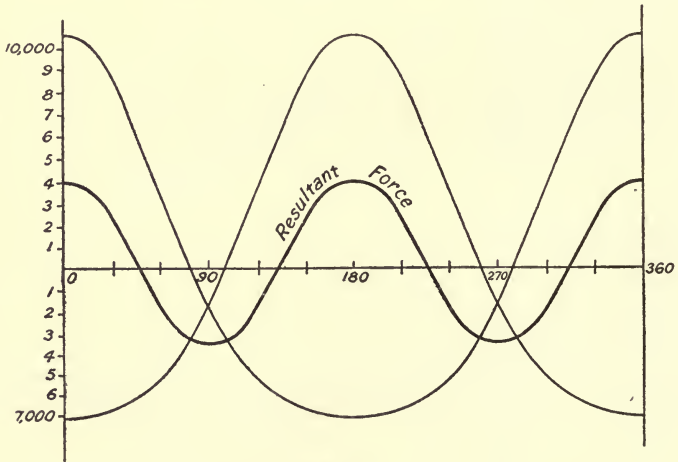

FIG. 229.

the ordinates of the two curves together, and obtain the resulting curve of out-of-balance forces shown.

The alternating couple is

$$\frac{W}{g} \times \text{acceleration} \times \text{distance between cylinders.}$$

The force curve (Fig. 228) will therefore represent the couple to a different scale. The maximum value of the couple is

$$10,600 \times 3 = 31,800 \text{ pound-feet}$$

It should be noted that if the connecting rods were infinitely long, the force curves for the two cylinders would neutralise one another, and the resultant force for all positions of the cranks would be zero, *i.e.* the reciprocating weights would mutually balance as regards forces, but, as already stated, there would still be the out-of-balance couple. The reader should draw similar curves for the case in which the cranks are 90° apart.

EXAMPLES XX

1. A single-cylinder gas engine of stroke 18 inches is fitted with two fly-wheels, one on each side of the crank. The distance between the planes of the wheels is 6 feet, the left-hand wheel being 2 feet from the centre of the crank pin. The rotating weight is 200 pounds at the crank pin and the reciprocating weight 300 pounds. Find the balance weights required on the wheels at 1 foot radius, all of the rotating and two-thirds of the reciprocating weights to be balanced.

2. Four weights of 2, 4, 6, and 8 pounds are rotating in the same plane at 120 revolutions per minute at radii of 1, 1.5, 2, and 1.75 feet respectively. Reckoning in order from the 2-pound weight the phase angles of the different radii are, between 2 and 4, 30° , between 2 and 6, 90° , and between 2 and 8, 210° . Estimate the resultant dynamical load on the shaft, and the position and amount of the balance weight required at a radius of 1 foot.

3. Reckoning from the left in order, let BCD represent the cranks of a three-cylinder engine. The out-of-balance rotating weights are: at B 200 pounds, at C 400 pounds, and at D 250 pounds. The length of each crank is 1 foot. Find the balance weights required in the planes A (to the left of B) and E (to the right of D), given the following distances: between B and C 2 feet, C and D 2 feet, D and E 3 feet, and A and B 4 feet; the crank angles are between B and C 120° , between B and D 240° .

4. In a four-crank engine the distances between the cylinders are all equal. Three reciprocating masses reckoned in succession from the left are $1\frac{1}{2}$, 2, and $2\frac{1}{2}$ tons. Find the fourth reciprocating mass and the crank angles so that the reciprocating masses may mutually balance. (L.U.)

5. Reckoning from the left in order, let ABCDE represent the cranks of a five-cylinder engine. The reciprocating masses are: at A 1 ton, at B 2 tons, and at C 3 tons. The angle between A and B is 90° , and between B and C (in order) 120° . Find the reciprocating masses and the crank angles for D and E in order that they may mutually balance.

6. Find, from the following data, the magnitude and position of the balance weights for an inside cylinder uncoupled locomotive:—radius of crank, 12 inches; radius of balance weights, 33 inches; weight of reciprocating parts of each cylinder, 550 pounds; weight of rotating parts of each cylinder, 500 pounds; cylinder centres, 25.5 inches; wheel centres, 69 inches. All of the rotating and two-thirds of the reciprocating weights to be balanced. (L.U.)

7. From the following data of an outside cylinder uncoupled locomotive calculate the magnitude and position of the balance weights to balance all the rotating and two-thirds of the reciprocating parts:—

Weight of reciprocating parts for each cylinder 500 pounds, weight of rotating parts for each cylinder 600 pounds, cylinder centres 66 inches, wheel centres 56 inches, stroke 24 inches, radius of c.g. of balance weight 30 inches.

Find also the maximum variation in rail pressure when running at 30 miles per hour. Diameter of driving wheels 7 feet. (L.U.)

8. In a three-crank engine the reciprocating weights per cylinder are each equal to 1 ton and the connecting rod is 3.5 cranks long. The distances between the cylinder centre lines are 4 feet, the engine runs at 180 revolutions per minute, and the cranks are 120° apart and 1 foot long. Calculate the out-of-balance primary and secondary couples.

CHAPTER XXI

GOVERNORS

252. Function of the Governor.—The function of the governor is to control the speed of the engine over a long period, or in other words, to keep the speed from varying beyond desired limits when the load on the engine is changed. In the case of a steam engine the governor may be made to actuate a throttle valve in the main steam pipe (throttle governing), or to alter the point of cut-off (cut-off governing). In an internal combustion engine the governor varies the amount of fuel admitted into the engine cylinder to suit the load on the engine. *The governor can only work by a change of speed* which alters the position of the governor balls, such alteration being utilised by a suitable gear in order to vary the amount of working fluid admitted to the cylinder. The cyclic variation in speed due to an uneven turning moment on the crankshaft is controlled solely by the flywheel, as already mentioned (Art. 243).

253. The Watt Governor.—The early Watt governor is shown diagrammatically in Fig. 230. The vertical governor spindle is driven by the engine, thus causing the two balls to rotate in a circle. In order to make the balls rotate in a circle, a force must act radially inwards on each ball (Art. 244) of amount $\frac{w}{g}\omega^2r$; this force is supplied by the combined action of the weight of the ball (w lbs.) and the tension (T lbs.) of the supporting arm. Referring to Fig. 230, let the angular velocity of the ball be constant and equal to ω radians per second, then there are *two* forces acting on the ball, viz. its own weight w acting vertically downwards, and the tension T of the supporting arm.

Let r = the radius of the ball circle in feet,
 h = height of the governor in feet.

The sum or resultant of T and W is shown in the lower part of Fig. 230, where $ab = T$ and $bc = W$; the horizontal line ac represents the centripetal force F , *i.e.* the vectorial sum of T and W acting on the ball and making it rotate with uniform speed in a circle; its magnitude is evidently $\frac{W}{g}\omega^2r$ pounds.

The two triangles ABC and abc are similar, hence

$$\frac{BC}{CA} = \frac{bc}{ca}$$

i.e. $\frac{h}{r} = \frac{w}{F}$ or $F = w \cdot \frac{r}{h} \dots \dots \dots (1)$

$$\text{or } \frac{h}{r} = \frac{w_s}{w\omega^2 r} = \frac{g}{\omega^2 r}$$

$$\therefore h = \frac{g}{\omega^2} \dots \dots \dots (2)$$

If $n =$ revolutions per minute, then $\omega = \frac{2\pi n}{60} = \frac{\pi n}{30}$ and

$$h = \frac{g \times 900}{\pi^2 n^2} = \frac{32.2 \times 900}{\pi^2} \cdot \frac{1}{n^2}$$

$$\text{or } h = \frac{2937}{n^2} \text{ feet} \dots \dots \dots (3)$$

$$= \frac{2937 \times 12}{n^2} = \frac{35240}{n^2} \text{ inches} \dots \dots \dots (4)$$

The height of the governor is therefore inversely proportional to the square of the angular velocity.

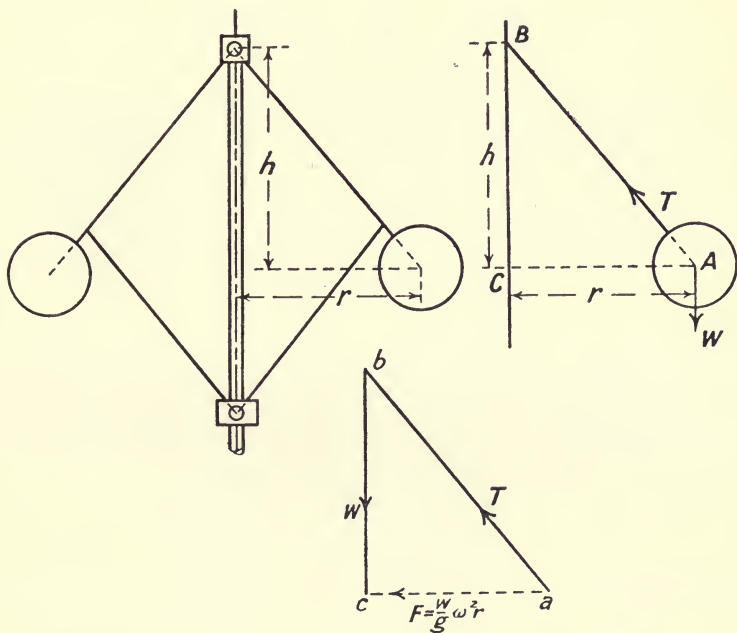

FIG. 230.

Let $h_1 =$ height when the angular velocity is ω_1
 and $h_2 =$ " " " " " changes to ω_2

Then from (2) above

$$\frac{h_1}{h_2} = \frac{g}{\omega_1^2} \div \frac{g}{\omega_2^2} = \frac{\omega_2^2}{\omega_1^2}$$

and the change in height is

$$h_1 - h_2 = g \left(\frac{1}{\omega_1^2} - \frac{1}{\omega_2^2} \right)$$

If, therefore ω_1 and ω_2 denote the two extreme speeds permissible, the change in height $h_1 - h_2$ must be sufficient to actuate the gear required. At high speeds the change in h or the movement of the governor sleeve rapidly falls off as the speed increases, as will be evident from the following:—

<i>n.</i>	$h = \frac{354.20}{n^2}$	Change in <i>h</i> (inches).
60	9.79	2.507
70	7.193	1.686
80	5.507	1.156
90	4.351	0.827
100	3.524	1.074
120	2.450	0.652
140	1.798	0.423
160	1.375	0.288
180	1.087	0.206
200	0.881	

A change in speed from 180 to 200 revolutions per minute only changes the height (neglecting friction) 0.206 inch, and, further, the height at the latter speed is only 0.881 inch. On the other hand, a smaller change from 60 to 70 revolutions per minute changes the height 2.5 inches. It will be evident, therefore, that this type of governor is not suitable for high speeds, and, further, the power of the governor, or the work it can do on the governor sleeve, is very small, being only equal to

$$2w \times \text{extreme variation in } h.$$

254. The Porter Governor.—The power of a Watt governor is greatly increased by adding a dead weight to the governor sleeve as in the Porter governor (Fig. 231). Before any movement of the sleeve can occur, this dead load must be lifted, and this necessitates a higher speed of rotation of the balls in order to obtain the required lifting force at the sleeve.

- Let w = weight of each ball in pounds,
- W = dead load on the sleeve in pounds,
- k = $\frac{\text{vertical movement of the sleeve}}{\text{vertical movement of the balls}}$

then each ball has to lift a total equivalent weight of $w + \left(\frac{W}{2}\right)k$ pounds, and by the same reasoning as before, the centrifugal force F per ball must be

$$F = \left(w + \frac{Wk}{2} \right) \cdot \frac{r}{h}$$

$$\frac{w}{g} \omega^2 r = \left(w + \frac{Wk}{2} \right) \frac{r}{h}$$

$$h = \frac{w + \frac{Wk}{2}}{\frac{w}{g} \omega^2} \dots \dots \dots (1)$$

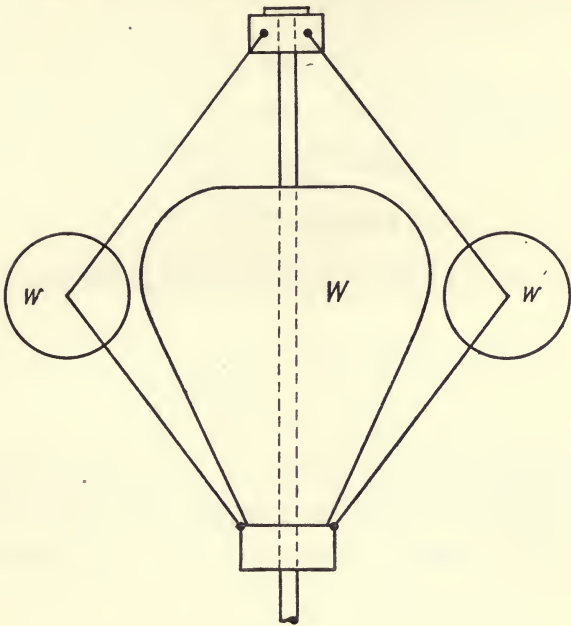

FIG. 231.

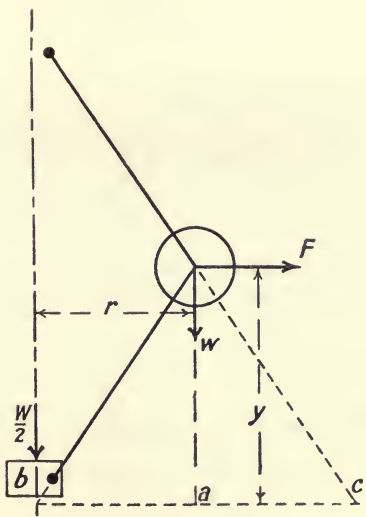

FIG. 232.

In the Porter governor, as usually constructed, all the links are equal in length, and therefore $k = 2$, and

$$h = \frac{w + W}{w} \cdot \frac{g}{\omega^2} \dots \dots \dots (2)$$

Expressing this in terms of revolutions per minute, we have

$$h = \frac{w + W}{w} \cdot \frac{g \times 900}{\pi^2 n^2}$$

$$h = \frac{2937}{n^2} \cdot \frac{w + W}{w} \dots \dots \dots (3)$$

or in order to run at a height of h feet, the speed in revolutions per minute must be

$$n^2 = \frac{2937}{h} \cdot \frac{w + W}{w}$$

$$n = 54.19 \sqrt{\frac{w + W}{w} \cdot \frac{1}{h}} \dots \dots \dots (4)$$

An alternative method of treating the theory of this governor is to reduce it to a statical problem by inserting a hypothetical *outward* force on the ball, which we will call the controlling force, equal to the inward force $F = \frac{w}{g} \omega^2 r$. Taking moments about point C (Fig. 232) we have

$$F \times y = w \times ac + \frac{W}{2} \times bc$$

With equal links $y = h$, $ac = r$, and $bc = 2r$

$$\therefore Fh = wr + Wr$$

$$\text{or } Fh = (w + W)r$$

$$\text{or } F = \frac{W + w}{w} \cdot \frac{r}{h} \dots \dots \dots (5)$$

and since $F = \frac{w}{g} \omega^2 r$

$$\frac{w}{g} \omega^2 r \cdot h = (w + W)r$$

$$h = \frac{w + W}{w} \cdot \frac{g}{\omega^2} \text{ as before.}$$

Effect of Friction.—The effect of friction in the governor mechanism is usually measured as a force, say f pounds, at the sleeve, opposing motion of the sleeve. Then, if the speed increases and the height does not alter

$$h = \frac{W + w + f}{w} \cdot \frac{g}{\omega^2} \dots \dots \dots (6)$$

But if the speed decreases and the height does not alter

$$h = \frac{W + w - f}{w} \cdot \frac{g}{\omega^2} \dots \dots \dots (7)$$

hence
$$\frac{\omega_1^2}{\omega^2} = \frac{W + w \pm f}{W + w} = 1 \pm \frac{f}{W + w} \dots \dots \dots (8)$$

Equation (8) gives the relation between the two extreme speeds and the mean speed which will not cause any change in the position of the governor balls on account of frictional resistance.

EXAMPLE 1.—The balls of a Porter governor weigh 6 pounds each, and the central weight is 100 pounds. Calculate the height to which the balls will rise when running at 200 revolutions per minute if the resistance on the sleeve due to moving the governor gear is 5 pounds. How much must the speed decrease before the balls begin to descend?

$$\omega = 200 \times \frac{2\pi}{60} = \frac{20\pi}{3} \text{ radians per second}$$

$$\text{By (6)} \quad h = \frac{100 + 6 + 5}{6} \cdot \frac{g \times 9}{(20\pi)^2}$$

$$\therefore h = 1.323 \text{ feet}$$

When the balls start to descend we have the relation from (6)

$$\frac{W + w + f}{w} \cdot \frac{g}{\omega_1^2} = \frac{W + w - f}{w} \cdot \frac{g}{\omega_2^2}$$

$$\frac{111}{6} \cdot \frac{g}{\omega_1^2} = \frac{101}{6} \cdot \frac{g}{\omega_2^2}$$

i.e.

$$\frac{\omega_1^2}{\omega_2^2} = \frac{111}{101}$$

and

$$\frac{n_1^2}{n_2^2} = \frac{111}{101}$$

$$\begin{aligned} n_2 &= n_1 \sqrt{\frac{101}{111}} \\ &= 200 \sqrt{0.91} \\ &= 190.8 \text{ revolutions per minute} \end{aligned}$$

EXAMPLE 2.—The balls of a Porter governor weigh 4 pounds each, the load on the governor is 40 pounds, and the arms intersect on the axis. At what height will this governor run if it revolves at 240 revolutions per minute? If the speed of the balls is suddenly increased 2.5 per cent., what pull will be exerted on the gearing attached to the governor sleeve? If the friction of the regulating apparatus is equal to a dead load on the sleeve of 5 pounds, by how much must the speed increase before the balls begin to rise? (L.U.)

$$\omega = 240 \times \frac{2\pi}{60} = 8\pi \text{ radians per second}$$

$$h = \frac{40 + 4}{4} \times \frac{g}{64\pi^2} = 0.558 \text{ foot or } 6.7 \text{ inches}$$

when the speed suddenly increases to 1.025ω

$$h = \frac{40 + 4}{4} \cdot \frac{g}{\omega^2} = \frac{44 + x}{4} \cdot \frac{g}{(1.025\omega)^2}$$

from which $x = 2.2$ pounds.

Let ω_1 be the speed at which the ball begins to rise, then

$$h = \frac{44}{4} \cdot \frac{g}{\omega^2} = \frac{44 + 5}{4} \cdot \frac{g}{\omega_1^2}$$

$$\frac{\omega_1^2}{\omega^2} = \frac{49}{44} = 1.112$$

or $\frac{n_1}{n} = \sqrt{1.112} = 1.056$

$$\begin{aligned} \therefore n_1 &= n \times 1.056 \\ &= 240 \times 1.056 \\ &= 254 \text{ revolutions per minute, } i.e. \text{ an increase of } 5.6 \text{ per cent.} \end{aligned}$$

EXAMPLE 3.—In an ordinary Porter governor, suppose the frictional resistance reduced to the sleeve to be 15 pounds, dead load 100 pounds, and the weight of each ball 3 pounds. Find the change in position of the sleeve as the speed respectively rises 5 per cent. above or falls 5 per cent. below the normal speed which is 200 revolutions per minute.

At 210 revs. $\omega = 210 \times \frac{2\pi}{60} = 7\pi$ radians per second

At 190 revs. $\omega = 190 \times \frac{2\pi}{60} = 19\frac{\pi}{3}$ radians per second

At the normal speed of 200 revs. $\omega = 200 \times \frac{2\pi}{60} = \frac{20\pi}{3}$ radians per second.

If the governor *rises through a speed* from 200 to 210 revs.

$$h_{200} = \frac{100 + 3 + 15}{3} \cdot \frac{g \times 9}{400\pi^2} = 2.860 \text{ feet}$$

and $h_{210} = \frac{100 + 3 + 13}{3} \cdot \frac{g}{49\pi^2} = 2.594 \text{ feet}$

Hence, for the 5 per cent. increase in speed the change in height is

$$2.860 - 2.294 = 0.266 \text{ foot or } 3.192 \text{ inches}$$

N.B.—If, however, the speed was falling at the instant the balls were rotating at 200 revolutions per minute, an increase in the speed of 5 per cent. would not move the sleeve.

If the governor *falls through a speed* from 200 to 190 revs.

$$h_{200} = \frac{100 + 3 - 15}{3} \cdot \frac{g \times 9}{400\pi^2} = 2.133 \text{ feet}$$

and $h_{190} = \frac{100 + 3 - 15}{3} \cdot \frac{g \times 9}{361\pi^2} = 2.363 \text{ feet}$

Hence, for the 5 per cent. decrease in speed the change in height is

$$2.363 - 2.133 = 0.23 \text{ foot or } 2.76 \text{ inches}$$

The rise or fall of the balls may therefore be 3.19 inches and 2.76 inches respectively, or anything less according to the position of the above

at 200 revolutions, which may vary from that due to a height of 2.86 feet to that of 2.133 feet.

255. Modified Proell Governor.—Another form of loaded governor is shown diagrammatically in Fig. 233. A general statical theory of this governor may be given as follows:—

As before let w be the weight of each ball and W the weight of the

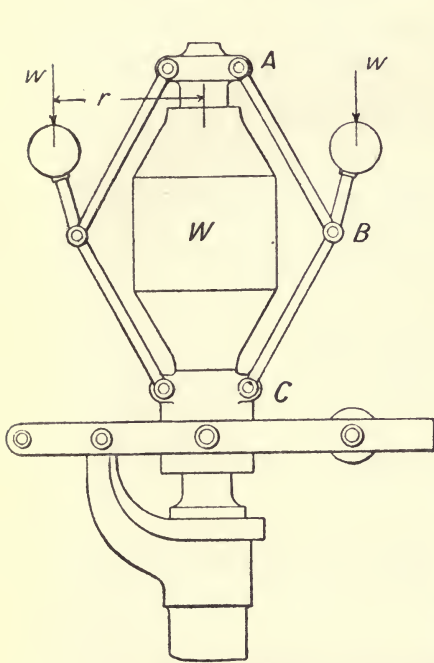

FIG. 233.

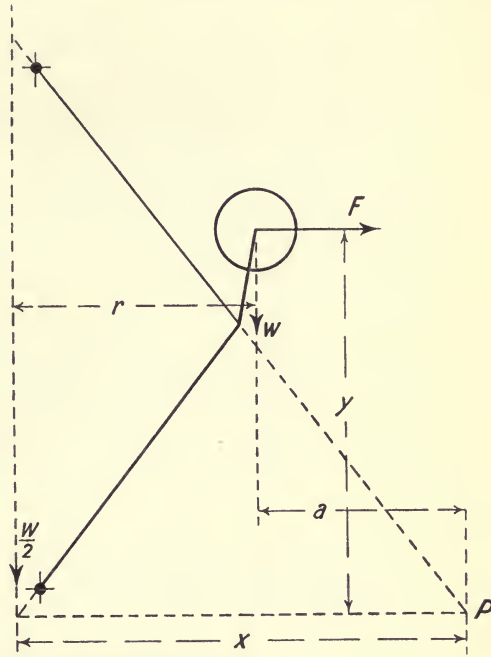

FIG. 234.

central load, then, considering one side of the governor only and taking moments about point P (Fig. 234) we have

$$F \times y = \frac{W}{2} \times x + w \times a \dots \dots \dots (1)$$

where F is the horizontal outward force known as the *controlling force*, which would have to be applied to the ball when at rest in order to maintain it at radius r . Neglecting friction F will be numerically equal to the centrifugal force, *i.e.*

$$F = \frac{w}{g} \omega^2 r$$

$$\therefore \frac{w}{g} \omega^2 r \times y = \frac{W}{2} \cdot x + w_1 a$$

$$\omega^2 = \frac{(W \cdot x + 2wa)g}{2wry} \dots \dots \dots (2)$$

or, expressing this in revolutions per minute (n)

$$\left(\frac{2\pi n}{60}\right)^2 = \left(\frac{Wx + 2wa}{2wry}\right)g$$

$$n^2 = \frac{900g}{\pi^2} \times \frac{Wx + 2wa}{2wry}$$

$$n^2 = 2937 \frac{Wx + 2wa}{2wry} \dots \dots \dots (3)$$

For any position of the balls (3) will give the speed at which (neglecting friction) the governor must rotate.

In the usual design of this governor the links AB and BC (Fig. 233) are equal and at the normal speed the arm carrying the ball is vertical. The actual movement of each ball on either side of this mean position is small and may without serious error be assumed horizontal.

In this case, therefore, it is evident that $a = r$, and $x = 2r$ and (2) becomes

$$\omega^2 = \frac{(W \cdot 2r + 2wr)g}{2wry}$$

$$\omega^2 = \frac{W + w}{w} \cdot \frac{g}{y} \dots \dots \dots (4)$$

or

$$n^2 = \frac{2937}{y} \cdot \frac{W + w}{w} \dots \dots \dots (5)$$

The power of this governor may be expressed in the same terms as that of the Porter governor, namely,

Weight of both balls \times extreme vertical movement of balls (if any)

+ central load \times extreme lift of sleeve,

or $2(\text{mean centrifugal force per ball} \times \text{range through which this force acts})$

i.e. $2\left\{\frac{w}{g}\omega^2r(r_1 - r_2)\right\}$

where ω = mean angular velocity,
 r = mean radius,
 r_1 and r_2 the greatest and least radius of the ball circles respectively.

256. Stability and Sensitiveness of a Governor—Hunting.—

A governor is said to be stable when it takes up a definite position for a definite speed, or in other words, for a definite change of speed a stable governor changes its position by a definite amount. For this condition to exist it is essential that the horizontal controlling force (F) on the balls must change more rapidly than the radius of the ball circle, since the centrifugal force is directly proportional to the radius.

If a small change δr in the radius produces a change δF in the force, stability is assured providing

$$\frac{\delta F}{F} > \frac{\delta r}{r}$$

or

$$\frac{dF}{F} > \frac{dr}{r} \quad \text{or} \quad \frac{dF}{dr} > \frac{F}{r}$$

i.e. the rate of change of the controlling force is greater than that of the radius.

In the case of the unloaded Watt governor $F = w \cdot \frac{r}{h}$ ((1) Art. 253), in the Porter governor $F = \frac{W + w}{w} \cdot \frac{r}{h}$ ((5) Art. 254). Now W and w are constant, and in both of these cases it is evident that h must *decrease* as r *increases*, and that therefore F must increase faster than r , *i.e.* $\frac{dF}{dr} > \frac{dr}{r}$ and stability is assured.

If in any case $\frac{dF}{F} = \frac{dr}{r}$ the governor would only have one speed of rotation for any position of the balls. Such a governor would be useless in practice because the most minute change in speed would cause the balls to fly from one extreme position to another. Such a governor is said to be *isochronous*.

Sensitiveness.—Throughout the complete range of the governor, or any

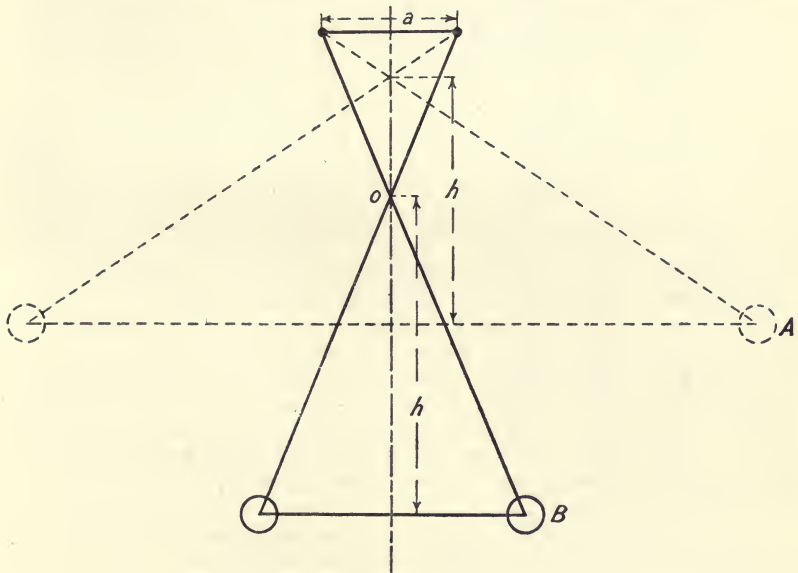

FIG. 235.

part of the range there must be a definite change in the speed. If the change is small the governor is sensitive. The sensitiveness of a governor

is therefore proportional to the sleeve lift for a given change in speed, and is usually defined as the ratio of the variation in speed to the mean speed, *i.e.* as

$$\frac{n_1 - n_2}{n}$$

where n_1 and n_2 are the greatest and least speeds respectively and n the mean speed of the engine.

An isochronous governor is infinitely sensitive since it has only one speed for equilibrium. Many governors are approximately isochronous, being at the same time stable and very sensitive, and designed so that F increases very little faster than r .

The Watt governor may be made more sensitive by crossing the arms as shown in Fig. 235. In this case the point of suspension is virtually at O , the point of intersection of the arms, and any desired relation between the rates of variation of F and r may be obtained. In some position such as A the governor is stable since h decreases as r increases, whereas in another position such as B the governor is unstable since h will increase as r increases, and therefore $\frac{dF}{F}$ will be less than $\frac{dr}{r}$. There will always be

some intermediate position in which $\frac{dF}{F} = \frac{dr}{r}$ and the governor will then be isochronous and infinitely sensitive. By suitably arranging the distance a and the length of the arms the path of the balls can be made a parabola, in which case h (the subnormal to the parabola) will be constant and the governor isochronous. Stability can be obtained by making the distance a a little less than that which gives isochronism, and to make the governor more powerful the sleeve may be loaded as is done in the case of the Porter governor.

Hunting is a state of forced vibration in the engine speed produced by a too sensitive governor. In deciding upon the degree of sensitiveness to adopt for the governor, due regard must be paid to the cyclic variation in speed which is allowed by the flywheel (Art. 243). If the cyclic variation

is less than the sensitiveness of the governor $\left(\frac{n_1 - n_2}{n}\right)$ then the governor is stable; if, however, the cyclic variation is greater than the sensitiveness it will be evident that the governor will be continually oscillating in response to the cyclic changes in speed of the engine, giving rise to "hunting." In the case of an internal combustion engine the governor will not, as a rule, work equally well on all loads. The flywheel and governor will normally be designed for about full load on the engine, so that at the load usually maintained the cyclic variation in speed is less than the sensitiveness of the governor and hunting will not take place. On light load, however, the cyclic variation may be greater than the sensitiveness, and with a sensitive governor hunting will occur.

From the above it will be evident that very sensitive governors are only required for the very close regulation in speed required for electric driving and similar work, in which case the cyclic variation in speed is necessarily very small and the sensitiveness of the governor can be made very low without causing the engine to hunt. In cases where the cyclic variation need not be very small a very sensitive governor is unnecessary, because

the flywheel effect will be too small for the governor, or in other words, the cyclic variation may be greater than the sensitiveness and the governor will be continually hunting.

In the case of a compound steam engine governed by throttling, if the governor is too sensitive it will be evident that, apart from the flywheel effect, a small increase in speed will cause the governor to close the throttle; but this will take time, and before the closing is completed the engine *must* have stored a little excessive energy and more steam than is required will have passed the throttle. The extra amount of steam will continue expanding through the low-pressure cylinder after it has done work in the high-pressure cylinder, with the result that the engine speed will accelerate for a time and the governor will close the throttle still further. After this extra steam has passed through the engine the speed will fall and the governor will open the throttle, but while it is doing so the speed will be falling with the result that the throttle will be opened further than is required, and in a short time the engine will again accelerate. A too sensitive governor will therefore alternately open and close the throttle too much and set up hunting.

The inertia of the governor balls will also assist a too sensitive governor in producing hunting by making the balls overshoot their new position when the speed suddenly changes. This may be prevented and an approximately isochronous governor may be made as sensitive as required, without hunting, by fitting a dash pot to it which prevents a *too sudden change in position* of the governor sleeve, but has practically no effect when the change is gradual.

257. Spring Loaded Governors.—Hartnell Governor.—A small governor may be made very powerful and at the same time as

sensitive as required by loading the sleeve by means of a strained spring instead of a dead weight. The Hartnell governor is shown in Fig. 236. A cap C fixed to the central spindle and driven by bevel wheels, carries bell crank levers L with a ball of weight w pounds at one end and a roller acting on a loose sleeve B at the other end of each lever. The cap is made hollow and contains a spring S which, when in compression, presses downwards on the sleeve B. As the engine speed increases the balls fly out until the centrifugal force is balanced by the compressive load on the spring. When the engine is running at its normal speed the

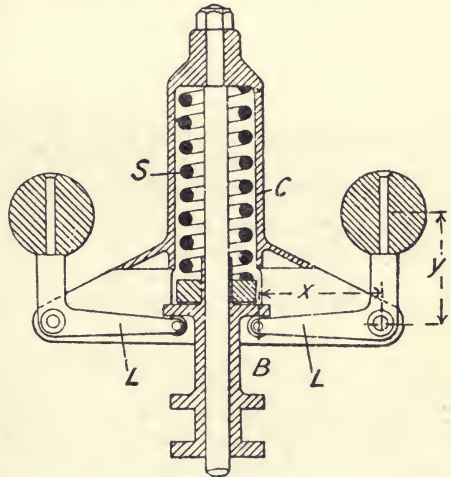

FIG. 236.

arms of the bell crank levers carrying the balls are usually arranged to be vertical and the total movement of the balls being small it is usual to assume that the balls move out horizontally in a radial direction.

Let r be the radius of the ball circle at speed ω radians per second, and F the outward controlling force on each ball which, when the governor is at rest, will keep the balls at this radius, then, taking moments about the fulcrum and neglecting friction we have, for each ball, force on sleeve

$$\begin{aligned} \text{balanced by the spring} &= F \times \frac{y}{x} \\ &= \frac{w}{g} \omega^2 r \cdot \frac{y}{x} \text{ pounds} \end{aligned}$$

$$\text{and for both balls load} = 2 \frac{w}{g} \omega^2 r \cdot \frac{y}{x} \text{ pounds}$$

If r_1 and r_2 be the two extreme radii of the balls when running at speeds ω_1 and ω_2 respectively, the change in load on the spring will be

$$2 \frac{w}{g} \cdot \frac{y}{x} (\omega_1^2 r_1 - \omega_2^2 r_2) \text{ pounds}$$

The spring must be made of the required stiffness in order that when given a certain initial compression the above change in the load on it will allow the necessary movement of the governor sleeve.

EXAMPLE 1.—A spring loaded governor of the type shown in Fig. 236 is provided with balls, each weighing 6 pounds. The arms of the bell crank levers carrying the balls are $x=4$ inches and $y=5$ inches. Neglecting the effect of the obliquity of the lever arms and the mass of the levers, find the pull exerted on the governor sleeve by the balls when the governor is driven at 300 revolutions per minute. Find the strength of the spring so that the governor will revolve steadily at the configuration shown in Fig. 236 and also in a configuration determined by a vertical movement of the sleeve of 0.2 of an inch when the speed increases 5 per cent.

$$\text{At 300 revs. per min. } \omega = 300 \times \frac{2\pi}{60} = 10\pi \text{ radians per second}$$

$$\therefore \text{controlling force per ball } F = \frac{6}{32.2} \times 100\pi^2 \times \frac{4}{12} = 61.3 \text{ pounds}$$

$$\text{load on the sleeve} = 2 \times 61.3 \times \frac{5}{4} = 153.5 \text{ pounds}$$

For a vertical rise of 0.2 inch of the sleeve the radius of the ball circle will increase $0.2 \times \frac{5}{4} = 0.25$ inch.

Hence the radius when the speed increases 5 per cent., *i.e.* when $\omega = 10\pi \times 1.05$ is 4.25 inches and

$$F = \frac{6}{32.2} \times (10.5\pi)^2 \times \frac{4.25}{12} = 71.8 \text{ pounds}$$

$$\therefore \text{load on sleeve} = 2 \times 71.8 \times \frac{5}{4} = 179.5 \text{ pounds.}$$

Hence a 5 per cent. increase of speed increases the load on the sleeve, and therefore on the spring, by an amount

$$179.5 - 153.25 = 26.25 \text{ pounds}$$

this compresses the spring 0.2 inch, hence the stiffness of spring required is $\frac{26.25}{0.2} = 131.25$ pounds per inch compression.

EXAMPLE 2.—In the governor shown diagrammatically in Fig. 237 the strength of the spring is such that a force of 200 lbs. is required to stretch it 1 inch. In the position shown the balls are against the stops and the initial compression of the spring is 110 pounds, and the weight of each ball is 5 pounds. Assuming that the balls move in a horizontal plane and that all control is effected by the spring, at what speed will the balls revolve at a radius of 5 inches? Is the governor stable?

When the radius of the ball circle increases from 2.5 to 5 inches, the downward movement of the sleeve will be

$$2.5 \times \frac{3}{8} = 1.25 \text{ inches}$$

This movement will put the spring in tension to the amount of

$$1.25 \times 200 = 250 \text{ pounds}$$

The spring, however, is initially in compression to the amount of 110 pounds. Hence at a radius of 5 inches the tension of the spring is

$$250 - 110 = 140 \text{ pounds}$$

The controlling force on each ball is therefore $\frac{1}{2} \times \frac{140}{2} = 35$ pounds.

$$\therefore \frac{5}{32.2} \times \omega^2 \times \frac{5}{12} = 35$$

$$\omega^2 = \frac{35 \times 32.2 \times 12}{25} = 541$$

$$\omega = 23.26 \text{ radians per second}$$

$$n = \frac{23.26 \times 60}{2\pi} = 222 \text{ revs. per min.}$$

An increase of 1 inch in the radius moves the sleeve 0.5 inch and changes the load on the spring $200 \times 0.5 = 100$ pounds. Hence the corresponding change in the controlling force per ball is $\frac{100}{4} = 25$ pounds.

$$\therefore \frac{dF}{dr} = \frac{25}{1}$$

At a radius of 5 inches $F = 35$ pounds.

$$\therefore \frac{F}{r} = \frac{35}{5} = 7$$

The governor is therefore stable since $\frac{dF}{dr} > \frac{F}{r}$.

EXAMPLE 3.—What must be the initial load on the spring in Example 2 in order that the governor may be isochronous, and what will then be the equilibrium speed of the governor?

$$\text{For isochronism } \frac{F}{r} = \frac{dF}{dr} = 25$$

$$\therefore \text{at the radius of 5 inches } \frac{F}{5} = 25$$

$$F = 125 \text{ pounds}$$

This controlling force per ball will put a tension on the spring of

$$4 \times 125 = 500 \text{ pounds}$$

It has been shown in the solution to Example 2 that the movement of the sleeve puts the spring in tension to the extent of 250 pounds, hence the initial *tension* of the spring must be $500 - 250 = 250$ pounds.

Let ω_1 = equilibrium speed of the governor

$$\begin{aligned} \frac{5}{32 \cdot 2} \times \omega_1^2 \times \frac{5}{12} &= 125, \\ \omega_1^2 &= 1931 \\ \omega_1 &= 43 \cdot 8 \text{ radains per second} \\ \text{or} &= 420 \text{ revs. per minute} \end{aligned}$$

A modification of the Hartnell governor is shown in Fig. 237. In this type the revolving weights, or balls, are carried on bell crank levers and rotate with the engine crankshaft, being tied together by means of a spring or springs. The engine speed can be adjusted, while running, by varying the tension of the external spring B. When the ball radius increases due to the speed rising the bell crank levers move the sleeve C to the right and partially close the inlet valve through the lever D and valve rod A. In a well-designed governor of this type the sleeve C must be as light

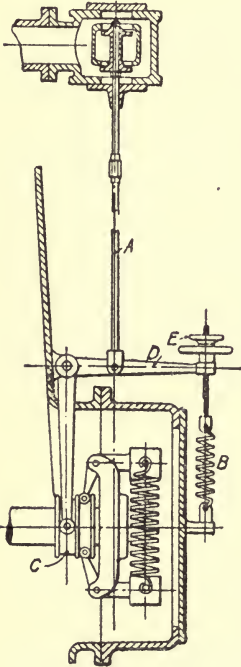

FIG. 237.

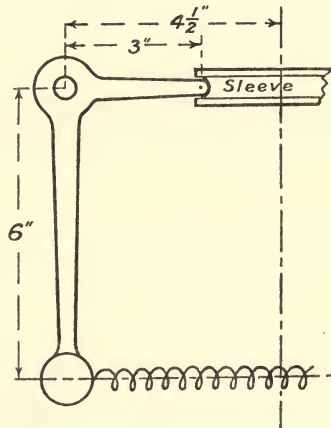

FIG. 238.

as possible, otherwise its inertia may cause hunting. The theory of this governor is very similar to that of the Hartnell previously given and will be best understood by studying the following numerical example.

EXAMPLE.—A spring loaded governor of the type shown in Fig. 237 is fitted with a spring which extends one inch for a pull of 30 pounds. The dimensions of the bell crank lever carrying the balls are shown in

Fig. 238, the fulcrum being at point F. The weight of each ball is 5 pounds, and there is no tension on the spring when the balls are at a radius of 3 inches. Neglecting the controlling effect of the balls and arms, find the speed at which the governor will run when the balls are at a radius of 5 inches, and find also the force exerted on the sleeve if, when the balls are in that position, the speed increases 10 per cent.

When the balls are at a radius of 5 inches the spring is stretched $10 - 6 = 4$ inches. The controlling force on the balls will therefore be $4 \times 30 = 120$ pounds.

$$\therefore \frac{5}{32.2} \times \omega^2 \times \frac{5}{12} = 120$$

$$\omega = 43.2 \text{ radians per second,}$$

$$\text{or } n = 413 \text{ revolutions per minute.}$$

If the radius remains unaltered but the speed increases 10 per cent. the controlling force will increase to

$$120 \times (1.1)^2 = 145.2 \text{ pounds,}$$

i.e. an increase of 25.2 pounds per ball.

Taking moments about F (Fig. 238) we have

$$\text{Force on sleeve} = 25.2 \times 2 \times \frac{6}{3} = 100.8 \text{ pounds.}$$

The Hartung Governor.—In the governors previously described the levers which transmit the movement of the balls to the sleeve also transmit the controlling force to the balls with the attendant frictional resistance which may be excessive in amount. One of the great advantages of the Hartung governor, other than its compactness, is that the levers merely transmit the motion, as will be evident from an inspection of Fig. 239. An outward movement of the weights A is resisted by the internal springs and the movement only is transmitted to the sleeve D by the levers C. The friction of the governor is therefore very small, and it may be made as powerful and as sensitive as desired.

The Proell Governor.—This governor is shown in Fig. 240, a general statical theory being as follows:—

Let w be the weight of each ball, W the total load on the sleeve due to the compressed spring and F the controlling force on each ball. The outward horizontal force P on the end of the bell crank lever may be first found by taking moments about point C (Fig. 241) which gives

$$P = F \times \frac{a+b}{b} \dots \dots \dots (1)$$

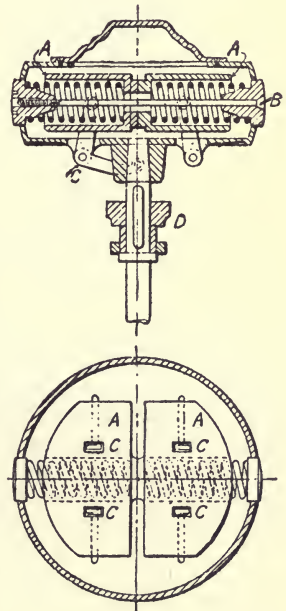

FIG. 239.

$$= \frac{w}{g} \omega^2 r \times \left(\frac{a+b}{b} \right) \dots \dots \dots (1A)$$

Then taking moments about the pin A we have

$$\frac{W}{2} \times x = P \times y \dots \dots \dots (2)$$

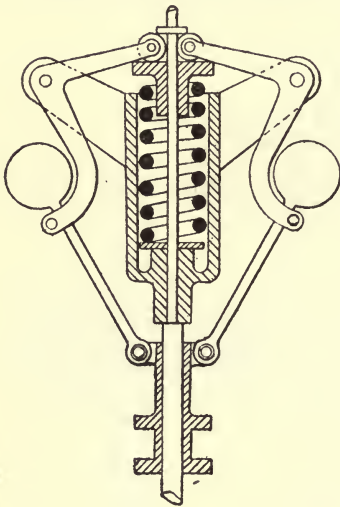

FIG. 240.

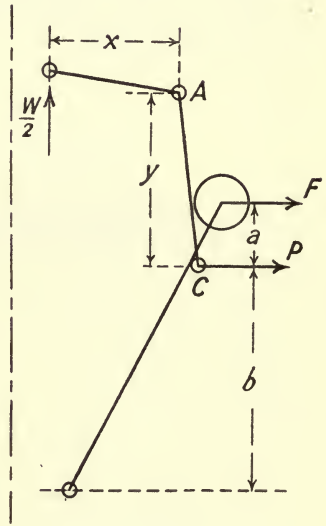

FIG. 241.

258. Curves of Controlling Force.—It has been shown analytically in Art. 254 that the effect of friction is to increase the range of speed of the governor, and therefore to decrease its sensitiveness. The effect may also be very conveniently shown graphically, as first suggested by Mr. Hartnell,¹ by drawing a curve having the controlling force as ordinates, and the radius of the ball circle as abscissæ. Such a curve for a Porter governor is shown in Fig. 242 at *ab*, in which, neglecting friction, the controlling force is given by

$$F = \frac{W + w}{W} \cdot \frac{r}{h} \quad (5), \text{ Art. 254.}$$

If now any convenient radius be chosen, such as *on*, and a perpendicular drawn, the distance *nx* may be set off equal to the centrifugal force $\frac{W}{g} \omega^2 r$, or $0.00034wrn^2$, where $r = on$, to the same scale as that of the controlling force. The point *e*, at which the line *ox* cuts the curve of controlling force, will give the radius *r* at which the balls will rotate at this speed. Vertical distances measured from *n* along the ordinate *nx* are evidently proportional to the square of the speed, *i.e.* to ω^2 or n^2 , and may

¹ *Proc. I. Mech. E.*, 1882.

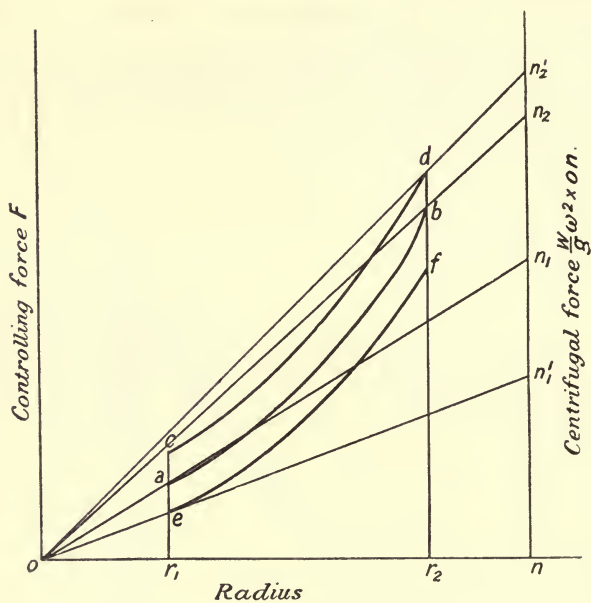

FIG. 243.

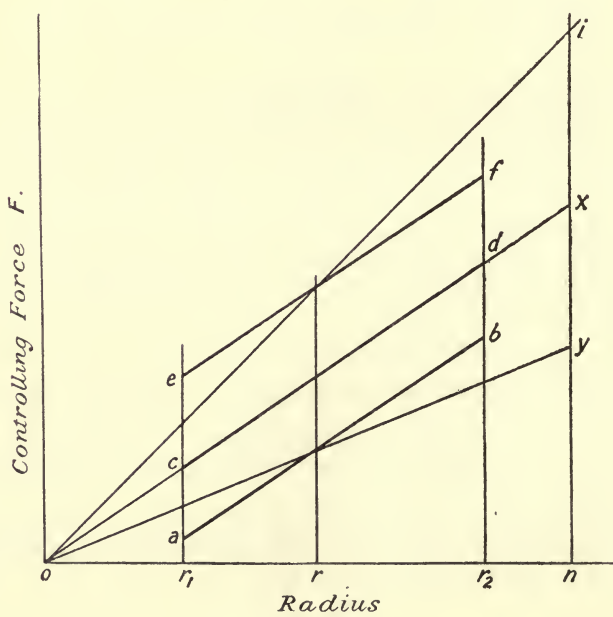

FIG. 244.

As the radius decreases fe represents the controlling force, whilst ab represents the force, neglecting friction, as in Fig. 242. The power absorbed in friction is represented by the area $cdfe$, and the range of speed is increased from $n_1 n_2^2$ to $n_1' n_2'$.

Spring Controlled Governors.—The foregoing remarks apply, but now the curve becomes a straight line, since the force exerted by the spring is proportional to its deflection, and therefore to the radius of the ball circle. By varying the initial tension of the spring three conditions may be obtained, namely:—

- (1) Stability as shown by ab (Fig. 244), since $\frac{dE}{dr} > \frac{F}{r}$.
- (2) Isochronism given by cd , since $\frac{dF}{dr} = \frac{F}{r}$.
- (3) Instability given by ef , since $\frac{dF}{dr} < \frac{F}{r}$.

At any radius r , y gives the equilibrium speed of the stable governor from ab , and x gives the speed of isochronism.

EXAMPLES XXI

- 1. In a simple unloaded Watt governor estimate the change in height when the speed increases from 100 to 120 revolutions per minute.
- 2. Prove that the height, in feet, of a loaded governor of the Porter type with equal arms and links is given by

$$h = \frac{W + w}{w} \times \frac{0.816}{n^2}$$

where n is the speed in revolutions per second. If $w = 4$ pounds, $W = 56$ pounds, and the speed suddenly increases from 250 to 255 revolutions per minute, what will be the lifting force at the sleeve, neglecting friction? (L.U.)

3. The balls of a Porter governor weigh 5 pounds each, and the central load weighs 95 pounds. Calculate the height to which the balls will rise when running at 240 revolutions per minute, if the resistance at the sleeve due to moving the governor gear is 5 pounds. How much must the speed decrease to before the balls begin to descend, and what must be the ratio between the two extreme speeds which will not cause any change of position of the governor balls?

4. The governor of a steam engine is of the Porter type, and runs at 180 revolutions per minute. If the height of the governor when running at its normal speed is 7.5 inches, what is the ratio between the load and the weight of one of the balls? What would be the proportional increase of speed for this governor before it could come into operation, if the frictional resistance be assumed equal to 0.1 of the load acting on the sleeve? (L.U.)

5. In a spring-controlled governor, the curve of controlling force is a straight line; when the balls are 14 inches apart the controlling force is 240 pounds, and when 8 inches apart 120 pounds. At what speed will the governor run when the balls are 10 inches

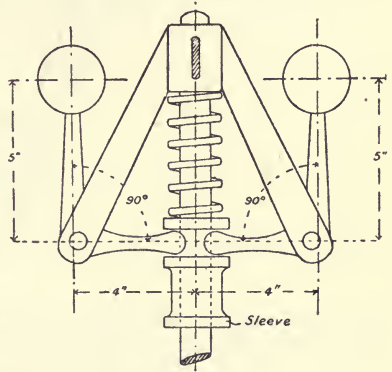

FIG. 245.

apart? What initial tension would be required on the spring for isochronism, and what would then be the speed? Each ball weighs 20 pounds. (L.U.)

6. A spring-controlled governor of the type shown in Fig. 245 is provided with balls each weighing 3 pounds. Neglecting the effect of the obliquity of the arms of the bell-cranks and the mass of the bell-crank levers, find the force exerted on the sleeve when the governor is running at 300 revolutions per minute. Find the strength of the spring, so that the governor will revolve steadily in the position shown in Fig. 245, and also in a position determined by a vertical movement of the sleeve of 0.2 inch when the speed increases 5 per cent.

7. Show that a simple Watt governor may be made nearly isochronous by crossing the arms. Draw for radii between 6 and 8 inches the controlling force curve of such a governor with crossed arms, each arm being 12 inches long, and pivoted at a point 1.5 inches from the axis, and each ball weighing 10 pounds. Find from the curve the "power" of the governor, expressing it in foot-pounds. (L.U.)

8. Show for a loaded governor of the Porter type that when the central load rises and falls twice as fast as the balls

$$s = \sqrt{I + \lambda} - \sqrt{I - \lambda}$$

where s = the difference between the highest and lowest speeds in any position due to friction, divided by the mean speed in that position.

λ = equivalent frictional resistance at the sleeve divided by the weight of a ball plus the load. (L.U.)

9. Find, for the position shown in Fig. 246, the speed at which the governor runs,

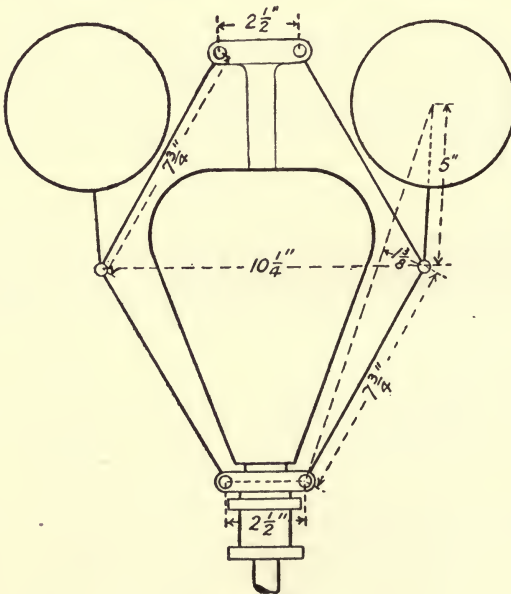

FIG. 246.

neglecting friction and the weight of the arms. Explain why the governor is more sensitive than if the balls were placed at the junction of the links. The weight of each ball is 20 pounds, and of the load 80 pounds. (L.U.)

10. In a loaded governor of the Porter type, with equal links 12 inches long, pivoted at the axis, the weight of each ball is 10 pounds, and of the load 60 pounds. When the ball radius is 7 inches, find the speed of revolution, allowing for the effect of the load and the centrifugal action of the links, which may be taken as of uniform section, and of weight 4 pounds each. (L.U.)

ANSWERS TO EXAMPLES

EXAMPLES I.

- (1) 8.47 cubic feet.
 (2) 524° F. ; 26170 foot-pounds ; 116.85 B.Th.U.
 (3) 1824 foot-pounds.
 (4) 12,440 foot-pounds.
 (5) 15,255 foot-pounds.
 (6) (a) 139.9 pounds per square inch ; (b) 23,900 foot-pounds.
 (7) (a) 3540° F. ; Heat expended = 39,600 foot-pounds ; work done = 10,800 foot-pounds ; (b) 1728° F. ; work done = loss of internal energy = 26,093 foot-pounds.
 (8) 347° F. ; 2913° F.
 (9) 56.54 pounds per square inch ; 634° F.
 (10) 667° F. ; 126,170 foot-pounds.
 (11) (a) 104 cubic feet ; 778,500 foot-pounds ; (b) 57.4 cubic feet ; 419,400 foot-pounds.
 (12) -0.54 \dot{p} ; +0.32 \dot{p} ; -150 B.Th.U. per second.
 (13) (a) 6600 foot-pounds ; (b) 4750 foot-pounds ; (c) 495° F.
 (14) 27.7 pounds per square inch ; 85.23 B.Th.U. ; 0.0947 ranks.
 (15) 2704 pounds per square foot ; 39720 foot-pounds ; 51.05 B.Th.U. ; 0.0947 ranks.
 (16) 0.0348 ranks.

EXAMPLES II.

- (1) (a) 0.534 ; (b) 0.449.
 (2) (a) 0.562 ; (b) 0.172.
 (3) 0.588 ; 9.2.
 (4) 0.355.
 (5) 0.184.
 (6) 28.54 pounds per square inch.
 (7) 86.0 pounds per square inch ; 0.581.
 (8) 0.553.

EXAMPLES III.

- (1) 4.33 cubic feet.
 (2) (a) H = 1191 B.Th.U. ; I = 1107.7 B.Th.U. ; (b) H = 933.2 B.Th.U. ; I = 874.9 B.Th.U.
 (3)

A.	B.	C.	
(a) 10.98	10.45	10.48	} pounds } per cent.
(b) 75.81	72.17	72.32	

- (4) 63 per cent.
- (5) 0·420 pound ; 0·900.
- (6) 0·987.
- (7) 0·467.
- (8) 0·968.
- (9) 0·920
- (10) 0·987.
- (11) 1·693 ranks.
- (12) (a) 0·860 ; (b) 0·688 ; (c) 0·912 ; (d) 23 pounds per square inch absolute.
- (13) 90 pounds per square inch absolute.
- (14) Temperature = 414° F., superheat 201° F. ; gain of entropy 0·276 units.
- (15) Before expansion, temperature = 588° F., superheat = 260° F. After expansion, temperature = 286° F., superheat = 46° F.
- (16) 0·237 units.
- (17) Temperature = 247·9° F., superheat = 42° F. ; 0·2952 units.
- (18) Temperature = 298·1° F., superheat = 92·2° F. ; 0·30 units.
- (20) 0·2175 pound ; 0·0355 pound.

EXAMPLES IV.

- (1) (a) 108·5 B.Th.U. ; (b) 98·3 B.Th.U.
- (2) Dryness fraction 0·666 ; $n = 1·10$.
- (3) (a) 79·02 B.Th.U. ; 7·5 per cent. ; (b) 63·15 B.Th.U., 7·1 per cent.
- (4) 255·3 B.Th.U. ; 23·6 per cent.
- (5) 221·5 B.Th.U. ; 23·3 per cent.
- (6) (a) 0·483 ; (b) 0·428.
- (7) 17·63 pounds.
- (8) 9·92 pounds, 0·874.
- (9) 596° F. ; 26·2 per cent. ; 357·48 B.Th.U.
- (10) Stirling 49·0 per cent., steam 16·9 per cent. ; $\frac{\text{diameter of Stirling}}{\text{diameter of steam}} = \frac{1·03}{1}$
- (11) 300·9 B.Th.U. ; 0·272.
- (12) (a) 8·82 pounds ; (b) 7·77 pounds.
- (13) 27·6 per cent. ; without feed heating 26·4 per cent.
- (14) 26·8 per cent.
- (15) (a) 31·3 per cent. ; (b) 29·3 per cent.
- (16) (a) 13·50 per cent. ; (b) 13·74 per cent.
- (17) 80·65 pounds per square inch ; 85·1.
- (18) 8·12 inches.
- (19) 2·60.
- (20) (a) 26·4 per cent. ; (b) 31·2 per cent.

EXAMPLES V.

- (1) (a) 19,967 foot-pounds ; (b) 18,000 foot-pounds ; (c) 13,955 foot-pounds ; (d) 19,967 foot-pounds.
- (2) (b) 0·807, 5310 ; (b) 0·804 ; 5400 ; (c) 0·826, 4770.
- (3) 0·841 ; 0·887.
- (4) 12.

EXAMPLES VI.

- (1) 5 ; 15 pounds per square inch absolute ; $\frac{8}{15}$; $\frac{\text{H.P.}}{\text{L.P.}} = \frac{1}{1·04}$.
- (2) 3·702 ; 18·58 pounds per square inch absolute ; 0·480 ; $\frac{\text{H.P.}}{\text{L.P.}} = \frac{1}{1·09}$.
- (3) L.P. = 31·42 inches, H.P. = 16·8 inches ; 0·428 stroke ; $\frac{\text{H.P.}}{\text{L.P.}} = \frac{1}{1·229}$.

- (4) $\frac{\text{H.P.}}{\text{L.P.}} = \frac{1}{1.72}$.
 (5) 31.6 inches, 54.6 inches, 86.5 inches, stroke 4 feet.
 (6) 64.33 pounds per square inch ; 19.09 pounds per square inch.

EXAMPLES VII.

- (1) 123.3.
 (2) -131.7° F. ; 1.712 ; 30.6 pounds.
 (3) 5.90.
 (4) (a) 5.74 ; (b) 5.66.
 (5) (a) 6.33 ; (b) 6.33.
 (6) (a) 5.38 ; (b) 6.26.
 (7) 44.24.
 (8) Liquid $\phi = 0.003312t^{\circ}$; vapour $\phi = 1.158 - 0.003456t^{\circ}$; 6.14 ; 65.1 pounds.

EXAMPLES VIII.

- (1) 1260 feet per second ; 0.951.
 (2) Area of throat 0.329 square inch, $x = 0.96$; area of discharge end 3.069 square inches, $x = 0.802$.
 (3) Area of throat 0.367 square inch, of discharge end 1.066 square inch. Condition of steam, in throat superheat = 24° F., at discharge end $x = 0.90$.
 (4) 5.56 pounds ; steam orifice 1.134 square inches ; discharge orifice 0.0404 square inch ; feed temperature 200° F.

EXAMPLES IX.

- (1) 29.5° ; 162,660 foot-pounds ; 1575 feet per second ; 0.808.
 (2) 36° (nearly) ; 177,690 foot-pounds ; 1690 feet per second ; 0.883.
 (3) 28.8° ; 0.789 ; 159.3 H.P.
 (4) 29.5° ; 154,540 foot-pounds ; 1345 feet per second ; 0.860.
 (5) Moving blades, inlet angle = exit angle = 24.5° . Stationary blades, 1st set, inlet angle = 34° , exit angle = 17.3° ; 2nd set, inlet angle = 43° , exit angle = 7° .
 (6) 116.1 H.P.

EXAMPLES X.

- (1) 49.2 per cent.
 (2) 63.6.
 (3) 48.3 pounds ; -113° F.
 (4) (a) 100,655 foot-pounds ; (b) 83,410 foot-pounds ; 29.9 C.H.U. ; (c) 78,050 foot-pounds, in 1st cooler 18.28 C.H.U., in 2nd cooler 18.28 C.H.U.
 (5) (a) 85,690 foot-pounds ; (b) 76,840 foot-pounds ; 15.9 C.H.U. ; (c) 74,166 foot-pounds in 1st and 2nd coolers 10.2 C.H.U.
 (6) 9.12 inches diameter, 2 feet 6 inches stroke.

EXAMPLES XI.

- (1) 11.04 pounds ; CO_2 14.06, H_2O 2.15, N_2 73.87, $\text{O}_2 = 9.92$ per cent.
 (2) 1.0424 cubic foot ; 10.6 per cent. ; CO_2 16.60, H_2O 10.21, N_2 73.19 per cent.
 (3) 0.2417 ; 2292 B.Th.U.
 (4) (a) 1519 B.Th.U. ; (b) 852 B.Th.U. ; (c) 723 B.Th.U.
 (5) (a) 17.5 per cent. ; 1502 B.Th.U. = 10.77 per cent. ; (b) 3214 B.Th.U.
 (6) (a) 1.28 pounds ; (b) 1039 C.H.U. ; (c) 943 C.H.U.
 (7) 93.5 feet.

- (8) (a) 5.39 B.H.P. ; (b) 3.148 B.H.P.
 (9) (a) 5.76 cubic feet; (b) 687.9; (c) 621.3.
 (10) 576.4; 524.7 B.Th.U. per cubic foot.
 (11) 10,943 calories per gram, or 19,697 B.Th.U. per pound.
 (12) 70 per cent. ; CO 34.71, N₂ 65.29 per cent. ; 119 B.Th.U. per cubic foot.
 (13) 3.846 cubic feet ; 1.86 cubic feet.

EXAMPLES XII.

- (2) (a) 7200 ; (b) 3064 ; (c) 6100.
 (3) On steam side 128.3° F., on water side 127.98° F.

EXAMPLES XIII.

- (1) 51 per cent. ; 488° C. ; 157.9 pounds per square inch absolute.
 (2) (a) 48 per cent. ; (b) 38.1 per cent.
 (3) (a) 0.0393 pound ; (b) 158 pounds per square inch absolute and 488° C. ;
 (c) 3616° ; (d) 907 pounds per square inch absolute ; (e) 1948° C. and 77.4
 pounds per square inch absolute ; (f) 51 per cent.
 (4) $p v^{1.323} = 200.2$.
 (5) At A, 1880° F. ; at B, 1060° F. ; Heat taken from the gas 1271 foot-
 pounds, or 1.63 B.Th.U.

EXAMPLES XVI.

- (1) (a) I.H.P. = 50.9, B.H.P. = 20.45 ; (b) 0.37 pound, 0.63 pound ; (c) 2158
 B.Th.U. ; (d) 1365 B.Th.U. ; (e) 1917 B.Th.U.
 (2) (a) 21,200 B.Th.U. ; (b) 63,020 B.Th.U. ; (c) 35,960 B.Th.U. ; (d) 2220
 B.Th.U.
 (4) (a) 39.0 ; (b) 30.76 ; (c) 78.8 per cent. ; (d) 30.0 per cent. ; (e) 23.64
 per cent. ; (f) 0.58.
 (5) (a) 28.6 per cent. ; (b) by steam 970 B.Th.U., by dry air 1501 B.Th.U.
 total = 2471 B.Th.U. ; (c) 99 B.Th.U.
 (6)

	C.H.U.	Per cent.
Heat in 1 pound of oil	10,720	100.00
Heat converted into work (Thermal efficiency)	4242	39.57
Heat rejected to cooling water	2309	21.54
Heat rejected to exhaust	2743	25.58
Unaccounted for	1426	13.31
Total	10,720	100.00

EXAMPLES XVII.

- (1) 1858.5.
 (2) 7310 pounds ; I.H.P. = 974.
 (3) 171.6 revs. per min. ; I.H.P. = 130.9, W = 1906 pounds.

(4)

	B.Th.U.	Per cent.
Gross heat supply entering engine per minute	37,480	100'00
Heat equivalent of I.H.P.	4,665	12'44
Heat leaving engine in jacket drain	1,037	2'76
Heat leaving engine in exhaust steam	29,812	79'54
Unaccounted for	1,966	5'26
Total	37,480	100'00

Thermal efficiency = 13'52 per cent.

(5)

	B.Th.U.	Per cent.
Gross heat supply entering engine per minute	148,880	100 00
Heat equivalent of I.H.P.	20,962	14'07
Heat leaving engine in jacket drain	5,760	3'87
Heat leaving engine in exhaust steam.	93,838	63'03
Unaccounted for.	28,320	19'03
Total	148,880	100'00

(a) 15'16 pounds ; (b) 15'19 per cent. ; (c) 163 B.Th.U. ; (d) 0'584.

(6) 17'5 pounds.

(7) 71'0 per cent. ; (1) 9'52 pounds, (2) 9'93.

(8)

	B.Th.U.	Per cent.
Total heat value of 1 pound of dried fuel	14,000	100'00
Heat transferred to water (Thermal efficiency)	9,955	71'11
Heat carried away by products of combustion	1,603	11'46
Heat carried away by excess air	860	6'24
Heat lost in evaporating and superheating } moisture in the fuel }	25	0'02
Heat lost by incomplete combustion	749	5'45
Heat lost by unburnt carbon in ashes	32	0'03
Unaccounted for	776	5'69
Total	14,000	100'00

EXAMPLES XVIII.

(1) (a)

	Head end.	Crank end.
(a) { Outside lap	1'36"	0'85"
{ Inside lap	0'43"	0'72"
(b) Angle of advance $40\frac{1}{2}^\circ$		
(c) Maximum opening to steam	1'14"	1'65"
(d) Lead	0'25"	0'76"

(2) 41° ; 5'16 inches; 1'58 inch.

(3)

If data refers to	Crank end.	Head end.
Axle of advance	37'5°	45'5°
Travel	4'45"	6'16"
Outside lap	1'22"	2'10"

(4) (a) { Outside lap, crank end = 1'29", head end = 1'29".
 { Inside lap, crank end = 0'81", head end = 0'65".

(b) 0'477 stroke; (c) 45° .

(5) At head end 1'59 inch, at crank end 1'31 inch.

(6)

	Lead.	Cut-off.	Release.	Compression.	Max. opening to steam.	Max. opening to exhaust.	Outside lap.	Inside lap.
Head end .	0'25	0'64	0'898	0'805	0'72	1'5	0'86	0'08
Crank end .	0'50	0'64	0'85	0'855	0'94	1'5	0'64	0'08

Travel = 3'16 inches, angle of advance 46° .

(7) 1'75 inches; 150° ; 0'686 inch.

(8) and (9)

VALUES OF "δ" INCHES.

Cut-off.	Head end.	Crank end.	Difference.
0'2	-0'53	-0'85	0'33
0'3	-0'87	-1'21	0'33
0'4	-1'13	-1'45	0'31
0'5	-1'40	-1'60	0'20
0'6	-1'59	-1'70	0'11

(10) (a) travel = 5'55 inches, angle of advance $36^\circ 5'$, outside lap 1'42 inches.

(b)

CUT-OFF AT

	0'1	0'2	0'3	0'4	0'5	0'6
Head end a =	0'04"	0'72"	1'20"	1'65"	2'02"	2'33'

(c) 4'35 inches.

- (11) (a) 3 inches, angle of advance 20° ; (b) 16 inches, angle of advance 90° .
 (12) $r = 2.83$ inches; $\phi = 102^\circ - 36'$.
 (13) (a) 8.4 inches; (b) 43° .
 (14) $r = 2.1$ inches, angle of advance = 45° .
 (15) (a) 1 foot 5 inches; (b) 9 inches; (c) $3''$, 20° .

EXAMPLES XIX.

- (1) (a) 21,910 pound-feet; (b) 21,400 pound-feet.
 (2) 225 foot-pounds; -199.5 pound-feet; -221 pound-feet.
 (3) $50,840 \frac{\sin \theta \cos \theta}{(36 - \sin^2 \theta)^2}$.
 (4) 33.86 and 21.90 pounds per square inch.
 (5) 49,490 pound-feet units.
 (6) $l = 4776$ pound-feet units, rim speed 78.68 feet per second.
 (7) 11,890 pound-feet units.

EXAMPLES XX.

- (1) On left hand wheel 200 pounds; on right hand wheel 100 pounds.
 (2) 46.1 pounds; 9.39 pounds, 301.6° from the 2 pound radius.
 (3) Plane A, 98.6 pounds at 269.5° to the 2 pound radius; Plane B, 131.8 pounds at 347.5° to the 200 pound radius.
 (4) 4th mass = 1.72 tons; Reckoning from the left, angle between $1\frac{1}{2}$ and 2 = 146.5° , between $1\frac{1}{2}$ and $2\frac{1}{2}$ = 242° , between $1\frac{1}{2}$ and 1.72 = 40° .
 (5) Crank D, mass = 2.88 tons, angle from A = 277° ; Crank E, mass = 2.72 tons, angle from A = 58° .
 (6) R.H. wheel, 238 pounds, 155° behind R.H. crank; L.H. wheel, 238 pounds 155° leading L.H. crank.
 (7) With right crank leading, R.H. wheel, 409 pounds, 184.8° leading R.H. crank; L.H. wheel, 409 pounds, 184.8° behind L.H. crank; 3560 pounds.
 (8) 76.43 tons-feet; 21.84 tons-feet.

EXAMPLES XXI.

- (1) 1.074 inch.
 (2) 2.4 pounds.
 (3) 12.84 inches; 228.2 revs. per min.; 1.051.
 (4) 5.9; 4 per cent.
 (5) 237 revs. per min.; 40 pounds when $r = 4''$; 265 revs. per min.
 (6) 76.62 pounds; 65.6 pounds per inch of compression.
 (9) 350 revs. per min.
 (10) 162 revs. per min.

PROPERTIES OF SATURATED STEAM

SATURATED STEAM: PRESSURE TABLE. (Marks and Davis.)

Pressure, lbs. sq. in. abs.	Tempera- ture, ° F.	Sp. vol., cub. ft. per lb.	Heat of the liquid, B.Th.U.	Latent heat of evap., B.Th.U.	Total heat of steam, B.Th.U.	Entropy.		
						Water.	Evap.	Steam.
1	101·83	333·0	69·8	1034·6	1104·4	0·1327	1·8427	1·9754
2	126·15	173·5	94·0	1021·0	1115·0	0·1749	1·7431	1·9180
4	153·01	90·5	120·9	1005·7	1126·5	0·2198	1·6416	1·8614
6	170·06	61·89	137·9	995·8	1133·7	0·2471	1·5814	1·8285
8	182·86	47·27	150·8	988·2	1139·0	0·2673	1·5380	1·8053
10	193·22	38·38	161·1	982·0	1143·1	0·2832	1·5042	1·7874
12	201·96	32·36	169·9	976·6	1146·5	0·2967	1·4760	1·7727
14	209·55	28·02	177·5	971·9	1149·4	0·3081	1·4523	1·7604
16	216·3	24·79	184·4	967·6	1152·0	0·3183	1·4311	1·7549
18	222·4	22·16	190·5	963·7	1154·2	0·3273	1·4127	1·7400
20	228·0	20·08	196·1	960·0	1156·2	0·3355	1·3965	1·7320
22	233·1	18·37	201·3	956·7	1158·0	0·3430	1·3811	1·7241
24	237·8	16·93	206·1	953·5	1159·6	0·3499	1·3670	1·7169
26	242·2	15·72	210·6	950·6	1161·2	0·3564	1·3542	1·7106
28	246·4	14·67	214·8	947·8	1162·6	0·3623	1·3425	1·7048
30	250·3	13·74	218·8	945·1	1163·9	0·3680	1·3311	1·6991
32	254·1	12·93	222·6	942·5	1165·1	0·3733	1·3205	1·6938
34	257·6	12·22	226·2	940·1	1166·3	0·3784	1·3107	1·6891
36	261·0	11·58	229·6	937·7	1167·3	0·3832	1·3014	1·6846
38	264·2	11·01	232·9	935·5	1168·4	0·3877	1·2925	1·6802
40	267·3	10·49	236·1	933·3	1169·4	0·3920	1·2841	1·6761
42	270·2	10·02	239·1	931·2	1170·3	0·3962	1·2759	1·6721
44	273·1	9·59	242·0	929·2	1171·2	0·4002	1·2681	1·6683
46	275·8	9·20	244·8	927·2	1172·0	0·4040	1·2607	1·6647
48	278·5	8·84	247·5	925·3	1172·8	0·4077	1·2536	1·6613
50	281·0	8·51	250·1	923·5	1173·6	0·4113	1·2468	1·6581
52	283·5	8·20	252·6	921·7	1174·3	0·4147	1·2402	1·6549
54	285·9	7·91	255·1	919·9	1175·0	0·4180	1·2339	1·6519
56	288·2	7·65	257·5	918·2	1175·7	0·4212	1·2278	1·6490
58	290·5	7·40	259·8	916·5	1176·4	0·4242	1·2218	1·6460
60	292·7	7·17	262·1	914·9	1177·0	0·4272	1·2160	1·6432
62	294·9	6·95	264·3	913·3	1177·6	0·4302	1·2104	1·6406
64	297·0	6·75	266·4	911·8	1178·2	0·4330	1·2050	1·6380
66	299·0	6·56	268·5	910·2	1178·8	0·4358	1·2007	1·6355
68	301·0	6·38	270·6	908·7	1179·3	0·4385	1·1946	1·6331
70	302·9	6·20	272·6	907·2	1179·8	0·4410	1·1896	1·6307
72	304·8	6·04	274·5	905·8	1180·4	0·4437	1·1848	1·6285
74	306·7	5·89	276·5	904·4	1180·9	0·4462	1·1801	1·6263
76	308·5	5·74	278·3	903·0	1181·4	0·4487	1·1755	1·6242
78	310·3	5·60	280·2	901·7	1181·8	0·4511	1·1710	1·6221
80	312·0	5·47	282·0	900·3	1182·3	0·4535	1·1665	1·6200

PROPERTIES OF SATURATED STEAM

Pressure, lbs. sq. in. abs.	Tempera- ture, ° F.	Sp. vol., cub. ft. per lb.	Heat of the liquid, B.Th.U.	Latent heat of evap., B.Th.U.	Total heat of steam, B.Th.U.	Entropy.		
						Water.	Evap.	Steam.
82	313.8	5.34	283.8	899.0	1182.8	0.4557	1.1623	1.6180
84	315.4	5.22	285.5	897.7	1183.2	0.4579	1.1581	1.6160
86	317.1	5.10	287.2	896.4	1183.6	0.4601	1.1540	1.6141
88	318.7	5.00	288.9	895.2	1184.0	0.4623	1.1500	1.6123
90	320.3	4.89	290.5	893.9	1184.4	0.4644	1.1461	1.6105
92	321.8	4.79	292.1	892.7	1184.8	0.4664	1.1423	1.6087
94	323.4	4.69	293.7	891.5	1185.2	0.4684	1.1385	1.6069
96	324.9	4.60	295.3	890.3	1185.6	0.4704	1.1348	1.6052
98	326.4	4.51	296.8	889.2	1186.0	0.4724	1.1312	1.6036
100	327.8	4.429	298.3	888.0	1186.3	0.4743	1.1277	1.6020
105	331.4	4.230	302.0	885.2	1187.2	0.4789	1.1191	1.5980
110	334.8	4.047	305.5	882.5	1188.0	0.4834	1.1108	1.5942
115	338.1	3.880	309.0	879.8	1188.8	0.4877	1.1030	1.5907
120	341.3	3.726	312.3	877.2	1189.6	0.4919	1.0954	1.5873
125	344.4	3.583	315.5	874.7	1190.3	0.4959	1.0880	1.5839
130	347.4	3.452	318.6	872.3	1191.0	0.4998	1.0809	1.5807
135	350.3	3.331	321.7	869.9	1191.6	0.5035	1.0742	1.5777
140	353.1	3.219	324.6	867.6	1192.2	0.5072	1.0675	1.5747
145	355.8	3.112	327.4	865.4	1192.8	0.5107	1.0612	1.5719
150	358.5	3.012	330.2	863.2	1193.4	0.5142	1.0550	1.5692
155	361.0	2.920	332.9	861.0	1194.0	0.5175	1.0489	1.5664
160	363.6	2.834	335.6	858.8	1194.5	0.5208	1.0431	1.5639
165	366.0	2.753	338.2	856.8	1195.0	0.5239	1.0376	1.5615
170	368.5	2.675	340.7	854.7	1195.4	0.5269	1.0321	1.5590
175	370.8	2.602	343.2	852.7	1195.9	0.5299	1.0268	1.5567
180	373.1	2.533	345.6	850.8	1196.4	0.5328	1.0215	1.5543
185	375.4	2.468	348.0	848.8	1196.8	0.5356	1.0164	1.5520
190	377.6	2.406	350.4	846.9	1197.3	0.5384	1.0114	1.5498
195	379.8	2.346	352.7	845.0	1197.7	0.5410	1.0066	1.5476
200	381.9	2.290	354.9	843.2	1198.1	0.5437	1.0019	1.5456
210	386.0	2.187	359.2	839.6	1198.8	0.5488	0.9928	1.5416
220	389.9	2.091	363.4	836.2	1199.6	0.5538	0.9841	1.5379
230	393.8	2.004	367.5	832.8	1200.2	0.5586	0.9758	1.5344
240	397.4	1.924	371.4	829.5	1200.9	0.5633	0.9676	1.5309
250	401.1	1.850	375.2	826.3	1201.5	0.5676	0.9600	1.5276
260	404.5	1.782	378.9	823.1	1202.1	0.5719	0.9525	1.5244
270	407.9	1.718	382.5	820.1	1202.6	0.5760	0.9454	1.5214
280	411.2	1.658	386.0	817.1	1203.1	0.5800	0.9385	1.5185
290	414.4	1.602	389.4	814.2	1203.6	0.5840	0.9316	1.5156
300	417.5	1.551	392.7	811.3	1204.1	0.5878	0.9251	1.5129
310	420.5	1.502	395.9	808.5	1204.5	0.5915	0.9187	1.5102
320	423.4	1.456	399.1	805.8	1204.9	0.5951	0.9125	1.5076
330	426.3	1.413	402.2	803.1	1205.3	0.5986	0.9065	1.5051
340	429.1	1.372	405.3	800.4	1205.7	0.6020	0.9006	1.5026
350	431.9	1.334	408.2	797.8	1206.1	0.6053	0.8949	1.5002
360	434.6	1.298	411.2	795.3	1206.5	0.6085	0.8894	1.4979
370	437.2	1.264	414.0	792.8	1206.8	0.6116	0.8840	1.4956
380	439.8	1.231	416.8	790.3	1207.1	0.6147	0.8788	1.4935
390	442.3	1.200	419.5	787.9	1207.4	0.6178	0.8737	1.4915
400	444.8	1.17	422.0	786.0	1208.0	0.621	0.868	1.489

THE THEORY OF HEAT ENGINES

GLAISHER'S FACTORS FOR WET AND DRY BULB HYGROMETER.
(From Ganot's "Physics.")

Dry bulb, temperature, °F.	Factor.	Dry bulb, temperature, °F.	Factor.
Below 24°	8.5	34° to 35°	2.8
24° to 25	6.9	35 " 40	2.5
25 " 26	6.5	40 " 45	2.2
26 " 27	6.1	45 " 50	2.1
27 " 28	5.6	50 " 55	2.0
28 " 29	5.1	55 " 60	1.9
29 " 30	4.6	60 " 65	1.8
30 " 31	4.1	65 " 70	1.8
31 " 32	3.7	70 " 75	1.7
32 " 33	3.3	75 " 80	1.7
33 " 34	3.0	80 " 85	1.6

Angle.		Chord.	Sine.	Tangent.	Co-tangent.	Cosine.			
De-grees.	Radians.								
0°	0	000	0	0	∞	1	1.414	1.5708	90°
1	.0175	.017	.0175	.0175	57.2900	.9998	1.402	1.5533	89
2	.0349	.035	.0349	.0349	28.6363	.9994	1.389	1.5359	88
3	.0524	.052	.0523	.0524	19.0811	.9986	1.377	1.5184	87
4	.0698	.070	.0698	.0699	14.3007	.9976	1.364	1.5010	86
5	.0873	.087	.0872	.0875	11.4301	.9962	1.351	1.4835	85
6	.1047	.105	.1045	.1051	9.5144	.9945	1.338	1.4661	84
7	.1222	.122	.1219	.1228	8.1443	.9925	1.325	1.4486	83
8	.1396	.140	.1392	.1405	7.1154	.9903	1.312	1.4312	82
9	.1571	.157	.1564	.1584	6.3138	.9877	1.299	1.4137	81
10	.1745	.174	.1736	.1763	5.6713	.9848	1.286	1.3963	80
11	.1920	.192	.1908	.1944	5.1446	.9816	1.272	1.3788	79
12	.2094	.209	.2079	.2126	4.7046	.9781	1.259	1.3614	78
13	.2269	.226	.2250	.2309	4.3315	.9744	1.245	1.3439	77
14	.2443	.244	.2419	.2493	4.0108	.9703	1.231	1.3265	76
15	.2618	.261	.2588	.2679	3.7321	.9659	1.218	1.3090	75
16	.2793	.278	.2756	.2867	3.4874	.9613	1.204	1.2915	74
17	.2967	.296	.2924	.3057	3.2709	.9563	1.190	1.2741	73
18	.3142	.313	.3090	.3249	3.0777	.9511	1.176	1.2566	72
19	.3316	.330	.3256	.3443	2.9042	.9455	1.161	1.2392	71
20	.3491	.347	.3420	.3640	2.7475	.9397	1.147	1.2217	70
21	.3665	.364	.3584	.3839	2.6051	.9336	1.133	1.2043	69
22	.3840	.382	.3746	.4040	2.4751	.9272	1.118	1.1868	68
23	.4014	.399	.3907	.4245	2.3559	.9205	1.104	1.1694	67
24	.4189	.416	.4067	.4452	2.2460	.9135	1.089	1.1519	66
25	.4363	.433	.4228	.4663	2.1445	.9063	1.075	1.1345	65
26	.4538	.450	.4384	.4877	2.0503	.8988	1.060	1.1170	64
27	.4712	.467	.4540	.5095	1.9626	.8910	1.046	1.0996	63
28	.4887	.484	.4695	.5317	1.8807	.8829	1.030	1.0821	62
29	.5061	.501	.4848	.5543	1.8040	.8746	1.015	1.0647	61
30	.5236	.518	.5000	.5774	1.7321	.8660	1.000	1.0472	60
31	.5411	.534	.5150	.6009	1.6643	.8572	.985	1.0297	59
32	.5585	.551	.5299	.6249	1.6003	.8480	.970	1.0123	58
33	.5760	.568	.5446	.6494	1.5399	.8387	.954	.9948	57
34	.5934	.585	.5592	.6745	1.4826	.8290	.939	.9774	56
35	.6109	.601	.5736	.7002	1.4281	.8192	.923	.9599	55
36	.6283	.618	.5878	.7265	1.3764	.8090	.908	.9425	54
37	.6458	.635	.6018	.7536	1.3270	.7988	.892	.9250	53
38	.6632	.651	.6157	.7813	1.2799	.7880	.877	.9076	52
39	.6807	.668	.6293	.8098	1.2349	.7771	.861	.8901	51
40	.6981	.684	.6428	.8391	1.1918	.7660	.845	.8727	50
41	.7156	.700	.6561	.8693	1.1504	.7547	.829	.8552	49
42	.7330	.717	.6691	.9004	1.1106	.7431	.813	.8378	48
43	.7505	.733	.6820	.9325	1.0724	.7314	.797	.8203	47
44	.7679	.749	.6947	.9657	1.0355	.7193	.781	.8029	46
45°	.7854	.765	.7071	1.0000	1.0000	.7071	.765	.7854	45°
			Cosine.	Co-tangent.	Tangent.	Sine.	Chord.	Radians.	De-grees.
								Angle.	

	0	1	2	3	4	5	6	7	8	9	1234	5	6789
10	0000	0043	0086	0128	0170	0212	0253	0294	0334	0374	4 9 13 17 4 8 12 16	21 20	25 30 34 38 24 28 32 37
11	0414	0453	0492	0531	0569						4 8 12 15 4 7 11 15	19 19	23 27 31 35 22 26 30 33
12	0792	0828	0864	0899	0934	0607 0969	0645 1004	0682 1038	0719 1072	0755 1106	3 7 11 14 3 7 10 14	18 17	21 25 28 32 20 24 27 31
13	1139	1173	1206	1239	1271						3 7 10 13 3 7 10 12	16 16	20 23 26 30 19 22 25 29
14	1461	1492	1523	1553		1303	1335	1367	1399	1430	3 6 9 12 3 6 9 12	15 15	18 21 24 28 17 20 23 26
15	1761	1790	1818	1847	1875	1903					3 6 9 11 3 5 8 11	14 14	17 20 23 26 16 19 22 25
16	2041	2068	2095	2122	2148						3 5 8 11 3 5 8 10	14 13	16 19 22 24 15 18 21 23
17	2304	2330	2355	2380	2405	2175 2430	2201 2455	2227 2480	2253 2504	2279 2529	3 5 8 10 2 5 7 10	13 12	15 18 20 23 15 17 19 22
18	2553	2577	2601	2625	2648						2 5 7 9 2 5 7 9	12 11	14 16 19 21 14 16 18 21
19	2788	2810	2833	2856	2878	2672 2900	2695 2923	2718 2945	2742 2967	2765 2989	2 4 7 9 2 4 6 8	11 11	13 16 18 20 13 15 17 19
20	3010	3032	3054	3075	3096	3118	3139	3160	3181	3201	2 4 6 8	11	13 15 17 19
21	3222	3243	3263	3284	3304	3324	3345	3365	3385	3404	2 4 6 8	10	12 14 16 18
22	3424	3444	3464	3483	3502	3522	3541	3560	3579	3598	2 4 6 8	10	12 14 15 17
23	3617	3636	3655	3674	3692	3711	3729	3747	3766	3784	2 4 6 7	9	11 13 15 17
24	3802	3820	3838	3856	3874	3892	3909	3927	3945	3962	2 4 5 7	9	11 12 14 16
25	3979	3997	4014	4031	4048	4065	4082	4099	4116	4133	2 3 5 7	9	10 12 14 15
26	4150	4166	4183	4200	4216	4232	4249	4265	4281	4298	2 3 5 7	8	10 11 13 15
27	4314	4330	4346	4362	4378	4393	4409	4425	4440	4456	2 3 5 6	8	9 11 13 14
28	4472	4487	4502	4518	4533	4548	4564	4579	4594	4609	2 3 5 6	8	9 11 12 14
29	4624	4639	4654	4669	4683	4698	4713	4728	4742	4757	1 3 4 6	7	9 10 12 13
30	4771	4786	4800	4814	4829	4843	4857	4871	4886	4900	1 3 4 6	7	9 10 11 13
31	4914	4928	4942	4955	4969	4983	4997	5011	5024	5038	1 3 4 6	7	8 10 11 12
32	5051	5065	5079	5092	5105	5119	5132	5145	5159	5172	1 3 4 5	7	8 9 11 12
33	5185	5198	5211	5224	5237	5250	5263	5276	5289	5302	1 3 4 5	6	8 9 10 12
34	5315	5328	5340	5353	5366	5378	5391	5403	5416	5428	1 3 4 5	6	8 9 10 11
35	5441	5453	5465	5478	5490	5502	5514	5527	5539	5551	1 2 4 5	6	7 9 10 11
36	5563	5575	5587	5599	5611	5623	5635	5647	5658	5670	1 2 4 5	6	7 8 10 11
37	5682	5694	5705	5717	5729	5740	5752	5763	5775	5786	1 2 3 5	6	7 8 9 10
38	5795	5809	5821	5832	5843	5855	5866	5877	5888	5899	1 2 3 5	6	7 8 9 10
39	5911	5922	5933	5944	5955	5966	5977	5988	5999	6010	1 2 3 4	5	7 8 9 10
40	6021	6031	6042	6053	6064	6075	6085	6096	6107	6117	1 2 3 4	5	6 8 9 10
41	6128	6138	6149	6160	6170	6180	6191	6201	6212	6222	1 2 3 4	5	6 7 8 9
42	6232	6243	6253	6263	6274	6284	6294	6304	6314	6325	1 2 3 4	5	6 7 8 9
43	6335	6345	6355	6365	6375	6385	6395	6405	6415	6425	1 2 3 4	5	6 7 8 9
44	6435	6444	6454	6464	6474	6484	6493	6503	6513	6522	1 2 3 4	5	6 7 8 9
45	6532	6542	6551	6561	6571	6580	6590	6599	6609	6618	1 2 3 4	5	6 7 8 9
46	6628	6637	6646	6656	6665	6675	6684	6693	6702	6712	1 2 3 4	5	6 7 7 8
47	6721	6730	6739	6749	6758	6767	6776	6785	6794	6803	1 2 3 4	5	5 6 7 8
48	6812	6821	6830	6839	6848	6857	6866	6875	6884	6893	1 2 3 4	4	5 6 7 8
49	6902	6911	6920	6928	6937	6946	6955	6964	6972	6981	1 2 3 4	4	5 6 7 8
50	6990	6998	7007	7016	7024	7033	7042	7050	7059	7067	1 2 3 3	4	5 6 7 8

	0	1	2	3	4	5	6	7	8	9	1234	5	6789
51	7076	7084	7093	7101	7110	7118	7126	7135	7143	7152	1 2 3 3	4	5 6 7 8
52	7160	7168	7177	7185	7193	7202	7210	7218	7226	7235	1 2 2 3	4	5 6 7 7
53	7243	7251	7259	7267	7275	7284	7292	7300	7308	7316	1 2 2 3	4	5 6 6 7
54	7324	7332	7340	7348	7356	7364	7372	7380	7388	7396	1 2 2 3	4	5 6 6 7
55	7404	7412	7419	7427	7435	7443	7451	7459	7466	7474	1 2 2 3	4	5 5 6 7
56	7482	7490	7497	7505	7513	7520	7528	7536	7543	7551	1 2 2 3	4	5 5 6 7
57	7559	7566	7574	7582	7589	7597	7604	7612	7619	7627	1 2 2 3	4	5 5 6 7
58	7634	7642	7649	7657	7664	7672	7679	7686	7694	7701	1 1 2 3	4	4 5 6 7
59	7709	7716	7723	7731	7738	7745	7752	7760	7767	7774	1 1 2 3	4	4 5 6 7
60	7782	7789	7796	7803	7810	7818	7825	7832	7839	7846	1 1 2 3	4	4 5 6 6
61	7853	7860	7868	7875	7882	7889	7896	7903	7910	7917	1 1 2 3	4	4 5 6 6
62	7924	7931	7938	7945	7952	7959	7966	7973	7980	7987	1 1 2 3	3	4 5 6 6
63	7993	8000	8007	8014	8021	8028	8035	8041	8048	8055	1 1 2 3	3	4 5 5 6
64	8062	8069	8075	8082	8089	8096	8102	8109	8116	8122	1 1 2 3	3	4 5 5 6
65	8129	8136	8142	8149	8156	8162	8169	8176	8182	8189	1 1 2 3	3	4 5 5 6
66	8195	8202	8209	8215	8222	8228	8235	8241	8248	8254	1 1 2 3	3	4 5 5 6
67	8261	8267	8274	8280	8287	8293	8299	8306	8312	8319	1 1 2 3	3	4 5 5 6
68	8325	8331	8338	8344	8351	8357	8363	8370	8376	8382	1 1 2 3	3	4 4 5 6
69	8388	8395	8401	8407	8414	8420	8426	8432	8439	8445	1 1 2 2	3	4 4 5 6
70	8451	8457	8463	8470	8476	8482	8488	8494	8500	8506	1 1 2 2	3	4 4 5 6
71	8513	8519	8525	8531	8537	8543	8549	8555	8561	8567	1 1 2 2	3	4 4 5 5
72	8573	8579	8585	8591	8597	8603	8609	8615	8621	8627	1 1 2 2	3	4 4 5 5
73	8633	8639	8645	8651	8657	8663	8669	8675	8681	8686	1 1 2 2	3	4 4 5 5
74	8692	8698	8704	8710	8716	8722	8727	8733	8739	8745	1 1 2 2	3	4 4 5 5
75	8751	8756	8762	8768	8774	8779	8785	8791	8797	8802	1 1 2 2	3	3 4 5 5
76	8808	8814	8820	8825	8831	8837	8842	8848	8854	8859	1 1 2 2	3	3 4 5 5
77	8865	8871	8876	8882	8887	8893	8899	8904	8910	8915	1 1 2 2	3	3 4 4 5
78	8921	8927	8932	8938	8943	8949	8954	8960	8965	8971	1 1 2 2	3	3 4 4 5
79	8976	8982	8987	8993	8998	9004	9009	9015	9020	9025	1 1 2 2	3	3 4 4 5
80	9031	9036	9042	9047	9053	9058	9063	9069	9074	9079	1 1 2 2	3	3 4 4 5
81	9085	9090	9096	9101	9106	9112	9117	9122	9128	9133	1 1 2 2	3	3 4 4 5
82	9138	9143	9149	9154	9159	9165	9170	9175	9180	9186	1 1 2 2	3	3 4 4 5
83	9191	9196	9201	9206	9212	9217	9222	9227	9232	9238	1 1 2 2	3	3 4 4 5
84	9243	9248	9253	9258	9263	9269	9274	9279	9284	9289	1 1 2 2	3	3 4 4 5
85	9294	9299	9304	9309	9315	9320	9325	9330	9335	9340	1 1 2 2	3	3 4 4 5
86	9345	9350	9355	9360	9365	9370	9375	9380	9385	9390	1 1 2 2	3	3 4 4 5
87	9395	9400	9405	9410	9415	9420	9425	9430	9435	9440	0 1 1 2	2	3 3 4 4
88	9445	9450	9455	9460	9465	9469	9474	9479	9484	9489	0 1 1 2	2	3 3 4 4
89	9494	9499	9504	9509	9513	9518	9523	9528	9533	9538	0 1 1 2	2	3 3 4 4
90	9542	9547	9552	9557	9562	9566	9571	9576	9581	9586	0 1 1 2	2	3 3 4 4
91	9590	9595	9600	9605	9609	9614	9619	9624	9628	9633	0 1 1 2	2	3 3 4 4
92	9638	9643	9647	9652	9657	9661	9666	9671	9675	9680	0 1 1 2	2	3 3 4 4
93	9685	9689	9694	9699	9703	9708	9713	9717	9722	9727	0 1 1 2	2	3 3 4 4
94	9731	9736	9741	9745	9750	9754	9759	9763	9768	9773	0 1 1 2	2	3 3 4 4
95	9777	9782	9786	9791	9795	9800	9805	9809	9814	9818	0 1 1 2	2	3 3 4 4
96	9823	9827	9832	9836	9841	9845	9850	9854	9859	9863	0 1 1 2	2	3 3 4 4
97	9868	9872	9877	9881	9886	9890	9894	9899	9903	9908	0 1 1 2	2	3 3 4 4
98	9912	9917	9921	9926	9930	9934	9939	9943	9948	9952	0 1 1 2	2	3 3 4 4
99	9956	9961	9965	9969	9974	9978	9983	9987	9991	9996	0 1 1 2	2	3 3 3 4

	0	1	2	3	4	5	6	7	8	9	1	2	3	4	5	6	7	8	9	
·00	1000	1002	1005	1007	1009	1012	1014	1016	1019	1021	0	0	1	1	1	1	2	2	2	2
·01	1023	1026	1028	1030	1033	1035	1038	1040	1042	1045	0	0	1	1	1	1	1	2	2	2
·02	1047	1050	1052	1054	1057	1059	1062	1064	1067	1069	0	0	1	1	1	1	1	1	2	2
·03	1072	1074	1076	1079	1081	1084	1086	1089	1091	1094	0	0	1	1	1	1	1	1	2	2
·04	1096	1099	1102	1104	1107	1109	1112	1114	1117	1119	0	1	1	1	1	1	1	1	2	2
·05	1122	1125	1127	1130	1132	1135	1138	1140	1143	1146	0	1	1	1	1	1	1	1	2	2
·06	1148	1151	1153	1156	1159	1161	1164	1167	1169	1172	0	1	1	1	1	1	1	1	2	2
·07	1175	1178	1180	1183	1186	1189	1191	1194	1197	1199	0	1	1	1	1	1	1	1	2	2
·08	1202	1205	1208	1211	1213	1216	1219	1222	1225	1227	0	1	1	1	1	1	1	1	2	2
·09	1230	1233	1236	1239	1242	1245	1247	1250	1253	1256	0	1	1	1	1	1	1	1	2	2
·10	1259	1262	1265	1268	1271	1274	1276	1279	1282	1285	0	1	1	1	1	1	1	1	2	2
·11	1288	1291	1294	1297	1300	1303	1306	1309	1312	1315	0	1	1	1	1	1	1	1	2	2
·12	1318	1321	1324	1327	1330	1334	1337	1340	1343	1346	0	1	1	1	1	1	1	1	2	2
·13	1349	1352	1355	1358	1361	1365	1368	1371	1374	1377	0	1	1	1	1	1	1	1	2	2
·14	1380	1384	1387	1390	1393	1396	1400	1403	1406	1409	0	1	1	1	1	1	1	1	2	2
·15	1413	1416	1419	1422	1426	1429	1432	1435	1439	1442	0	1	1	1	1	1	1	1	2	2
·16	1445	1449	1452	1455	1459	1462	1466	1469	1472	1476	0	1	1	1	1	1	1	1	2	2
·17	1479	1483	1486	1489	1493	1496	1500	1503	1507	1510	0	1	1	1	1	1	1	1	2	2
·18	1514	1517	1521	1524	1528	1531	1535	1538	1542	1545	0	1	1	1	1	1	1	1	2	2
·19	1549	1552	1556	1560	1563	1567	1570	1574	1578	1581	0	1	1	1	1	1	1	1	2	2
·20	1585	1589	1592	1596	1600	1603	1607	1611	1614	1618	0	1	1	1	1	1	1	1	2	2
·21	1622	1626	1629	1633	1637	1641	1644	1648	1652	1656	0	1	1	1	1	1	1	1	2	2
·22	1660	1663	1667	1671	1675	1679	1683	1687	1690	1694	0	1	1	1	1	1	1	1	2	2
·23	1698	1702	1706	1710	1714	1718	1722	1726	1730	1734	0	1	1	1	1	1	1	1	2	2
·24	1738	1742	1746	1750	1754	1758	1762	1766	1770	1774	0	1	1	1	1	1	1	1	2	2
·25	1778	1782	1786	1791	1795	1799	1803	1807	1811	1816	0	1	1	1	1	1	1	1	2	2
·26	1820	1824	1828	1832	1837	1841	1845	1849	1854	1858	0	1	1	1	1	1	1	1	2	2
·27	1862	1866	1871	1875	1879	1884	1888	1892	1897	1901	0	1	1	1	1	1	1	1	2	2
·28	1905	1910	1914	1919	1923	1928	1932	1936	1941	1945	0	1	1	1	1	1	1	1	2	2
·29	1950	1954	1959	1963	1968	1972	1977	1982	1986	1991	0	1	1	1	1	1	1	1	2	2
·30	1995	2000	2004	2009	2014	2018	2023	2028	2032	2037	0	1	1	1	1	1	1	1	2	2
·31	2042	2046	2051	2056	2061	2065	2070	2075	2080	2084	0	1	1	1	1	1	1	1	2	2
·32	2089	2094	2099	2104	2109	2113	2118	2123	2128	2133	0	1	1	1	1	1	1	1	2	2
·33	2138	2143	2148	2153	2158	2163	2168	2173	2178	2183	0	1	1	1	1	1	1	1	2	2
·34	2188	2193	2198	2203	2208	2213	2218	2223	2228	2234	1	1	2	2	2	3	3	4	4	5
·35	2239	2244	2249	2254	2259	2265	2270	2275	2280	2286	1	1	2	2	2	3	3	4	4	5
·36	2291	2296	2301	2307	2312	2317	2323	2328	2333	2339	1	1	2	2	2	3	3	4	4	5
·37	2344	2350	2355	2360	2366	2371	2377	2382	2388	2393	1	1	2	2	2	3	3	4	4	5
·38	2399	2404	2410	2415	2421	2427	2432	2438	2443	2449	1	1	2	2	2	3	3	4	4	5
·39	2455	2460	2466	2472	2477	2483	2489	2495	2500	2506	1	1	2	2	2	3	3	4	4	5
·40	2512	2518	2523	2529	2535	2541	2547	2553	2559	2564	1	1	2	2	2	3	3	4	4	5
·41	2570	2576	2582	2588	2594	2600	2606	2612	2618	2624	1	1	2	2	2	3	3	4	4	5
·42	2630	2636	2642	2649	2655	2661	2667	2673	2679	2685	1	1	2	2	2	3	3	4	4	5
·43	2692	2698	2704	2710	2716	2723	2729	2735	2742	2748	1	1	2	2	2	3	3	4	4	5
·44	2754	2761	2767	2773	2780	2786	2793	2799	2805	2812	1	1	2	2	2	3	3	4	4	5
·45	2818	2825	2831	2838	2844	2851	2858	2864	2871	2877	1	1	2	2	2	3	3	4	4	5
·46	2884	2891	2897	2904	2911	2917	2924	2931	2938	2944	1	1	2	2	2	3	3	4	4	5
·47	2951	2958	2965	2972	2979	2985	2992	2999	3006	3013	1	1	2	2	2	3	3	4	4	5
·48	3020	3027	3034	3041	3048	3055	3062	3069	3076	3083	1	1	2	2	2	3	3	4	4	5
·49	3090	3097	3105	3112	3119	3126	3133	3141	3148	3155	1	1	2	2	2	3	3	4	4	5

ANTILOGARITHMS

	0	1	2	3	4	5	6	7	8	9	1	2	3	4	5	6	7	8	9	
·50	3162	3170	3177	3184	3192	3199	3206	3214	3221	3228	1	1	2	3	4	4	4	5	6	7
·51	3236	3243	3251	3258	3266	3273	3281	3289	3296	3304	1	2	2	3	4	4	5	5	6	7
·52	3311	3319	3327	3334	3342	3350	3357	3365	3373	3381	1	2	2	3	4	4	5	5	6	7
·53	3388	3396	3404	3412	3420	3428	3436	3443	3451	3459	1	2	2	3	4	4	5	6	6	7
·54	3467	3475	3483	3491	3499	3508	3516	3524	3532	3540	1	2	2	3	4	4	5	6	6	7
·55	3548	3556	3565	3573	3581	3589	3597	3606	3614	3622	1	2	2	3	4	4	5	6	7	7
·56	3631	3639	3648	3656	3664	3673	3681	3690	3698	3707	1	2	3	3	4	4	5	6	7	8
·57	3715	3724	3733	3741	3750	3758	3767	3776	3784	3793	1	2	3	3	4	4	5	6	7	8
·58	3802	3811	3819	3828	3837	3846	3855	3864	3873	3882	1	2	3	4	4	4	5	6	7	8
·59	3890	3899	3908	3917	3926	3936	3945	3954	3963	3972	1	2	3	4	5	5	6	6	7	8
·60	3981	3990	3999	4009	4018	4027	4036	4046	4055	4064	1	2	3	4	5	5	6	6	7	8
·61	4074	4083	4093	4102	4111	4121	4130	4140	4150	4159	1	2	3	4	5	5	6	7	8	9
·62	4169	4178	4188	4198	4207	4217	4227	4236	4246	4256	1	2	3	4	5	6	6	7	8	9
·63	4266	4276	4285	4295	4305	4315	4325	4335	4345	4355	1	2	3	4	5	6	6	7	8	9
·64	4365	4375	4385	4395	4406	4416	4426	4436	4446	4457	1	2	3	4	5	6	6	7	8	9
·65	4467	4477	4487	4498	4508	4519	4529	4539	4550	4560	1	2	3	4	5	6	6	7	8	9
·66	4571	4581	4592	4603	4613	4624	4634	4645	4656	4667	1	2	3	4	5	6	7	8	9	10
·67	4677	4688	4699	4710	4721	4732	4742	4753	4764	4775	1	2	3	4	5	6	7	8	9	10
·68	4786	4797	4808	4819	4831	4842	4853	4864	4875	4887	1	2	3	4	6	6	7	8	9	10
·69	4898	4909	4920	4932	4943	4955	4966	4977	4989	5000	1	2	3	5	6	6	7	8	9	10
·70	5012	5023	5035	5047	5058	5070	5082	5093	5105	5117	1	2	4	5	6	6	7	8	9	11
·71	5129	5140	5152	5164	5176	5188	5200	5212	5224	5236	1	2	4	5	6	6	7	8	10	11
·72	5248	5260	5272	5284	5297	5309	5321	5333	5346	5358	1	2	4	5	6	6	7	9	10	11
·73	5370	5383	5395	5408	5420	5433	5445	5458	5470	5483	1	3	4	5	6	6	8	9	10	11
·74	5495	5508	5521	5534	5546	5559	5572	5585	5598	5610	1	3	4	5	6	6	8	9	10	12
·75	5623	5636	5649	5662	5675	5689	5702	5715	5728	5741	1	3	4	5	7	7	8	9	10	12
·76	5754	5768	5781	5794	5808	5821	5834	5848	5861	5875	1	3	4	5	7	7	8	9	11	12
·77	5888	5902	5916	5929	5943	5957	5970	5984	5998	6012	1	3	4	5	7	7	8	10	11	12
·78	6026	6039	6053	6067	6081	6095	6109	6124	6138	6152	1	3	4	6	7	7	8	10	11	13
·79	6166	6180	6194	6209	6223	6237	6252	6266	6281	6295	1	3	4	6	7	7	9	10	11	13
·80	6310	6324	6339	6353	6368	6383	6397	6412	6427	6442	1	3	4	6	7	7	9	10	12	13
·81	6457	6471	6486	6501	6516	6531	6546	6561	6577	6592	2	3	5	6	8	8	9	11	12	14
·82	6607	6622	6637	6653	6668	6683	6699	6714	6730	6745	2	3	5	6	8	8	9	11	12	14
·83	6761	6776	6792	6808	6823	6839	6855	6871	6887	6902	2	3	5	6	8	8	9	11	13	14
·84	6918	6934	6950	6966	6982	6998	7015	7031	7047	7063	2	3	5	6	8	8	10	11	13	15
·85	7079	7096	7112	7129	7145	7161	7178	7194	7211	7228	2	3	5	7	8	8	10	12	13	15
·86	7244	7261	7278	7295	7311	7328	7345	7362	7379	7396	2	3	5	7	8	8	10	12	13	15
·87	7413	7430	7447	7464	7482	7499	7516	7534	7551	7568	2	3	5	7	9	9	10	12	14	16
·88	7586	7603	7621	7638	7656	7674	7691	7709	7727	7745	2	4	5	7	9	9	11	12	14	16
·89	7762	7780	7798	7816	7834	7852	7870	7889	7907	7925	2	4	5	7	9	9	11	13	14	16
·90	7943	7962	7980	7998	8017	8035	8054	8072	8091	8110	2	4	6	7	9	9	11	13	15	17
·91	8128	8147	8166	8185	8204	8222	8241	8260	8279	8299	2	4	6	8	9	9	11	13	15	17
·92	8318	8337	8356	8375	8395	8414	8433	8453	8472	8492	2	4	6	8	10	10	12	14	15	17
·93	8511	8531	8551	8570	8590	8610	8630	8650	8670	8690	2	4	6	8	10	10	12	14	16	18
·94	8710	8730	8750	8770	8790	8810	8831	8851	8872	8892	2	4	6	8	10	10	12	14	16	18
·95	8913	8933	8954	8974	8995	9016	9036	9057	9078	9099	2	4	6	8	10	10	12	15	17	19
·96	9120	9141	9162	9183	9204	9226	9247	9268	9290	9311	2	4	6	8	11	11	13	15	17	19
·97	9333	9354	9376	9397	9419	9441	9462	9484	9506	9528	2	4	7	9	11	11	13	15	17	20
·98	9550	9572	9594	9616	9638	9661	9683	9705	9727	9750	2	4	7	9	11	11	13	16	18	20
·99	9772	9795	9817	9840	9863	9886	9908	9931	9954	9977	2	5	7	9	11	11	14	16	18	20



INDEX

(The numbers refer to pages.)

A

- Absolute temperature, 2, 28
- Acceleration of piston, 411
 - of connecting rod, 419
- Actual indicator diagram, 103
- Adiabatic expansion and compression, 6, 69, 322
 - equation, 57, 77
 - flow through orifice, 171
- Advantages of compound expansion, 138
- After burning, 283
- Air, compressed, transmission of power by, 215
 - compressors, 219
 - —, efficiency of, 231
 - motors, 226
 - for combustion of 1 pound of fuel, 234, 238
 - — of 1 cubic foot fuel, 233, 236
- Air-engine, Carnot, 24
 - —, Stirling, 30
 - —, Ericsson, 31
 - —, Joule, 33
- Air standard cycle, 277
- Allan's link motion, 403
- Analysis of flue gases, 362
- Angle of advance of eccentric, 371
- Atkinson cycle, 278, 288
- Atmospheric engine, 273

B

- Balancing rotating weights, 436
 - reciprocating weights, 440, 446
 - of locomotives, 442
- Bell-Coleman refrigerating machine, 155
- Bilgram's valve diagram, 382
- Binary vapour engine, 99
- Blade efficiency, 188, 192
- Boiler draught, 246
 - heating surface, efficiency of, 258
- Boulvin's method for $T\phi$ diagram, 120
- Boyle's Law, 2
- Brake horse-power, 341, 356

C

- Calculation of mean specific heat of flue gases, 239
 - of dryness of steam after expansion, 57
- Callendar, Prof. H., 110, 123, 129
- Calorific value of fuels, 242, 249, 361
- Capper, Prof. F., 124
- Carnot's cycle for gas, 24, 26
 - — for steam engine, 70
 - principle, 26
- Centrifugal governors, 452
- Charles's law, 2
- Choice of a refrigerating agent, 168
- Chimney draught, 247
- Clearance and cushioning, 96, 105
- Co-efficient of performance, 153
- Cold-air refrigerating machine, 154
- Combination of indicator diagrams, 150
- Combustion of hydrogen, 233
 - of carbon, 234
 - of sulphur, 234
 - , most efficient rate of, 267
- Compound expansion, advantages of, 138
 - —, indicator diagram, 139, 150
- Compressed air, transmission of power by, 215
 - Compressors, efficiency of, 231
- Condensation, initial, 106
- Conditions for maximum efficiency, 27
- Connecting rod, inertia of, 418
 - —, kinetic energy of, 423
- Connection between p , v , and T for a gas, 2, 8
 - — — p , v , and t for steam, 41
- Constant volume cycle, 275
 - pressure cycle, 279
 - volume lines, 56
- Controlling force, curve of, 468
- Curtis turbine, 196
- Cut-off governing, 143
- Cycle, Carnot's, 24, 26, 70
 - , Rankine, 73-80
 - , Otto, 276, 282
 - , constant volume, 275
 - , — pressure, 279
- Cycles of operation, 24, 272

Cyclic variation in speed, 430
 Cylinder dimensions, 148
 — feed, 114
 — volumes, ratio of, 142
 — walls, temperature of, 107

D

De Laval turbine, 188
 — —, losses in, 205
 Diagram factors, 96, 131
 — of twisting moment, 415
 Derivation of adiabatic equation for steam, 57, 77
 Design of De Laval nozzle, 176
 Diesel engine, 331
 Draught for boiler furnace, 246
 Dryness fraction, measurement of, 49, 112, 357
 — —, from indicator diagram, 114
 Dynamical load on shaft, 435
 Dynamometer rope, 342

E

Effect of pressure on turbines, 208
 — of superheat on turbines, 209
 — of vacuum on turbines, 209
 — of clearance, 96, 105, 226
 — of high gas speed heat transmission, 262
 — of strength of mixture, 283, 337
 — of turbulence, 309
 — of cylinder dimensions, 337
 — of density of charge, 307
 Efficiency of a heat engine, 1, 26
 — of a perfect engine, 24, 70
 — of gas engines, constant specific heat, 277
 — — —, variable specific heat, 324
 — maximum, conditions for, 27
 — of blades, 188, 192
 Engine trials, steam, 354
 — —, gas and oil, 339
 Entropy, 15, 53, 61
 — and total heat, Mollier diagram, 63
 — temperature diagrams, 25, 30, 32, 35, 54, 89, 120
 Equivalent eccentric, 388, 398, 401, 405, 406, 408
 Ericsson's air engine, 31
 Exhaust steam turbine, 212
 Expansion valve, 388
 Explosion at constant volume, 312

F

Feed water, measurement of, 362
 First law of thermodynamics, 1
 Flow of steam through orifices, 171
 — — — nozzles, 175
 Flywheel, function of, 430

Four-stroke cycle, 276, 282
 Forced draught, 247
 Friction, effect of in jet, 178
 — — — governors, 470
 Fuel consumption, 343
 Fuels, calorific value of, 242, 249

G

Gain of entropy due to throttling, 61
 Gases, permanent, laws of, 2
 —, specific heats of, 2, 315
 Gas engine, theory of, Chaps. XIII. and XIV., pp. 271, 312
 — — —, losses in, 302
 — — —, expansion curves, 291, 305
 — — —, Atkinson, 278, 288
 Gaseous fuels, 249
 Generation of steam, 40
 Glaisher's factor, 347, 482
 Governing of gas engines, 289
 — of steam engines, 143
 — of steam turbines, 213
 Governor, Watt, 452
 —, Porter, 454
 —, Proell, 459, 467
 —, Hartnell, 463
 —, Hartung, 467
 —, sensitiveness of, 461
 —, hunting of, 462
 Gooch link motion, 400
 Graphic representation of work done, 24

H

Hackworth's radial valve gear, 404
 Hartnell governor, 463
 Hartung governor, 467
 Heat drop, 176
 — mechanical, equivalent of, 1
 — carried away by flue gases, 238, 240
 — — — by exhaust gases, 348
 — — — into engine, 346
 — account for gas engine, 352
 — — — steam engine, 359
 — — — steam boiler, 365
 — reception, rate of, 10, 321
 — transmission, 257
 — — — through flat plates, 257
 — — — cylinder walls, 306
 — — — condenser tubes, 269
 — — — thick tube, 261
 Heating surface, efficiency of, 258
 Height of chimney, 247
 High gas speeds, 262
 Hornsby oil engine, 335

I

Ignition in gas engines, 287
 — in petrol engines, 336
 Impulse turbines, 188

Indicated horse power, 339, 354
 — weight of steam, 112
 Indicator diagram, 95, 103, 291
 — — —, combination of, 150
 — — —, directions for taking, 339, 341,
 354
 — — —, effect of friction on, 340
 Induced draught, 247
 Inertia of reciprocating parts, 411
 — of connecting rod, 418, 424
 Initial load on piston, 145
 — condensation, 106
 Injectors, types of, 182
 —, theory of, 180
 Inside lap, 370
 Internal combustion engines, 271, 312, 331
 — energy of a gas, 3, 313, 315
 — — of steam, 43

J

Jacket, steam, 127
 Joule's air engine, 33
 — — — reversed, 155
 — equivalent, 1
 Joy's valve gear, 407

K

Kelvin, statement of second law, 29
 — warming machine, 157
 Kinetic energy of connecting rod, 423
 Klein's construction, 413

L

Lap in valves, 370
 Latent heat of steam, 43
 Laval, de, turbine, 188
 Laws of thermodynamics, 1, 28
 — of permanent gases, 1, 3
 Lead in valves, 371
 Leakage of valves, 122
 Link motion, 397
 — — —, Allan, 403
 — — —, analytical solution of, 402
 — — —, Gooch, 400
 — — —, Stephenson, 398
 Loaded governor, 454, 459, 467
 Locomotive, balancing of, 442
 Losses in gas engines, 303, 339
 — in steam engines, 104, 354
 — in steam turbines, 205

M

Macfarlane Gray's construction, 399
 Marshall's radial valve gear, 406
 Maximum discharge through orifices, 173
 Mean effective pressure, 95, 97
 Mechanical equivalent of heat, 1
 — refrigeration, 153
 Mellanby, Prof. A. L., 111, 129
 Method of drawing $T\phi$ diagram, 119, 120,
 301

Method of twisting moment diagram, 415
 Meyer expansion valve, 388
 Missing quantity, 115
 Mollier diagram, 63, 176

N

Nicolson, Prof. J. T., 110, 123, 129
 Non-expansive engine, 74
 Nozzles, design of, 176

O

Oil engines, 331
 Otto cycle, 276, 282
 Outside lap, 370
 Oval valve diagram, 381

P

Parsons steam turbine, 197
 Permanent gases, laws of, 1, 2, 3
 Petrol engines, 336
 Piston displacement curve, 372
 Porter governor, 454
 Pressure, volume and temperature relations
 in a gas, 2, 8
 — — — in steam, 41
 Primary balancing, 440
 Producer gas, theory, 251
 Proell governor, 459, 467

R

Radial valve gear, Hackworth, 404
 — — —, Marshal, 406
 — — —, Joy, 407
 Rankine cycle, 73, 75-80
 Rankine's statement of the second law, 28
 Rate of combustion, most efficient, 267
 — of heat reception, 10, 321
 Rateau steam turbine, 195
 Ratio of cylinder volumes, 142
 — of expansion, most economical, 126
 Reaction steam turbines, 188
 Receiver engine, 140
 Rectangular valve diagram, 375
 Refrigerating machines, 153-169
 — — —, co-efficient of performance in,
 153
 — — —, Bell-Coleman, 155
 — — —, vapour compression, 158
 — agent, choice of, 168
 Regenerative steam engine, 89
 Relation between C_p and C_v of a gas, 3
 — — — p , v and T of a gas, 2, 8
 — — — p , v and t of steam, 41
 Reuleaux valve diagram, 378
 Reynold's law of heat transmission, 262,
 265

S

- Saturated steam, total heat of, 43
 ———, internal energy of, 43
 ———, specific volume of, 41, 44
 ———, table of properties of, 480
 Saturation curve on p v diagram, 112
 Scavenging in gas engines, 285
 Second law of thermodynamics, 28
 Secondary balancing, 446
 Single stage air compressor, 219
 ——— motor, 227
 Slide valves, 370
 Specific heats of gases, 3, 317
 Steam, formation of, 40
 ———, saturated, 43
 ———, superheated, 45
 ———, table of properties of, 480
 ——— engine, Carnot's cycle for, 70
 ———, Rankine cycle for, 73
 ———, dry saturated during expansion,
 82
 ———, regenerative, 89
 ———, expansion curve, 94
 ——— jacket, 82, 127
 ——— turbines, 186
 ——— consumption, 135, 357
 ——— engine trials, 354
 ——— boiler trial, 360
 Stephenson's link motion, 398
 Stirling's air engine, 30
 Superheated steam, 45

T

- Temperature, absolute, 2, 28
 Temperature-entropy diagram for steam,
 54, 58
 ——— from p v diagram, 119, 301
 ——— for gas engine, 299
 Temperature range of cylinder walls, 107
 Thermodynamics, laws of, 1, 28
 Throttling calorimeter, 50, 357
 ——— of steam, 46
 Total heat in pressure diagram, 65
 Transmission of power by compressed air,
 215
 ——— of heat, 257
 Trials of steam engines, 354
 ——— boilers, 360
 ——— of internal combustion engines, 339
 Turbines, steam, 186
 ———, impulse, 188
 ———, reaction, 188
 ———, single-stage, 188
 ———, multi-stage, 194

- Turbines, Curtis, 196
 ———, De Laval, 188
 ———, Parsons, 197
 ———, Rateau, 195
 ———, Zoelly, 195
 ———, losses in, 205
 ———, effect of pressure on efficiency of, 208
 ———, ——— of superheat efficiency of, 209
 ———, ——— of vacuum efficiency of, 209
 ———, exhaust steam, 212
 ———, governing of, 213
 Twisting moment, 410
 ——— diagram, method of drawing,
 415

U

- Unwin, Prof. W. C., 96

V

- Valve diagram, rectangular, 375
 ———, Reuleaux, 378
 ———, Zeuner, 379
 ———, oval, 381
 ———, Bilgram, 382
 ———, choice of a, 383
 ——— gear, Joy's, 407
 ———, analytical solution of, 386, 394
 ——— leakage, 122
 ——— displacement, components of, 396
 ———, slide, 370
 Vapour compression refrigerating machine,
 158
 Variable specific heat theory, 321

W

- Warming machine, 157
 Watt governor, 452
 Wet steam, 44
 Willan's law, 135
 Wire drawing, 46, 50, 104
 Woolf engine, 139
 Work done by expanding gas, 4, 5
 ——— during adiabatic expansion of
 steam, 69

Y

- Yarrow-Schlick-Tweedy system of balanc-
 ing, 440

Z

- Zeuner valve diagram, 379
 Zoelly turbine, 195

THE END



UNIVERSITY OF CALIFORNIA LIBRARY

This book is DUE on the last date stamped below.

Fine schedule: 25 cents on first day overdue
50 cents on fourth day overdue
One dollar on seventh day overdue.

ENGINEERING LIBRARY

APR 3 1948

MAY 20 1954

JUN 4 1948

OCT 31 1948

JUN 7 - 1954

NOV 12 1948

NOV 26 1948

DEC 28 1948

JAN 3 1949

APR 25 1950 ✓

DEC 5 1950

APR 17 1951 ✓

DEC 23 1953

969388

TJ265
I6
cop. 2

Engineering
Library

THE UNIVERSITY OF CALIFORNIA LIBRARY

Library open

Dec 20-23

Dec 27-31

8-5 PM

